

The logo consists of a red square containing a white icon of a water tap, followed by the word "PLASSON" in white, uppercase, sans-serif font.

PLASSON®

Catalogue

2018



Plasson's innovative products revolutionized the way of connecting polyethylene pipes in the 1960's. We started with fittings for agricultural irrigation and later developed solutions for urban water distribution.

Nowadays, water delivery systems in many of the world's great cities owe their excellence to Plasson's innovative research and development.

Plasson ensures superior designs and products, the widest range of fittings and adaptors and a genuine commitment to quality, delivery and service.

Plasson continues to strive for the future environment. By using Plasson products, you help us to invest in our vision of a world where clean, pure water will be everyone's birthright.

En los años sesenta Plasson revolucionó la forma de conectar tubos de polietileno. En el principio fueron conectores para uso agrícola a partir de los cuales se desarrollaron, más tarde, productos para distribución de agua en sistemas municipales.

Hoy en día, algunas de las más grandes ciudades del mundo, deben la excelencia de sus sistemas de suministro de aguas a la investigación y desarrollo de Plasson.

Plasson no ha ahorrado esfuerzos para desarrollar, mediante excelente diseño, empleando los mejores materiales y con un total compromiso de calidad y servicio, la más amplia línea de conectores y adaptadores.

Nuestro compromiso con el medio ambiente es permanente. Comprando productos Plasson, usted está ayudándonos a seguir invirtiendo en nuestra visión de un mundo donde agua limpia y pura es un derecho natural de todos.

Content

Mechanical Fittings	4 - 93
ElectroFusion Fittings	94 - 179
Series 1 Fittings	180 - 209
Silver Line Fittings	210 - 227





 **PLASSON®**

MECHANICAL FITTINGS

Content

MECHANICAL FITTINGS

Compression Fittings for PE pipe	14 - 41
Conversion & Adaptor Sets from PE to Copper / UPVC / PP / Lead / Galvanised Pipe	42 - 49
Pipe Conversion Chart	50
Accessories for Compression Fittings	58 - 57
Fittings for 160mm PE Pipe	37 - 60
Saddles	61 - 66
BSP Threaded Fittings	67 - 72
Valves	73 - 80
Technical Specifications	81 - 85
Installation Instructions for Compression Fittings	86 - 87
Installation Instructions for Pipe Adaptors Conversion Sets	88 - 90
Installation Instructions for Plass4 and Copper Pipe Adaptor (Universal Adaptor)	91 - 92

MECHANICAL FITTING

Accesorios de presion para tubos de PE	14 - 41
Juegos de conversi3n y adaptadores de PE a Cobre / PVC r3gido/ PP / Plomo / Tubos galvanizados	42 - 49
Gr3fico de conversiones para tuberias	50
Recambios y Accesorios	51 - 57
Accesorios para tuberias de PE 160mm	58 - 60
Collarines	61 - 66
Accesorios roscados (BSP)	67 - 72
V3lvulas	73 - 80
Detalles t3cnicos	81 - 85
Instrucciones de montaje (para accesorios de presion)	86 - 87
Instrucciones de montaje (para adaptadores de tubos) Juegos de conversi3n	88 - 90
Instrucciones de montaje de Plass4 & tubo de cobre y adaptador Universal	91 - 92

Compression Fittings

07010 / 87010

Page 14 | Coupling
Enlace recto



07610 / 87610

Page 15 | Repair Coupling
Enlace recto de reparación



07110 / 87110

Page 16 | Reducing Coupling
Enlace Recto Reductor



07020 / 87020

Page 17 | Male Adaptor
Enlace mixto rosca macho



07720

Page 18 | Male Integral Brass Thread
Enlace mixto rosca macho de latón



07030 / 87030

Page 19 | Female Adaptor
Enlace mixto rosca hembra



0703GO

Page 20 | Female Adaptor G
Enlace mixto rosca hembra G



07320 / 87320

Page 20 | Shouldered Adaptor
Adaptador minero



07120 / 87120

Page 21 | End Plug
Tapón final



07050 / 87050

Page 22 | 90° Elbow
Codo de 90°



07510

Page 22 | 90° Reducing Elbow
Codo de 90° reductor



07850 / 87850

Page 23 | 90° Elbow with Threaded Male Offtake
Codo de 90° compresión rosca macho



07770

Page 24 | 90° Elbow with Male Integral Brass
Codo de 90° con macho integral de latón



07150 / 87150

Page 25 | 90° Elbow with Threaded Female Offtake
Codo de 90° compresión rosca hembra



07060 / 87060

Page 26 | 45° Elbow
Codo de 45°



07450

Page 26 | 45° Elbow with Threaded Male Offtake
Codo de 45° compresión rosca macho



07350

Page 27 | 90° Elbow Adaptor
Codo espiga



07750

Page 27 | Wall Plate Elbow
Codo de aplicación mural



07040 / 87040

Page 28 | 90° Tee
Te de 90°



0704P0

Page 29 | 90° Slip Tee
Te de 90° de reparación



07740

Page 29 | 90° Enlarging Tee
Te de 90° alargado



07340 / 87340

Page 30 | 90° Reducing Tee
Te de 90° reductor



07840

Page 31 | 90° Tee with Threaded Male Offtake
Te de 90° compresión rosca macho



0714S0

Page 31 | 90° Reducing Tee with Threaded Female Offtake
Te de 90° reducción compresión rosca hembra



07140 / 87140

Page 32 | 90° Tee with Threaded Female Offtake/Slip Tee
Te de 90° compresión rosca hembra/Te de reparación



0714P0

Page 33 | 90° Tee with Threaded Female Offtake/Slip Tee
Te de 90° compresión rosca hembra/Te de reparación



07810 / 87810

Page 33 | Coupling with Riser
Enlace recto con derivación rosca macho



07640 / 87640

Page 34 | 45° Tee
Te de 45°



07220 / 87220

Page 35 | Compression Flange Adaptor (with metal flange)
Adaptador compresión-brida (con brida de metal)



072306 / 872306

Page 36 | Flange Adaptor (with metal flange)
Adaptador espiga-brida (con brida de metal)



07006

Page 37 | Metal Flange
Brida de metal



07250

Page 38 | Threaded Adaptor
Adaptador compresión rosca macho



07270

Page 39 | Brass Threaded Adaptor
Adaptador rosca de latón



070170

Page 40 | Plass4 (Universal) Coupling
Plass4 Enlace universal



070570

Page 40 | Plass4 (Universal) Elbow
Codo universal - Plass4



07550

Page 41 | Y-fitting with Threaded Male Offtake
Y compresión rosca macho



07540

Page 41 | Cross with Threaded Female Offtake
Cruz compresión rosca hembra



07970

Page 46 | Grip Ring for UPVC and PP Pipe
Casquillo de apriete para tubos de UPVC y PP



Conversion & Adaptor Sets

17610

Page 43 | Universal Slip Repair Coupler



07438

Page 47 | Conversion Set for Copper Pipe
Juego adaptador para tubos de cobre



071209

Page 43 | Plug Adaptor
Tapón ciego



077802

Page 48 | Conversion Set for Lead Pipe
Juego adaptador para tubos de plomo



078908

Page 48 | Converter Rubber Adaptor for Galvanised Pipe
Convertor Adaptador de goma para tubos de acero galvanizado



07950

Page 44 | Pipe Liner for PE SDR 11 Pipe
Refuerzo de tubos



078907

Page 49 | Conversion Set Adaptor for Galvanised Pipe
Juego convertor de compresion para tubos de acero galvanizado



07896

Page 44 | Adaptor for Copper and Imperial UPVC
Adaptador universal para tubos de cobre y UPVC imperial



Accessories

07930 / 87930

Page 45 | Reducing Set
Juego reductor



07004 / 87004

Page 51 | Nut
Racor



07940

Page 46 | Modular Adaptor
Adaptador modular



07002

Page 52-54 | O - Ring / Seal
Junta tórica / sello



0701C0

Page 46 | Copper Pipe Adaptor
Adaptador tudo de cobre



07003

Page 54-55 | Split Ring
Casquillo de apriete



07005

Page 56

Insert
Inserto de PP



18960

Page 57

Chamfer Tool for PE Pipes
Herramienta para biselar



07990

Page 57

Plasson Wrench
Llave Plasson



Fittings for 160mm Pipes

070106

Page 58

Coupling / Repair Coupling
Enlace recto / Enlace recto de reparación



070406

Page 58

90° Tee
Te de 90°



070506

Page 59

90° Elbow
Codo de 90°



072206

Page 59

Compression Flange
Adaptor (with metal flange)
Adaptador compresión-
brida (con brida de metal)



072306

Page 59

Flange Adaptor (with metal
flange)
Adaptador brida-espiga (con
brida de metal)



073206

Page 60

Shouldered Adaptor
Adaptador minero



07006

Page 60

Half Metal Flange
Brida Meta'lica



**Threaded and Compression
Outlet Saddles**

16076

Page 61

Saddle Single Outlet
Collarín simple



16176

Page 62

Saddle Double Outlet
Collarín doble



16005

Page 63

Plated Nut & Bolt for Saddles
Tornillo y tuerca de acero
niquelado para collarin



Tapping Saddles & Valves

18680

Page 64

Mechanical Tapping Valve
Valvula Mecanica con salida
rotatoria Tapper®



16540

Page 65

Tapper® - for PVC & PE Pipes
Collarin con salida rotatoria
Tapper® para tubos de PVC
y de PE



165400012

Page 66 | Tapper® Brass Cutter for PE & PVC Pipe
Cortatubo para tubos de PE y de PVC



16532

Page 66 | Saddle Seal for Tapper® (EPDM)
Sello de collarín Tapper® (EPDM)



16007

Page 66 | Plated Nut & Bolt for Saddles
Tornillo y tuerca de acero niquelado para collarin



BSP Threaded Fittings

050107

Page 67 | Threaded Socket
Manguito rosca hembra x hembra



050207

Page 67 | Threaded Reducing Bushing
Manguito reductor hembra x macho



050407

Page 68 | 90° Threaded Tee
Te de 90° rosca hembra



050507

Page 68 | 90° Threaded Elbow
Codo de 90° rosca hembra



051507

Page 69 | 90° Threaded Elbow Male x Female
Codo roscado-macho x hembra



050605

Page 69 | Threaded Reducing Nipple
Machón doble reductor



050607

Page 70 | Threaded Nipple
Machón doble



050707

Page 70 | Threaded Cap
Tapón rosca hembra



051107

Page 71 | Threaded Reducing Socket
Manguito reductor rosca hembra - hembra



051607

Page 71 | Threaded Riser
Espiga roscada



051707

Page 72 | Threaded Plug
Tapón rosca macho



Valves

03703

Page 74 | Ball Valve
Válvula esférica



03405

Page 74 | Threaded Stoptap
Válvula de línea rosca hembra



03407

Page 75

Compression Stoptap
Válvula de línea compresión



03048

Page 75

Angle Seat Valve Threaded x
Compression
Válvula de asiento angular -
compresión - rosca



03047

Page 76

Angle Seat Valve (seal NBR),
Threaded Inlet & Outlet
Válvula de asiento angular
(sello NBR), roscas macho



03049

Page 76

Angle Seat Valve (seal FPM),
Threaded Inlet & Outlet
Válvula de asiento angular
(sello FPM), roscas macho



03046

Page 77

Angle Seat Valve
Compression Inlet & Outlet
Válvula de asiento angular
compresión



03067

Page 77

Check Valve (seal EPDM),
Threaded Inlet & Outlet
Válvula antirretorno (Juntas
EPDM), roscas macho



03039

Page 78

Quick Coupling Valve
Válvula de acople rápido



03139

Page 78

Key for Quick Coupling
Valve 3039
Conexión de acople rápido



03226 / 03227

Page 78

Check Valve Insert
Valvula de control



3589

Page 79

BSPT Record for Water
Meter
Tubo y tuerca BSPT



03510

Page 79

Water Meter Manifold
Soporte para control de flujo
de agua



Quarter Turn Valves

03010

Page 80

Male Threaded X
Compression
Rosca Macho-/Compresion



03012

Page 80

Male Threaded X Female
Threaded
Rosca Macho-/Rosca
Hembra



03017

Page 80

Compression X
Compression
Compression



ISRAEL



POLAND



FRANCE



AUSTRIA



AUSTRIA



AUSTRALIA



ITALY



SWITZERLAND



NETHERLANDS



NETHERLANDS



GERMANY



GERMANY



RUSSIA



RUSSIA

Coupling

07010

Enlace recto

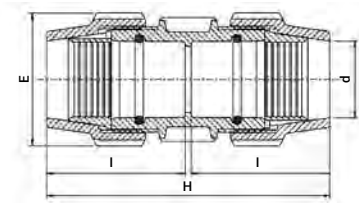

Product Code	Size d x d	E	H	I	UB	UC	W
070106016	16 x 16	39	105	50	10	400	52
070100020	20 x 20	48	122	59	10	200	93
070100025	25 x 25	54	126	61	10	180	116
070100032	32 x 32	64	145	71	5	100	181
070100040	40 x 40	82	177	87	—	75	310
070100050	50 x 50	96	201	98	—	45	455
070100063	63 x 63	113	230	113	—	30	741
070100125	125 x 125	212	460	225	—	3	5347

87010

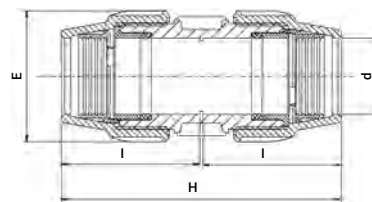

Product Code	Size d x d	E	H	I	UB	UC	W
870100075	75 x 75	132	289	143	—	16	1246
870100090	90 x 90	152	334	164	—	9	1893
870100110	110 x 110	181	398	196	—	5	3321

Repair Coupling

07610

Enlace recto de reparación

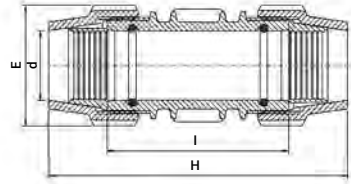

Product Code	Size d x d	E	H	I	UB	UC	W
076100020	20 x 20	48	122	78	10	240	141
076100025	25 x 25	54	136	90	10	150	119
076100032	32 x 32	64	174	120	5	80	202
076100040	40 x 40	82	215	148	—	55	360
076100050	50 x 50	96	244	158	—	30	534
076100063	63 x 63	113	270	170	—	24	826
076100125	125 x 125	212	460	265	—	3	5318

87610

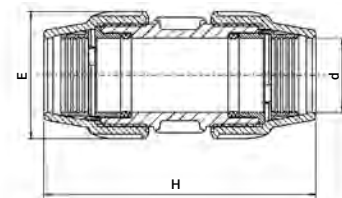

Product Code	Size d x d	E	H	UB	UC	W
876100075	75 x 75	132	289	—	16	1205
876100090	90 x 90	152	334	—	8	1938
876100110	110 x 110	181	398	—	5	3250

Reducing Coupling

07110

Enlace Recto Reductor

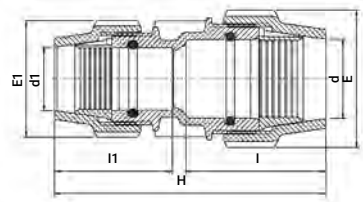

Product Code	Size d x d1	E	E1	H	I	I1	UB	UC	W
071100020016	20 x 16	48	39	111	57	50	10	300	74
071100025016	25 x 16	54	39	113	58	50	10	220	88
071100025020	25 x 20	54	48	119	58	57	10	200	100
071100032020	32 x 20	64	48	140	67	57	5	150	142
071100032025	32 x 25	64	54	133	67	58	5	120	143
071100040025	40 x 25	82	54	156	84	58	—	90	213
071100040032	40 x 32	82	64	156	84	67	—	90	244
071100050025	50 x 25	96	54	176	93	58	—	70	304
071100050032	50 x 32	96	64	175	98	62	—	70	341
071100050040	50 x 40	96	82	184	93	84	—	60	380
071100063025	63 x 25	113	54	193	110	58	—	50	461
071100063032	63 x 32	113	64	197	110	62	—	45	486
071100063040	63 x 40	113	82	208	110	82	—	40	546
071100063050	63 x 50	113	96	214	110	93	—	36	586

87110

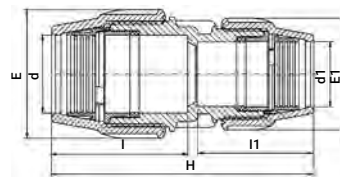

Product Code	Size d x d1	E	E1	H	I	I1	UB	UC	W
871100075050	75 x 50	132	96	250	137	98	—	22	915
871100075063	75 x 63	132	113	257	137	112	—	18	960
871100090063	90 x 63	152	113	291	169	115	—	12	1393
871100090075	90 x 75	152	132	316	169	139	—	10	1659
871100110090	110 x 90	181	152	380	196	161	—	6	2715

Male Adaptor

07020

Enlace mixto rosca macho

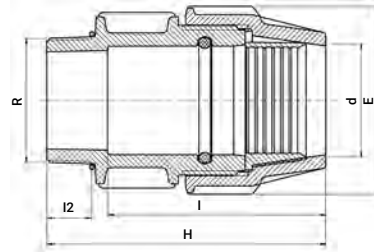

Product Code	Size d x R	E	H	I	I2	UB	UC	W
070206016003	16 x 3/8"	39	76	59	13	10	600	33
070206016005	16 x 1/2"	39	79	59	16	10	500	34
070206016007	16 x 3/4"	39	79	59	17	10	500	35
070200020005	20 x 1/2"	48	92	71	17	10	350	58
070200020007	20 x 3/4"	48	92	71	18	10	350	59
070200020010	20 x 1"	48	86	52	20	10	350	60
070200025005	25 x 1/2"	54	94	72	17	10	250	68
070200025007	25 x 3/4"	54	95	72	18	10	250	73
070200025010	25 x 1"	54	97	72	20	10	250	79
070200032007	32 x 3/4"	64	106	83	18	5	150	113
070200032010	32 x 1"	64	107	83	20	5	150	122
070200032013	32 x 1 1/4"	64	110	83	22	5	150	114
070200032015	32 x 1 1/2"	64	110	83	22	5	140	127
070200040010	40 x 1"	82	118	91	20	—	110	184
070200040013	40 x 1 1/4"	82	117	90	22	—	110	185
070200040015	40 x 1 1/2"	82	117	90	22	—	100	184
070200040020	40 x 2"	82	123	91	26	—	100	208
070200050010	50 x 1"	96	133	106	20	—	70	264
070200050013	50 x 1 1/4"	96	136	106	22	—	70	264
070200050015	50 x 1 1/2"	96	136	109	22	—	70	275
070200050020	50 x 2"	96	140	109	26	—	65	282
070200063013	63 x 1 1/4"	113	154	123	22	—	48	443
070200063015	63 x 1 1/2"	113	154	123	22	—	48	451
070200063020	63 x 2"	113	167	123	26	—	48	461
070200063025	63 x 2 1/2"	113	160	123	29	—	45	459

87020

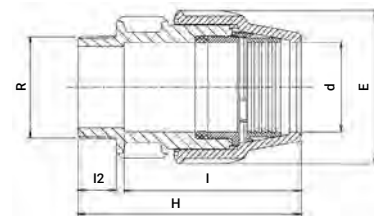

Product Code	Size d x R	E	H	I	I2	UB	UC	W
870200075020	75 x 2"	132	189	156	26	—	28	737
870200075025	75 x 2 1/2"	132	192	156	29	—	28	752
870200075030	75 x 3"	132	196	156	33	—	25	747
870200090020	90 x 2"	152	226	169	26	—	16	1142
870200090025	90 x 2 1/2"	152	229	169	29	—	16	1142
870200090030	90 x 3"	152	232	169	33	—	16	1133
870200090040	90 x 4"	152	238	169	38	—	12	1133
870200110020	110 x 2"	181	263	215	26	—	8	1929
870200110030	110 x 3"	181	259	215	33	—	8	1929
870200110040	110 x 4"	181	267	215	42	—	8	1940

Male Integral Brass Thread

07720

Enlace mixto rosca macho de laton

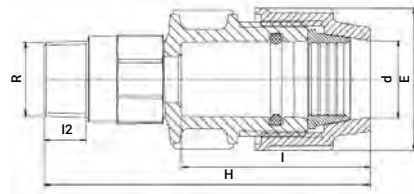

Product Code	Size d x R	E	H	I	I2	UB	UC	W
077200032007	32 x 3/4"	64	139	83	18	1	100	240
077200032010	32 x 1"	64	141	83	20	1	100	276
077200032013	32 x 1 1/4"	64	142	83	22	1	75	300
077200032015	32 x 1 1/2"	64	142	83	22	1	75	330
077200040007	40 x 3/4"	82	149	91	18	1	55	413
077200040010	40 x 1"	82	151	91	20	1	65	413
077200040013	40 x 1 1/4"	82	154	91	22	1	65	428
077200040015	40 x 1 1/2"	82	153	91	22	1	55	428
077200050010	50 x 1"	96	169	106	20	1	45	538
077200050013	50 x 1 1/4"	96	172	106	22	1	45	562
077200050015	50 x 1 1/2"	96	172	106	22	1	45	585
077200063013	63 x 1 1/4"	113	190	123	22	1	30	842
077200063015	63 x 1 1/2"	113	190	123	22	1	30	874
077200063020	63 x 2"	113	194	123	26	1	30	855

Female Adaptor

07030

Enlace mixto rosca hembra

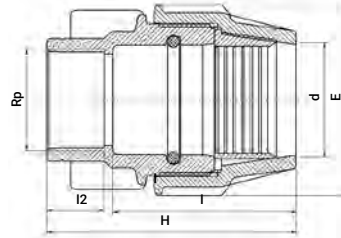

Product Code	Size d x Rp	E	H	I	I2	UB	UC	W
070306016005	16 x 1/2"	39	73	52	19	10	500	36
070306016007	16 x 3/4"	39	75	53	19	10	500	36
070300020005	20 x 1/2"	48	82	60	19	10	350	60
070300020007	20 x 3/4"	48	82	60	19	10	350	58
070300020010	20 x 1"	48	92	57	21	10	300	68
070300025007	25 x 3/4"	54	88	63	21	10	250	83
070300025010	25 x 1"	54	88	63	21	10	250	78
070300032007	32 x 3/4"	64	94	73	19	5	150	106
070300032010	32 x 1"	64	94	69	21	5	150	115
070300032013	32 x 1 1/4"	64	96	67	25	5	140	140
070300040010	40 x 1"	82	112	84	21	—	110	178
070300040013	40 x 1 1/4"	82	114	84	25	—	110	202
070300040015	40 x 1 1/2"	82	114	84	25	—	100	225
070300050013	50 x 1 1/4"	96	123	93	25	—	75	275
070300050015	50 x 1 1/2"	96	123	93	25	—	70	276
070300050020	50 x 2"	96	128	93	30	—	70	293
070300063013	63 x 1 1/4"	113	139	110	25	—	48	417
070300063015	63 x 1 1/2"	113	139	110	25	—	48	435
070300063020	63 x 2"	113	148	110	30	—	48	442

87030

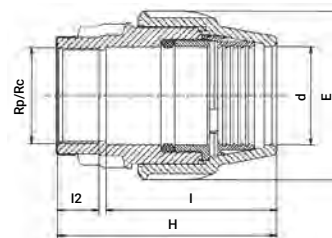

Product Code	Size d x Rp/Rc	E	H	I	I2	UB	UC	W
870300075020	75 x 2"	132	181	137	30	—	27	709
870300075025	75 x 2 1/2"	132	175	137	33	—	27	759
870300090020	90 x 2"	152	212	182	30	—	14	1130
870300090030	90 x 3"	152	222	182	40	—	14	1183
870300090040	90 x 4"	152	242	182	50	—	12	1430
870300110030	110 x 3"	181	263	215	42	—	8	2003
870300110040	110 x 4"	181	273	215	52	—	8	2132

Female Adaptor G

0703G0*

Enlace mixto rosca hembra G

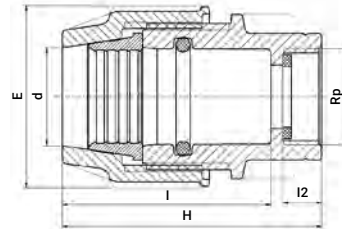

Product Code	Size d x Rp	E	H	I	I2	UB	UC	W
0703G0025007	25 x 3/4"	54	88	63	12	10	250	83
0703G0025010	25 x 1"	54	88	63	14	10	250	78
0703G0032010	32 x 1"	64	89	72	14	5	150	115

* For connecting parallel male thread | * Para conectar rosca macho paralelo

Shouldered Adaptor

07320

Adaptador minero

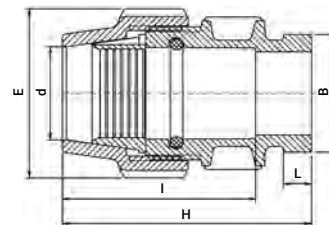

Product Code	Size d x DN (inch)	E	I	L	H	B	UB	UC	W
073200050020	50 x 50 (2")	96	109	16	138	67	—	65	291
073200063020	63 x 50 (2")	113	123	16	156	67	—	45	437

87320

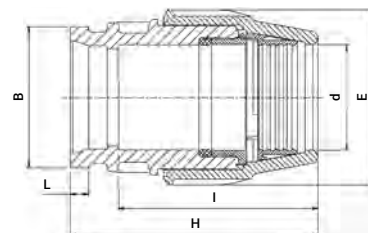

Product Code	Size d x DN (inch)	E	I	L	H	B	UB	UC	W
873200090040	90 x 100 (4")	152	169	16	230	123	—	14	1249
873200110040	110 x 100 (4")	181	215	16	257	123	—	8	1964

End Plug

07120

Tapón final

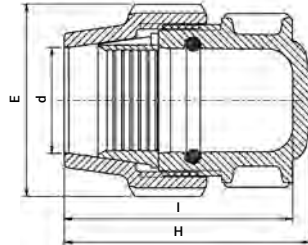

Product Code	Size d	E	I	H	UB	UC	W
071200020	20	48	74	79	10	350	57
071200025	25	54	77	82	10	250	72
071200032	32	64	87	92	5	180	108
071200040	40	82	97	102	—	110	186
071200050	50	96	114	121	—	75	269
071200063	63	113	122	145	—	45	446

87120

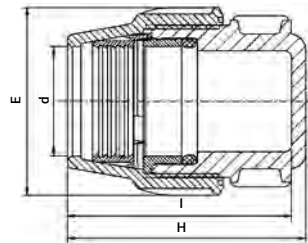

Product Code	Size d	E	I	H	UB	UC	W
871200075	75	132	161	177	—	28	740
871200090	90	152	169	211	—	16	1082
871200110	110	181	221	234	—	10	1920

90° Elbow

07050

Codo de 90°

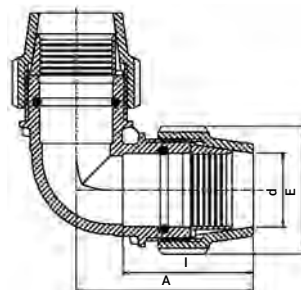

Product Code	Size d x d	E	I	A	UB	UC	W
070506016*	16 x 16	39	50	63	10	350	57
070500020	20 x 20	48	56	73	10	200	95
070500025	25 x 25	54	58	79	10	150	122
070500032	32 x 32	64	67	93	5	100	187
070500040	40 x 40	82	82	108	—	60	341
070500050	50 x 50	96	93	127	—	35	495
070500063	63 x 63	113	110	151	—	24	836

* Only available in black

87050

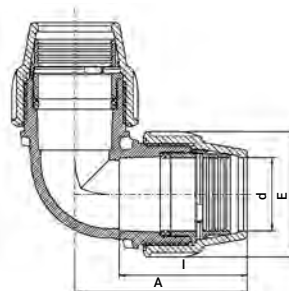

Product Code	Size d x d	E	I	A	UB	UC	W
870500075	75 x 75	132	137	184	—	12	1362
870500090	90 x 90	152	161	216	—	8	2171
870500110	110 x 110	181	196	294	—	4	3997

90° Reducing Elbow

07510

Codo de 90° reductor

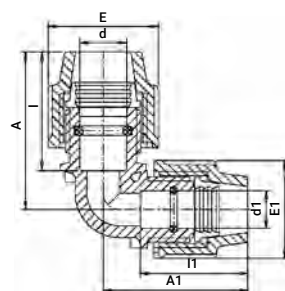

Product Code	Size d x d1	E	E1	I	I1	A	A1	UB	UC	W
075100025020	25 x 20	54	48	58	57	90	75	10	180	114

90° Elbow with Threaded Male Offtake

07850

Codo de 90° compresión rosca macho

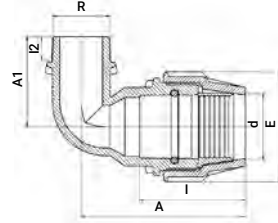

Product Code	Size d x R	E	I	I2	A	A1	UB	UC	W
078500020005	20 x 1/2"	48	57	17	74	41	10	350	55
078500020007	20 x 3/4"	48	57	18	76	43	10	300	64
078500025005	25 x 1/2"	54	58	17	85	47	10	240	70
078500025007	25 x 3/4"	54	58	18	90	48	10	250	79
078500025010	25 x 1"	54	58	20	90	54	10	240	84
078500032007	32 x 3/4"	64	67	18	104	55	5	140	116
078500032010	32 x 1"	64	67	20	104	55	5	140	128
078500032013	32 x 1 1/4"	64	67	22	104	58	5	140	135
078500040010	40 x 1"	82	84	20	124	60	—	90	194
078500040013	40 x 1 1/4"	82	84	22	124	66	—	90	205
078500040015	40 x 1 1/2"	82	84	22	124	66	—	80	218
078500050010	50 x 1"	96	93	20	140	71	—	55	293
078500050013	50 x 1 1/4"	96	93	22	144	74	—	55	335
078500050015	50 x 1 1/2"	96	93	22	144	74	—	55	320
078500050020	50 x 2"	96	93	26	144	76	—	55	373
078500063013	63 x 1 1/4"	113	110	22	168	76	—	35	451
078500063015	63 x 1 1/2"	113	110	22	168	76	—	35	468
078500063020	63 x 2"	113	110	26	170	92	—	35	518

87850

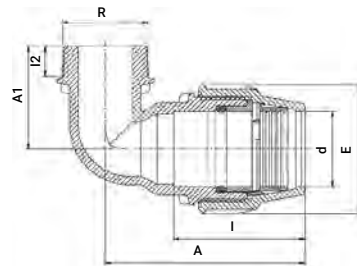

Product Code	Size d x G	E	I	I2	A	A1	UB	UC	W
878500075025	75 x 2 1/2"	132	137	30	207	105	—	18	872
878500075030	75 x 3"	132	137	33	207	110	—	18	934
878500090030	90 x 3"	152	164	33	232	110	—	12	1356
878500110040	110 x 4"	181	196	42	276	140	—	6	2320

90° Elbow with Male Integral Brass

07770

Code de 90° con macho integral de latón

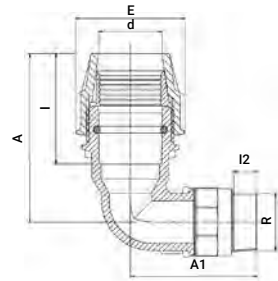

Product Code	Size d x R	E	I	I2	A	A1	UB	UC	W
077700032007	32 x 3/4"	64	67	18	104	79	1	75	270
077700032010	32 x 1"	64	67	20	104	81	1	70	286
077700032013	32 x 1 1/4"	64	67	22	104	82	1	70	343
077700032015	32 x 1 1/2"	64	67	22	104	82	1	70	360
077700040007	40 x 3/4"	82	84	18	124	86	1	55	435
077700040010	40 x 1"	82	84	20	124	88	1	55	435
077700040013	40 x 1 1/4"	82	84	22	124	90	1	55	450
077700040015	40 x 1 1/2"	82	84	22	124	89	1	55	460
077700050010	50 x 1"	96	93	20	144	94	1	40	591
077700050013	50 x 1 1/4"	96	93	22	144	97	1	40	612
077700050015	50 x 1 1/2"	96	93	22	144	97	1	40	612
077700063013	63 x 1 1/4"	113	110	22	168	126	1	27	895
077700063015	63 x 1 1/2"	113	110	22	168	126	1	27	955
077700063020	63 x 2"	113	110	26	170	129	1	27	987

90° Elbow with Threaded Female Offtake

07150

Codo de 90° compresión rosca hembra

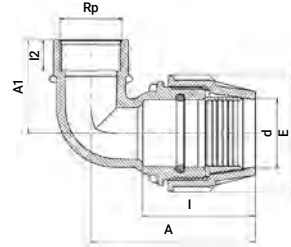

Product Code	Size d x Rp	E	I	I2	A	A1	UB	UC	W
071506016005	16 x 1/2"	39	50	19	66	39	10	500	38
071500020005	20 x 1/2"	48	54	19	78	40	10	350	61
071500020007	20 x 3/4"	48	57	19	78	44	10	300	71
071500025005	25 x 1/2"	54	58	18	81	46	10	250	86
071500025007	25 x 3/4"	54	58	19	81	46	10	250	81
071500025010	25 x 1"	54	58	21	83	50	10	220	90
071500032007	32 x 3/4"	64	67	18	95	54	5	150	143
071500032010	32 x 1"	64	67	21	95	54	5	150	136
071500032013	32 x 1 1/4"	64	67	25	99	60	5	120	167
071500040010	40 x 1"	82	84	21	119	52	—	100	201
071500040013	40 x 1 1/4"	82	84	25	119	62	—	90	232
071500040015	40 x 1 1/2"	82	84	25	119	62	—	80	261
071500040020	40 x 2"	82	84	30	119	75	—	65	293
071500050010	50 x 1"	96	93	21	133	57	—	70	280
071500050013	50 x 1 1/4"	96	93	25	133	67	—	60	312
071500050015	50 x 1 1/2"	96	93	25	135	66	—	60	344
071500050020	50 x 2"	96	93	30	138	85	—	45	387
071500063013	63 x 1 1/4"	113	110	25	162	65	—	35	486
071500063015	63 x 1 1/2"	113	110	25	162	69	—	35	503
071500063020	63 x 2"	113	110	30	160	90	—	35	559

87150

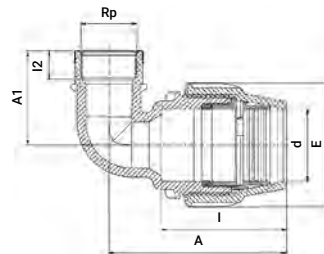

Product Code	Size d x Rp	E	I	I2	A	A1	UB	UC	W
871500075020	75 x 2"	132	137	30	193	100	—	20	860
871500075025	75 x 2 1/2"	132	137	36	196	105	—	18	933
871500075030	75 x 3"	132	137	36	196	105	—	18	982

45° Elbow

07060

Codo de 45°

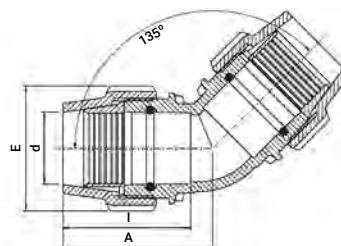

Product Code	Size d x d	E	I	A	UB	UC	W
070600032	32 x 32	64	67	92	5	100	188
070600040	40 x 40	82	84	99	—	60	330
070600050	50 x 50	96	93	110	—	40	474
070600063	63 x 63	113	110	130	—	24	772

87060

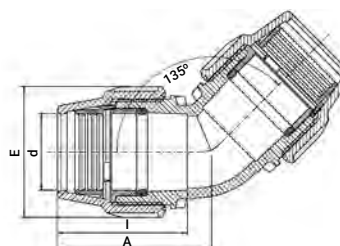

Product Code	Size d x d	E	I	A	UB	UC	W
870600075	75 x 75	132	137	159	—	12	1265
870600090	90 x 90	152	164	194	—	8	2040
870600110	110 x 110	181	196	237	—	4	3550

45° Elbow with Threaded Male Offtake

07450

Codo de 45° compresión rosca macho

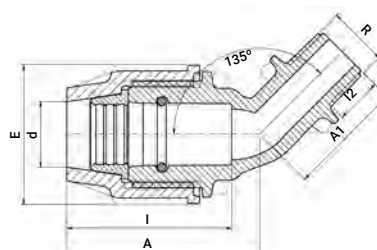

Product Code	Size d x R	E	I	I2	A	A1	UB	UC	W
074500020005	20 x 1/2"	48	57	17	64	40	10	350	54
074500020007	20 x 3/4"	48	57	18	64	41	10	350	55

90° Elbow Adaptor

07350

Codo espiga

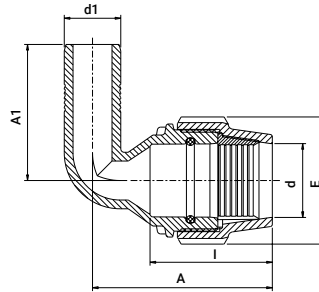

Product Code	Size d x d1	E	I	A	A1	UB	UC	W
073500040040	40 x 40	82	84	118	106	—	80	148
073500040050	40 x 50	82	84	118	120	—	70	275
073500050040	50 x 40	96	93	136	106	—	60	179
073500050050	50 x 50	96	93	136	120	—	55	355
073500063040	63 x 40	113	110	161	106	—	40	450
073500063050	63 x 50	113	110	161	120	—	35	495

Wall Plate Elbow

07750

Codo de aplicación mural

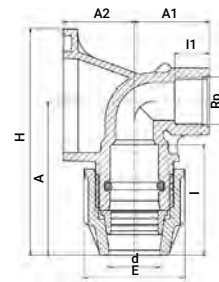

Product Code	Size d x Rp	E	I	I2	A	A1	A2	H	UB	UC	W
077500016005	16 x 1/2"	39	50	18	76	40	38	110	1	150	98
077500020005	20 x 1/2"	48	57	18	78	40	38	110	1	150	92
077500025007	25 x 3/4"	54	58	19	81	40	38	120	1	100	115

90° Tee

07040

Te de 90°

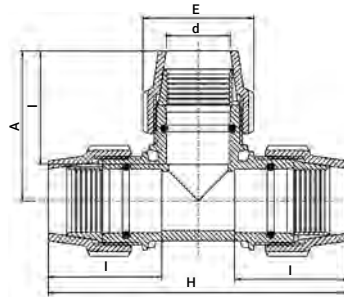

Product Code	Size d x d x d	E	H	I	A	UB	UC	W
070406016	16 x 16 x 16	39	126	50	63	10	220	83
070400020	20 x 20 x 20	48	145	56	73	10	120	141
070400025	25 x 25 x 25	54	156	58	78	5	100	173
070400032	32 x 32 x 32	64	185	67	93	5	60	285
070400040	40 x 40 x 40	82	221	86	111	—	40	498
070400050	50 x 50 x 50	96	252	95	126	—	25	736
070400063	63 x 63 x 63	113	294	110	146	—	16	1213

87040

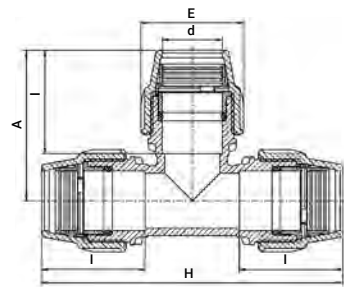

Product Code	Size d x d x d	E	H	I	A	UB	UC	W
870400075	75 x 75 x 75	132	364	137	182	—	8	1947
870400090	90 x 90 x 90	152	438	164	219	—	5	3235
870400110	110 x 110 x 110	181	583	196	294	—	2	5880

90° SlipTee

0704P0

Te de 90° de reparación

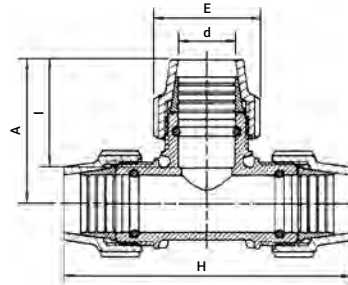

Product Code	Size d x d x d	E	H	I	A	UB	UC	W
0704P0020	20 x 20 x 20	48	145	56	73	10	120	133
0704P0025	25 x 25 x 25	54	156	58	78	5	100	173
0704P0032	32 x 32 x 32	64	185	67	93	5	60	280
0704P0040	40 x 40 x 40	82	221	86	111	—	40	484
0704P0050	50 x 50 x 50	96	252	95	126	—	25	716
0704P0063	63 x 63 x 63	113	294	110	146	—	16	1107

90° Enlarging Tee

07740

Te de alargado

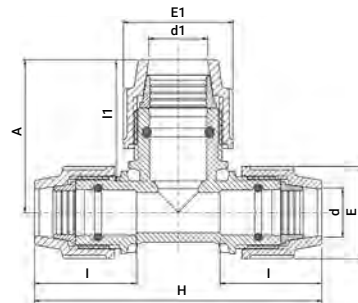

Product Code	Size d x d1 x d	E	E1	H	I	I1	A	UB	UC	W
077400025032	25 x 32 x 25	54	64	156	58	69	87	5	80	220

90° Reducing Tee

07340

Te de 90° reductor

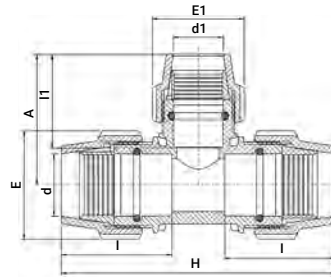

Product Code	Size d x d1 x d	E	E1	H	I	I1	A	UB	UC	W
073400020016	20 x 16 x 20	48	39	137	57	50	70	10	150	125
073400025020	25 x 20 x 25	54	48	150	58	57	74	5	100	166
073400032025	32 x 25 x 32	64	54	173	67	58	83	5	70	254
073400040025	40 x 25 x 40	82	54	205	84	58	84	—	45	412
073400040032	40 x 32 x 40	82	64	207	82	67	97	—	40	428
073400050025	50 x 25 x 50	96	54	228	93	76	105	—	30	542
073400050032	50 x 32 x 50	96	64	230	93	67	117	—	30	587
073400050040	50 x 40 x 50	96	82	236	93	82	114	—	30	643
073400063032	63 x 32 x 63	113	64	268	113	62	118	—	20	892
073400063040	63 x 40 x 63	113	82	268	113	84	139	—	20	961
073400063050	63 x 50 x 63	113	96	275	110	93	132	—	18	1019

87340

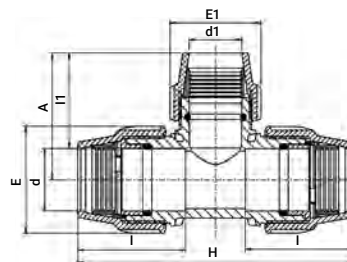

Product Code	Size d x d1 x d	E	E1	H	I	I1	A	UB	UC	W
873400075063	75 x 63 x 75	132	113	364	137	109	153	—	10	1661

90° Tee with Threaded Male Offtake

07840

Te de 90° compresión rosca macho

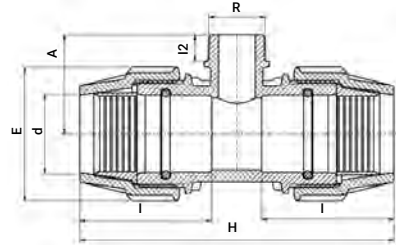

Product Code	Size d x R x d	E	H	I	I2	A	UB	UC	W
078400020005	20 x 1/2" x 20	48	138	56	17	46	10	180	105
078400020007	20 x 3/4" x 20	48	144	56	18	46	10	180	108
078400025005	25 x 1/2" x 25	54	146	58	17	48	5	140	134
078400025007	25 x 3/4" x 25	54	146	58	18	50	5	140	137
078400032010	32 x 1" x 32	64	170	67	20	58	5	80	218
078400040013	40 x 1 1/4" x 40	82	205	84	22	71	—	50	373
078400040015	40 x 1 1/2" x 40	82	205	84	22	71	—	50	376
078400050013	50 x 1 1/4" x 50	96	230	93	22	77	—	36	508
078400050015	50 x 1 1/2" x 50	96	230	93	22	77	—	36	521
078400050020	50 x 2" x 50	96	230	93	26	82	—	36	521
078400063013	63 x 1 1/4" x 63	113	268	113	22	79	—	20	821
078400063015	63 x 1 1/2" x 63	113	268	113	22	83	—	20	828
078400063020	63 x 2" x 63	113	272	110	26	92	—	20	876

90° Reducing Tee with Threaded Female Offtake

0714S0

Te de 90° reducción compresión rosca hembra

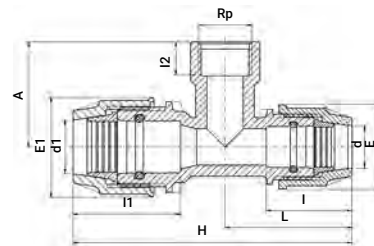

Product Code	Size d x Rp x d	E	E1	H	L	I	I1	I2	A	UB	UC	W
0714S0020016	20 x 3/4" x 16	48	39	132	69	52	50	19	42	10	180	86
0714S0025020	25 x 3/4" x 20	54	48	139	70	53	52	22	42	5	140	145
0714S0032025	32 x 1" x 25	64	54	169	91	67	58	22	58	5	80	176

90° Tee with Threaded Female Offtake

07140

Te de 90° compresión rosca hembra

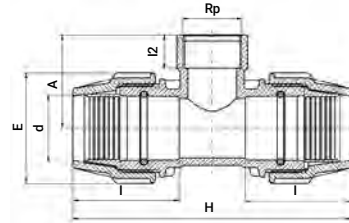

Product Code	Size d x Rp x d	E	H	I	I2	A	UB	UC	W
071406016005	16 x 1/2" x 16	39	122	50	17	42	10	240	66
071406016007	16 x 3/4" x 16	39	122	50	19	41	10	240	65
071400020005	20 x 1/2" x 20	48	144	56	18	42	10	180	104
071400020007	20 x 3/4" x 20	48	144	56	19	45	10	180	110
071400025005	25 x 1/2" x 25	54	151	58	18	45	5	140	131
071400025007	25 x 3/4" x 25	54	151	58	19	48	5	140	140
071400025010	25 x 1" x 25	54	158	58	21	53	5	100	139
071400025013	25 x 1 1/4" x 25	54	158	58	25	64	5	80	194
071400032007	32 x 3/4" x 32	64	177	67	19	51	5	80	210
071400032010	32 x 1" x 32	64	177	67	21	54	5	80	213
071400032013	32 x 1 1/4" x 32	64	182	67	25	65	5	60	253
071400032015	32 x 1 1/2" x 32	64	182	67	25	71	5	60	268
071400040010	40 x 1" x 40	82	203	84	21	61	—	60	348
071400040013	40 x 1 1/4" x 40	82	217	84	24	70	—	55	403
071400040015	40 x 1 1/2" x 40	82	217	84	25	70	—	50	412
071400040020	40 x 2" x 40	82	217	84	30	78	—	45	435
071400050015	50 x 1 1/2" x 50	96	244	93	25	76	—	36	572
071400050020	50 x 2" x 50	96	244	93	30	80	—	30	588
071400063013	63 x 1 1/4" x 63	113	268	113	27	95	—	20	886
071400063015	63 x 1 1/2" x 63	113	268	113	27	95	—	20	898
071400063020	63 x 2" x 63	113	272	110	30	95	—	20	904

87140

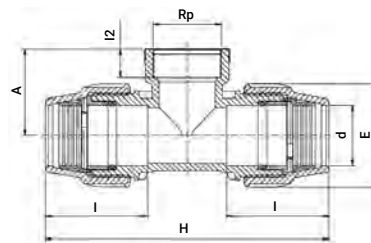

Product Code	Size d x Rp x d	E	H	I	I2	A	UB	UC	W
871400075020	75 x 2" x 75	132	370	137	30	110	—	9	1517
871400075025	75 x 2 1/2" x 75	132	342	134	35	85	—	9	1570
871400075030	75 x 3" x 75	132	370	137	36	110	—	9	1627
871400090030	90 x 3" x 90	152	418	164	41	116	—	7	2351
871400110040	110 x 4" x 110	181	516	200	52	140	—	4	4189

90° Slip Tee with Threaded Female Offtake

0714P0

Te de 90° roscas hembra de reparación

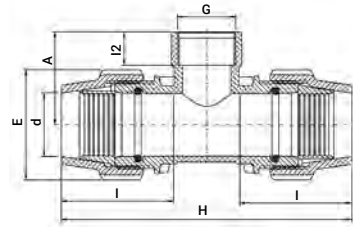

Product Code	Size d x G x d	E	H	I	I2	A	UB	UC	W
0714P0040010	40 x 1" x 40	82	203	84	21	61	—	60	333
0714P0050015	50 x 1 1/2" x 50	96	244	93	25	76	—	36	547
0714P0063013	63 x 1 1/4" x 63	113	268	113	27	95	—	20	860

Coupling with Riser

07810

Enlace recto con derivación rosca macho

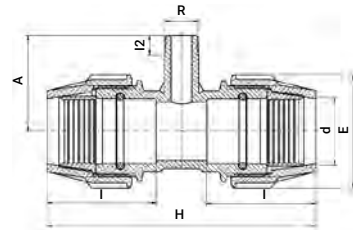

Product Code	Size d x R x d	E	I	I2	H	A	UB	UC	W
078100040007	40 x 3/4" x 40	82	89	18	215	85	5	50	366
078100050007	50 x 3/4" x 50	96	98	18	244	90	5	36	510
078100050010	50 x 1" x 50	96	98	20	244	90	5	36	517
078100063007	63 x 3/4" x 63	113	110	18	270	95	—	24	822
078100063010	63 x 1" x 63	113	110	20	270	95	—	24	820

87810

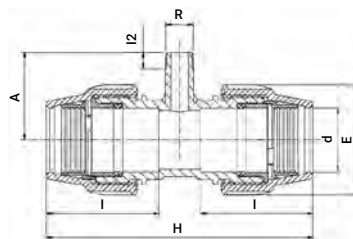

Product Code	Size d x R x d	E	I	I2	H	A	UB	UC	W
878100075007	75 x 3/4" x 75	132	137	18	324	105	—	12	1300
878100075010	75 x 1" x 75	132	137	20	324	105	—	12	1310

45° Tee

07640

Te de 45°

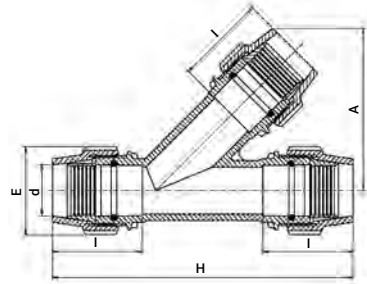

Product Code	Size d x d x d	E	H	I	A	UB	UC	W
076400063	63 x 63 x 63	113	374	110	207	—	10	1428

87640

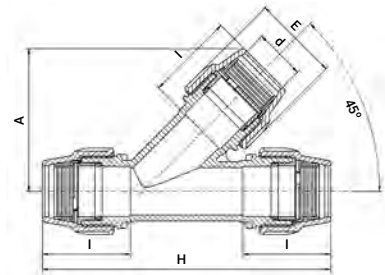

Product Code	Size d x d x d	E	H	I	A	UB	UC	W
876400075	75 x 75 x 75	132	446	137	204	—	6	2500
876400090	90 x 90 x 90	152	519	164	233	—	4	3600
876400110	110 x 110 x 110	181	630	196	284	—	2	6000

Compression Flange Adaptor (with Metal Flange)

07220*

Adaptador compresión-brida (con brida de metal)

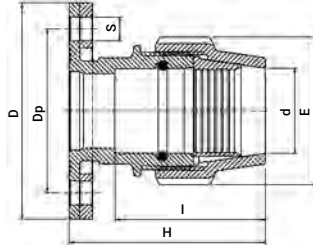

Product Code	Size d x DN (inch)	E	H	I	D	Dp	S	No. of Holes	Metal-Flange Size	UC	W
072200040015	40 x 40 (1 1/2")	82	119	93	150	110	18	4	40 x 40	20	1200
072200050015	50 x 40 (1 1/2")	96	128	93	150	110	18	4	50 x 40	20	1212
072200050020	50 x 50 (2")	96	128	93	165	125	18	4	50 x 50	15	1516
072200063020	63 x 50 (2")	113	145	110	165	125	18	4	63 / 75 x 50	15	1563
072200125050	125 x 125 (5")	212	270	250	250	210	22	8	125 / 160 x 125	4	5534
072200125060	125 x 150 (6")	212	270	250	285	240	22	8	125 / 160 x 150	3	7037

* 072210 - Compression Flange Adaptor without metal flange | * 072210 - Sin brida de metal

87220*

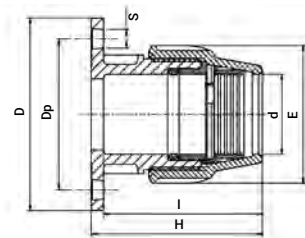

Product Code	Size d x DN (inch)	E	H	I	D	Dp	S	No. of Holes	Metal-Flange Size	UC	W
872200075025	75 x 65 (2 1/2")	132	169	157	185	145	18	4	75 / 90 x 65	12	2200
872200090030	90 x 80 (3")	152	194	182	200	160	18	8	90 / 110 x 80	10	2429
872200090040	90 x 100 (4")	152	194	182	220	180	18	8	90 x 100	8	2980
872200110040	110 x 100 (4")	181	237	224	220	180	18	8	110 x 100	8	3402

* 872210 - Compression flange adaptor without metal flange | * 872210 - Sin brida de metal

Flange Adaptor (with Metal Flange)

072306*

Adaptador espiga-brida (con brida de metal)

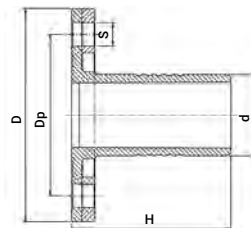

Product Code	Size d x DN (inch)	H	D	Dp	S	No. of Holes	Metal-Flange Size	UC	W
072306050015	50 x 40 (1 1/2")	99	150	110	18	4	50 x 40	20	1064
072306050020	50 x 50 (2")	99	165	125	18	4	50 x 50	20	1094
072306063020	63 x 50 (2")	124	165	125	18	4	63 / 75 x 50	18	1311
072306063025	63 x 65 (2 1/2")	124	185	145	18	4	63 x 65	15	1882

* 072301 - Flange adaptor without metal flange | * 072301 - Sin brida de metal

872306*

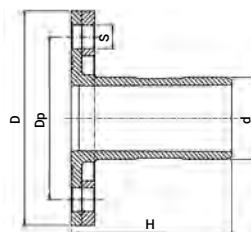

Product Code	Size d x DN (inch)	H	D	Dp	S	No. of Holes	Metal-Flange Size	UC	W
0723060750200A	75 x 50 (2")	142	165	125	18	4	63 / 75 x 50	15	1402
0723060750250A	75 x 65 (2 1/2")	142	185	145	18	4	75 / 90 x 65	15	1568
0723060750300A	75 x 80 (3")	142	200	160	18	8	75 x 80	12	1981
0723060900250A	90 x 65 (2 1/2")	175	185	145	18	4	75 / 90 x 65	12	1754
0723060900300A	90 x 80 (3")	175	200	160	18	8	90 / 110 x 80	12	1858
0723060900400A	90 x 100 (4")	175	220	180	18	8	90 x 100	10	2180
0723061100300A	110 x 80 (3")	210	200	160	18	8	90 / 110 x 80	10	2019
0723061100400A	110 x 100 (4")	210	220	180	18	8	100 x 100	8	2329
0723061100500A	110 x 125 (5")	214	250	210	18	8	110 x 125	6	3987

* 872301 - Flange adaptor without metal flange | * 872301 - Sin brida de metal

Metal Flange

07006

Brida de metal

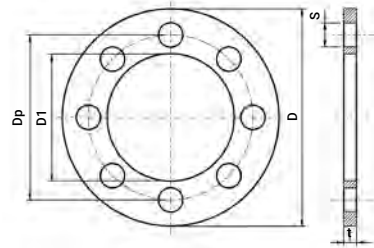

Product Code	Size d x DN (inch)	D	Dp	D1	S	t	Th* (mm)	Th* (inch)	No. of Holes	UC	W
070060050015P	50 x 40 (1 1/2")	150	110	82	18	10	M16	3/4	4	20	844
070060050020P	50 x 50 (2")	165	125	82	18	10	M16	3/4	4	20	1141
070060075020P	63 / 75 x 50 (2")	165	125	96	18	10	M16	3/4	4	20	986
070060063025P	63 x 65 (2 1/2")	185	145	96	18	10	M16	3/4	4	20	1420
070060075025P	75 / 90 x 65 (2 1/2")	185	145	112	18	10	M16	3/4	4	20	1350
070060075030P	75 x 80 (3")	200	160	112	18	10	M16	3/4	8	15	1430
070060090030P	90 / 110 x 80 (3")	200	160	132	18	10	M16	3/4	8	15	1215
070060090040P	90 x 100 (4")	220	180	132	18	10	M16	3/4	8	15	1720
070060110040P	110 x 100 (4")	220	180	151	18	10	M16	3/4	8	15	1416
070060110050P	110 x 125 (5")	250	210	151	18	10	M16	3/4	8	15	2850

* Nominal diameter of bolts | * Diametro nominal del tornillo

Threaded Adaptor

07250*

Adaptador compresión rosca macho

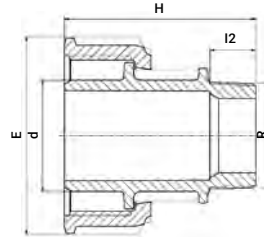

Product Code	Size d x R	E	H	I2	UB	UC	W
072500025005	25 x 1/2"	54	79	17	1	200	36
072500025007	25 x 3/4"	54	80	18	1	200	36
072500032005	32 x 1/2"	64	85	17	1	180	66
072500032007	32 x 3/4"	64	86	18	1	180	65
072500032010	32 x 1"	64	87	20	1	180	68
072500040010	40 x 1"	82	99	20	1	130	108
072500040013	40 x 1 1/4"	82	100	22	1	130	112
072500040015	40 x 1 1/2"	82	100	22	1	130	114
072500050010	50 x 1"	96	102	20	1	80	147
072500050013	50 x 1 1/4"	96	104	24	1	80	154
072500050015	50 x 1 1/2"	96	104	24	1	80	156
072500050020	50 x 2"	96	107	27	1	80	158
072500063010	63 x 1"	113	108	20	1	60	228
072500063013	63 x 1 1/4"	113	111	22	1	60	230
072500063015	63 x 1 1/2"	113	111	22	1	60	230
072500063020	63 x 2"	113	114	26	1	60	258
072500063025	63 x 2 1/2"	113	116	29	1	60	250
072500075015	75 x 1 1/2"	132	128	22	1	30	404
072500075020	75 x 2"	132	132	26	1	30	402
072500075025	75 x 2 1/2"	132	134	29	1	30	412
072500075030	75 x 3"	132	137	33	1	30	430

* Threaded Adaptor Body Cat. No. 078901. Threaded Adaptor Nut - Cat. No. 078940

* Cuerpo del adaptador roscado - Cat. No. 078901. Racor para el adaptador roscado - Cat. No. 078940

Brass Threaded Adaptor

07270

Adaptador rosca de latón

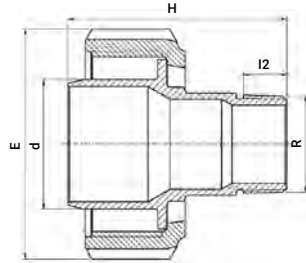

Product Code	Size d x R	I2	H	E	UB	UC	W
072700032010	32 x 1"	19	77	64	1	50	279
072700040010	40 x 1"	19	81	82	1	50	363
072700040013	40 x 1 1/4"	21	90	82	1	50	487
072700050013	50 x 1 1/4"	21	95	96	1	30	523
072700050015	50 x 1 1/2"	21	97	96	1	30	554
072700063013	63 x 1 1/4"	21	105	113	1	20	767
072700063015	63 x 1 1/2"	21	107	113	1	20	762
072700063020	63 x 2"	25	112	113	1	20	985

Plass4 (Universal) Coupling

070170

Plass4 Enlace (universal)

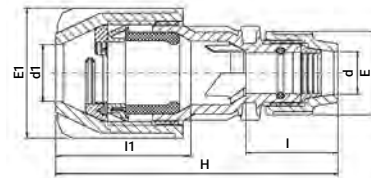

Product Code	Size d x d1	E	E1	I	I1	H	UB	UC	W
070170020027	20 x 20 - 27	48	71	57	85	169	1	80	206
070170025022	25 x 15 - 22	54	64	58	80	165	1	90	183
070170025027	25 x 20 - 27	54	71	58	85	170	1	80	206
070170025035	25 x 27 - 35	54	83	58	90	180	1	60	281
070170032027	32 x 20 - 27	64	71	67	85	180	1	70	240
070170032035	32 x 27 - 35	64	83	67	90	195	1	60	312
070170050050	50 x 35 - 50	96	121	93	125	270	1	20	900

Plass4 (Universal) 90° Elbow

070570

Plass4 - Codo de 90° (universal)

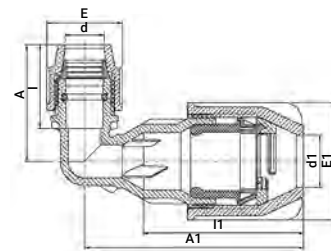

Product Code	Size d x d1	E	E1	I	I1	A	A1	UB	UC	W
070570025022	25 x 15 - 22	54	64	58	105	81	128	1	90	195
070570025027	25 x 20 - 27	54	71	58	105	81	139	1	80	238
070570025035	25 x 27 - 35	54	83	58	112	81	153	1	60	305

Y-Fitting with Threaded Male Offtake

07550

Y compresión rosca macho

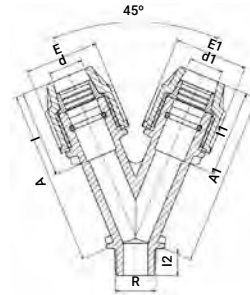

Product Code	Size d x d1 x R	E	E1	I	I1	I2	A	A1	UB	UC	W
075506016007	16 x 16 x 3/4"	39	39	50	50	18	100	100	10	200	75
075500020016	20 x 16 x 3/4"	48	39	57	50	18	108	105	10	180	103
075500020007	20 x 20 x 3/4"	48	48	57	57	18	114	114	10	120	130
075500025007	25 x 25 x 3/4"	54	54	58	58	18	125	125	5	100	154

* In this case diameter should read: d x d x G | * En este caso el diametro debe leido: d x d x G

Cross with Threaded Female Offtake

07540

Cruz compresión rosca hembra

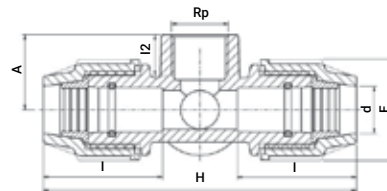

Product Code	Size d x d x d x d x Rp	E	I	I2	H	A	UB	UC	W
075400020007	20 x 20 x 20 x 20 x 3/4"	48	57	21	149	35	5	80	204



UNIVERSAL SLIP REPAIR COUPLING

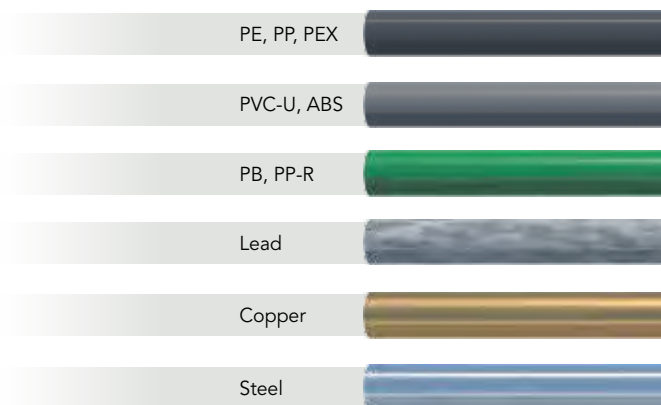

**SLIDE
N'SEAL**
Pull-Out Resistant

PN16	PN16	PN16	PN16	PN16
24-28 _{mm}	31-35 _{mm}	40-43 _{mm}	48-51 _{mm}	60-64 _{mm}
0.94"-1.1"	1.22"-1.37"	1.57"-1.69"	1.89"-2.00"	2.36"-2.52"

- Suits a variety of plastic and metal pipe materials
- Each fitting designed to fit a wide range of diameters
- Zero force pipe insertion – can slide freely back and forth
- Thick o-ring seal – compensates for poor pipe quality
- Long sealing area – can bridge over damaged section or gap between pipes



*For further information regarding dimensions, suitable pipes and assembly instructions please scan the code.

Universal Slip Repair Coupler

NEW!

17610

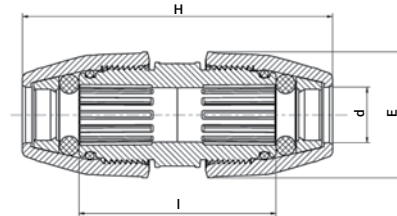

Product Code	Size d	E	H	I	UB	UC	W
176100024028	24-28	66	200	133	—	56	345
176100031035	31-35	76	210	143	—	40	—
176100040043	40-43	89	250	151	—	30	717
176100048051	48-51	101	270	158	—	20	—
176100060064	60-64	120	310	176	—	10	—

Plug Adaptor

071209

Tapón ciego

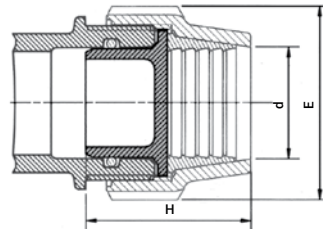

Product Code	Size d	E	H	UB	UC	W
071209020	20	48	47	10	2500	4
071209025	25	54	51	10	1500	7
071209032	32	64	56	10	1000	15
071209040	40	82	66	10	720	24
071209050	50	96	80	10	400	37
071209063	63	113	96	10	200	75

Pipe Liner for PE SDR 11 Pipe

07950

Refuerzo de tubos

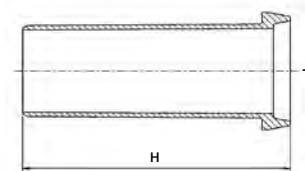

Product Code	Size d	H	UB	UC	W
079500020	20 x 1.9	63	10	2520	5
079500025	25 x 2.3	63	10	1680	10
079500032	32 x 3.0	79	10	920	18
079500040	40 x 3.7	97	10	480	25
079500050	50 x 4.6	106	10	240	55
079500063	63 x 5.8	125	5	110	90

* O.D. of pipe x wall thickness of pipe | * Diametro externo del tubo x espesor del tubo

Adaptor for Copper and Imperial UPVC

07896*

Adaptador para cobre y PVCU

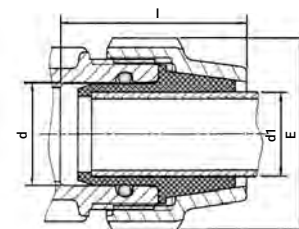

Product Code	Size d x d1	E	I	UB	UC	W
07896015P	20 x 15	48	66	25	1500	15
07896022P	25 x 22	54	64	20	1200	15
07896028P	32 x 28	64	74	20	700	27
07896035P	40 x 35	82	92	10	240	54
07896042P	50 x 42	96	105	10	160	111

* No Pull-Out Resistance | * Sin resistencia a la tracción

Reducing Set

07930

Juego reductor

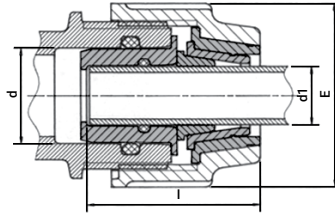

Product Code	Size d x d1	E	I	UB	UC	W
079300025020	25 x 20	54	56	1	300	23
079300032020	32 x 20	64	62	1	300	38
079300032025	32 x 25	64	60	1	250	35
079300040020	40 x 20	82	73	1	180	62
079300040025	40 x 25	82	69	1	180	81
079300040032	40 x 32	82	77	1	200	62
079300050025	50 x 25	96	85	1	120	114
079300050032	50 x 32	96	87	1	120	112
079300050040	50 x 40	96	85	1	120	97
079300063025	63 x 25	113	103	1	80	217
079300063032	63 x 32	113	102	1	80	214
079300063040	63 x 40	113	103	1	80	202
079300063050	63 x 50	113	105	1	80	186
879300075063	75 x 63	132	121	1	70	220
079300110063	110 x 63	181	131	1	24	705

87930

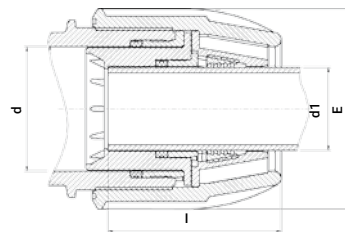

Product Code	Size d x d1	E	I	UB	UC	W
879300075063	75 x 63*	132	121	1	70	220
079300110063	110 x 63	181	131	1	24	705
879300110075	110 x 75	181	145	1	25	655
879300110090	110 x 90	181	154	1	20	671

* Assembled without the inserts

Modular Adaptor

07940

Adaptador modulado

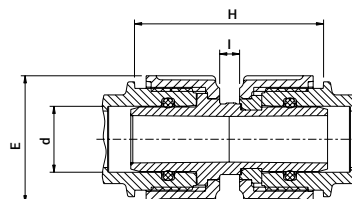

Product Code	Size d	E	H	I	UB	UC	W
079400020	20	48	80	10	—	300	50
079400025	25	54	80	10	—	250	61
079400032	32	64	93	10	—	180	104
079400040	40	82	102	10	—	100	173
079400050	50	93	107	10	5	70	257
079400063	63	113	119	10	5	45	420

Copper Pipe Adaptor

0701C0

Adaptador para tubo de cobre

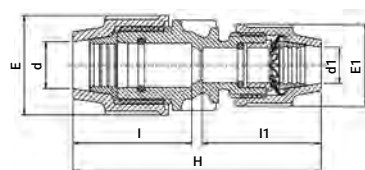

Product Code	Size d (PE) x d1 (Cu)	E	E1	H	I	I1	UB	UC	W
0701C0020005	20 x 15	48	39	115	56	54	—	200	103
0701C0025015	25 x 15	54	39	124	55	54	—	180	86
0701C0025022	25 x 22	54	54	136	60	71	—	150	132
0701C0032028	32 x 28	64	64	150	70	77	—	100	204

Grip Ring for UPVC and PP pipe

07970

Casquillo de apriete para tubos de UPVC y PP

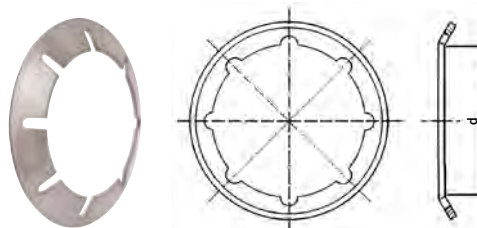

Product Code	Size d	UB	UC	W
07970020	20	—	10000	1
07970025	25	—	10000	2
07970032	32	—	10000	3
07970040	40	—	1000	6
07970050	50	—	1000	10
07970063	63	—	1000	17

Conversion Set for Copper Pipe

07438

Juego adaptador para tubos de cobre

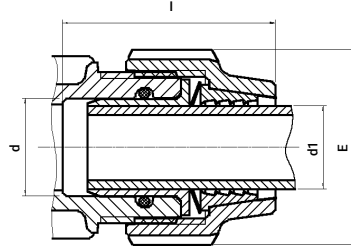

Product Code	Size d x d1	E	I	UB	UC	W
07438015	20 x 15	48	67	10	360	20
07438016	25 x 15	54	69	10	360	33
07438022	25 x 22	54	67	10	360	23
07438028	32 x 28	64	77	10	300	35
07438035	40 x 35	82	92	10	300	38
07438042	50 x 42	96	105	10	250	64
07438054	63 x 54	113	121	1	150	102

CTS dimensions

Dimensiones CTS

Product Code	Size d x d1	E	I	UB	UC	W
07439204	20 x 1/2" (O.D. 15.8mm)	48	67	10	600	20
07439257	25 x 3/4" (O.D. 22.2mm)	54	69	10	500	33

Australian dimensions (AS 1432)

Dimensiones Australianas (AS 1432)

Product Code	Size d x d1	E	I	UB	UC	W
07439205	20 x 15 (1/2") (O.D. 12.7mm)	48	67	10	600	20
07439251	25 x 20 (3/4") (O.D. 19.5mm)	54	69	10	500	33
07439257	25 x 25 (1") (O.D. 25.4mm)	54	69	10	500	33

Conversion Set for Lead Pipe

077802

Juego adaptador para tubos de plomo

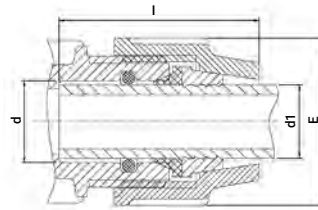

Product Code	Size d x d1	E	I	UB	UC	W
077802025003	25 x 3/8" 5 LB	54	67	5	1000	15
077802025005	25 x 1/2" 7 LB	54	64	5	1500	8
077802032005	32 x 1/2" 9 LB	64	77	5	500	24
077802032007	32 x 3/4" 9 LB	64	76	5	1000	13
077802040007	40 x 3/4" 11 LB	82	95	5	400	42
077802050010	50 x 1" 16 LB	96	104	5	250	68

Converter Rubber Adaptor for Galvanised Pipe

078908*

Conversor de goma para tubos de acero galvanizado

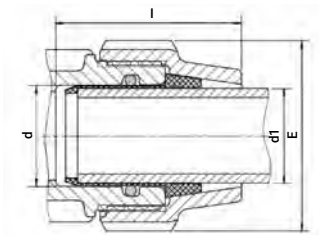

Product Code	Size d x d1	E	I	UB	UC	W
078908010	40 x 1"	82	89	5	200	60
078908013	50 x 1 1/4"	96	98	5	150	89
078908015	50 x 1 1/2"	96	90	5	150	35
078908020	63 x 2"	113	108	5	120	71

* Without pullout resistance | * Extraccion sin resistencia

Conversion Set Adaptor for Galvanised Pipe

078907

Juego de conversion para tubos de acero galvanizado

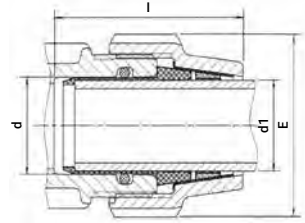

Product Code	Size d x d1	E	I	UB	UC	W
078907010	40 x 1"	82	96	5	200	117
078907013	50 x 1 1/4"	96	105	5	150	150
078907015	50 x 1 1/2"	96	115	5	150	125
078907020	63 x 2"	113	117	5	100	226

Pipe Conversion Chart

Metric PE / Metric U-PVC / Metric PP / Galvanised Steel / Lead Pipe / Imperial U-PVC/Copper

PE métrico / PP y PVCU métrico / Acero galvanizado / Plomo / U-PVC imperial / Cobre...

The basic fitting is a dedicated product for joining metric PE pipe. It will securely join the pipe without any additional components. The fittings can be easily converted for use with other materials simply by adding a conversion set. Plasson offers a full range of conversion sets to provide exceptional adaptability.

El accesorio básico es un producto dedicado a conectar tuberías de PE sin componentes adicionales, con la máxima seguridad. Los accesorios se pueden ser convertidos fácilmente a cualquier tipo de tubería usando un juego de conversión. Plasson ofrece una gama que permite una adaptabilidad excepcional.

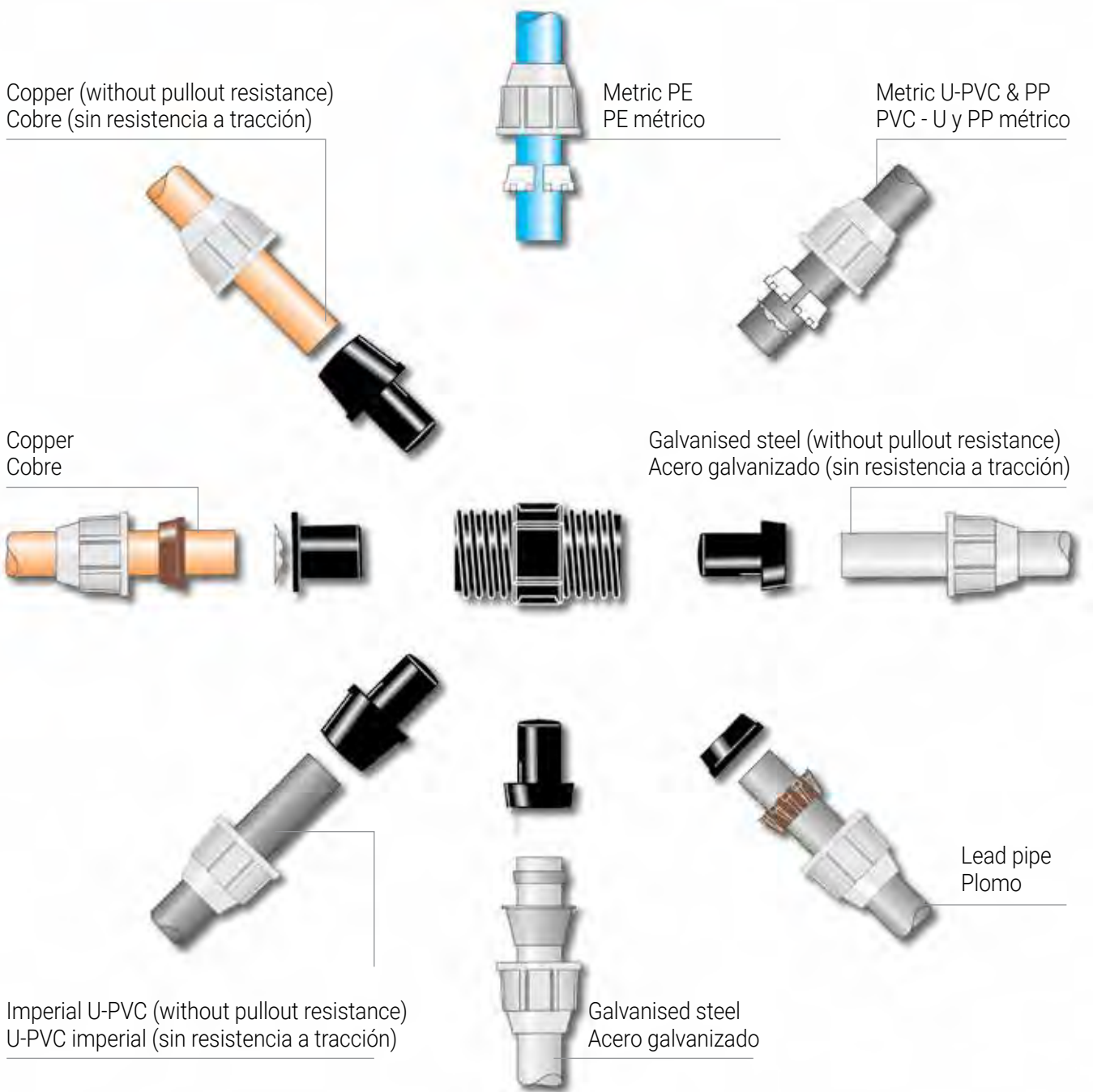

Nut

07004

Racor

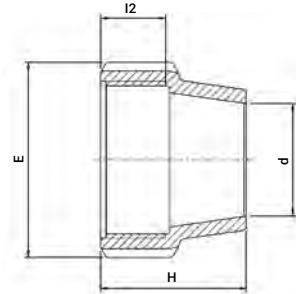

Product Code	Size d	E	H	I2	UB	UC	W
070040016P	16	39	40	23	—	1000	12
070040020P	20	48	45	26	—	700	22
070040025P	25	54	46	26	—	500	26
070040032P	32	64	51	30	—	300	41
070040040P	40	82	63	34	10	200	70
070040050P	50	96	71	34	5	125	104
070040063P	63	113	89	43	5	100	171
070040125P	125	212	185	107	—	10	1135

87004

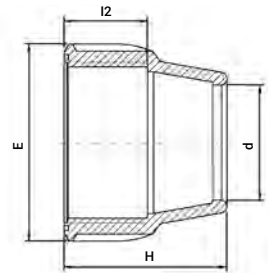

Product Code	Size d	E	H	I2	UB	UC	W
870040075P	75	132	110	56	—	45	293
870040090P	90	153	135	73	—	30	589
870040110P	110	181	170	97	—	16	828

O - Ring NBR

07002

Junta tórica (NBR)

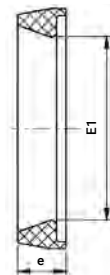

Product Code	Size d	E1	e	UB	UC	W
070020016	16	15	3	—	30000	1
070020020	20	19	3	—	32000	1
070020025	25	24	4	—	12000	1
070020032	32	31	5	—	10000	2
070020040	40	39	6	—	4000	5
070020050	50	49	7	—	2500	8
070020063	63	62	7	—	2000	10
070020075	75	74	8	—	1600	16
070020090	90	89	8	—	1500	17
070020110	110	108	9	—	900	27
070020125	125	122	10	—	700	50
070020160	160	158	12	—	16000	74

O - Ring EPDM (Blue Mark)

07002D0

Junta tórica EPDM, (marca azul)

Product Code	Size d	E1	e	UB	UC	W
07002D016	16	15	3	—	30000	1
07002D020	20	19	3	—	16000	1
07002D025	25	24	4	—	16000	1
07002D032	32	31	5	—	8000	2
07002D075	75	74	8	—	1600	16
07002D090	90	89	8	—	1400	17
07002D110	110	108	9	—	900	27

O - Ring Viton FPM (White Mark)

07002V0

Junta tórica FPM, (marca blanca)

Product Code	Size d	E1	e	UB	UC	W
07002V016	16	15	3	—	—	2
07002V020	20	19	3	—	32000	2
07002V025	25	24	4	—	16000	2
07002V032	32	31	5	—	8000	4
07002V040	40	39	6	—	4000	7
07002V050	50	49	7	—	2500	12
07002V063	63	62	7	—	2000	15
07002V075	75	74	8	—	1600	23
07002V090	90	89	8	—	1400	28
07002V110	110	108	9	—	900	43

Seal - NBR

070029

Sello de NBR



Product Code	Size d	E1	e	UB	UC	W
070029040	40	38	8	—	2600	4
070029050	50	49	9	—	1600	8
070029063	63	62	9	—	1500	9

Seal - EPDM

87910

Sello de EPDM

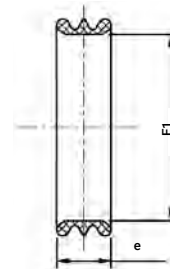

Product Code	Size d	E1	e	UB	UC	W
87910075	75	77	22	—	1600	16
87910090	90	92	22	—	1400	18
87910110	110	112	24	—	900	27

Seal EPDM (Blue Mark)

07002D9

Sello EPDM, (marca azul)

Product Code	Size d	E1	e	UB	UC	W
07002D940	40	38	8	—	4000	4
07002D950	50	49	9	—	2500	7
07002D963	63	62	9	—	2000	9

Seal Viton FPM (White Mark)

07002V9

Sello de Viton FPM, (marca blanca)

Product Code	Size d	E1	e	UB	UC	W
07002V940	40	38	8	—	4000	7
07002V950	50	49	9	—	2500	12
07002V963	63	62	9	—	2000	14

Seal Viton FPM (White Mark)

87920

Sello de Viton FPM, (marca blanca)

Product Code	Size d	E1	e	UB	UC	W
87920075	75	77	22	—	1600	23
87920090	90	92	22	—	1400	28
87920110	110	112	24	—	900	43

Split Ring - Polyacetal

07003

Casquillo de apriete (acetal)

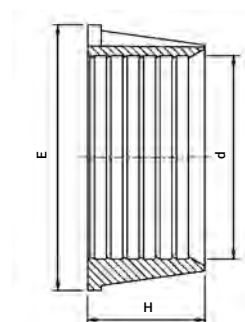

Product Code	Size d	E	H	UB	UC	W
070030016P	16	23	12	100	12000	1
070030020P	20	31	13	100	6500	3
070030025P	25	36	13	100	4500	4
070030032P	32	44	19	50	2000	7
070030040P	40	55	24	50	1200	12
070030050P	50	67	30	20	500	24
070030063P	63	83	37	10	300	46
070030125P	125	161	72	—	35	291

Split Ring - Polyacetal

87003

Casquillo de apriete (acetal)

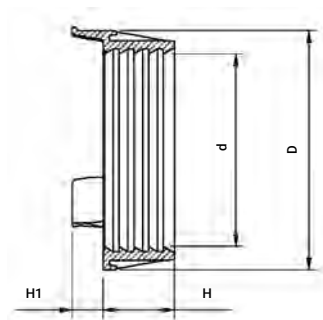

Product Code	Size d	D	H	H1	UB	UC	W
870030075P	75	99	30	14	—	300	53
870030090P	90	115	34	16	—	170	76
870030110P	110	140	42	19	10	100	133

Split Ring - CPVC

07003V

Casquilla de apriete (CPVC)

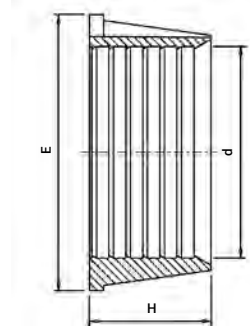

Product Code	Size d	E	H	UB	UC	W
07003V016P	16	23	12	100	12000	3
07003V020P	20	31	13	100	6500	4
07003V025P	25	36	13	100	4500	5
07003V032P	32	44	19	50	1500	11
07003V040P	40	55	24	50	1200	19
07003V050P	50	67	30	20	500	32
07003V063P	63	83	37	10	300	53

Split Ring - CPVC

87003V

Casquilla de apriete (CPVC)

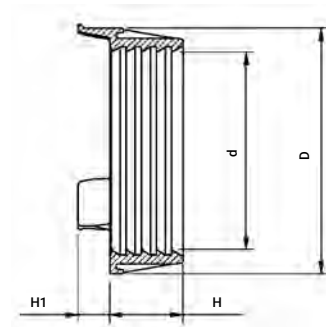

Product Code	Size d	D	H	H1	UB	UC	W
87003V075P	75	99	30	13	—	240	53
87003V090P	90	115	34	14	—	115	90
87003V110P	110	140	42	16	—	70	151

Insert

07005

Inserto de PP

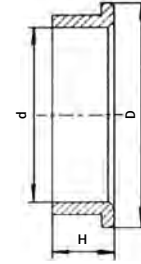

Product Code	Size d	D	H	UB	UC	W
070050016P	16	17	12	100	8700	1
070050020P	20	—	—	100	5000	1
070050025P	25	—	—	100	4000	3
070050032P	32	—	—	100	4000	6
070050075P	75	—	—	—	300	31
070050090P	90	—	—	—	160	56
070050110P	110	—	—	—	100	81
070050125P	125 Upper	164	48	—	80	153
070051125P	125 Lower	142	18	—	160	204

87005

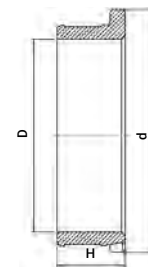

Product Code	Size d	D	H	UB	UC	W
870050075P	75	77	27	—	300	37
870050090P	90	92	31	—	200	48
870050110P	110	113	40	—	100	75

Chamfer Tool for PE Pipes

18960

Herramienta para biselar



Product Code	Size	UB	UC	W
189600063020P	20 - 63	–	64	202

Plasson Wrench

07990

Llave Plasson



Product Code	Size	UB	UC	W
07990001	16 - 40	–	250	65
07990005	40 - 75	–	75	296
07990000	63 - 125	–	40	840

Coupling

070106

Enlace recto

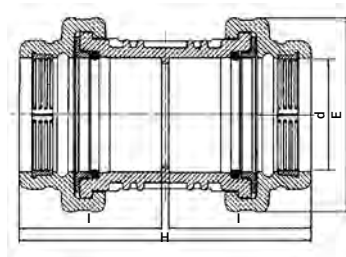

Product Code	Size d x d	E	I	H	UB	UC	W
070106160	160 x 160	280	204	418	–	2	8888

Repair Coupling

076106

Enlace recto de reparación

Product Code	Size d x d	E	I	H	UB	UC	W
076106160	160 x 160	280	–	418	–	2	8838

90° Tee

070406

Te de 90°

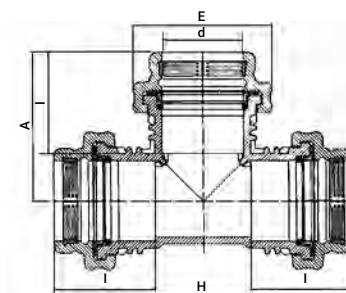

Product Code	Size d x d x d	E	I	H	A	UB	UC	W
070406160	160 x 160 x 160	280	204	601	301	–	1	14660

90° Elbow

070506

Codo de 90°

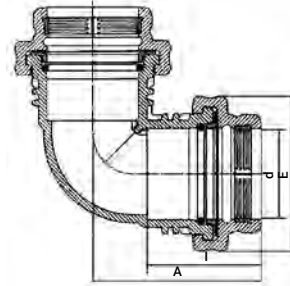

Product Code	Size d x d	E	I	A	UB	UC	W
070506160	160 x 160	280	204	301	—	2	10028

Compression Flange Adaptor (with Metal Flange)

072206

Adaptador compresión-brida (con brida de metal)

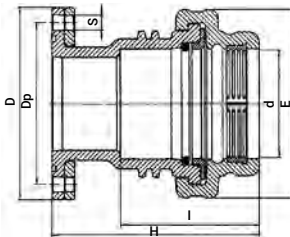

Product Code	Size d x DN (inch)	E	H	I	D	Dp	S	No. of Holes	Metal-Flange Size	UC	W
072206160050	160 x 125 (5")	280	304	204	250	210	18	8	125 / 160 x 125	3	7781
072206160060	160 x 150 (6")	280	304	204	285	240	22	8	125 / 160 x 150	3	9188

Flange Adaptor (with Metal Flange)

072306

Adaptador brida (con brida de metal)

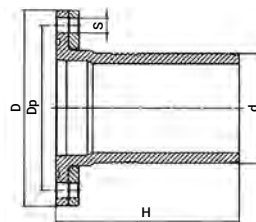

Product Code	Size d x DN (inch)	H	D	Dp	S	No. of Holes	Metal-Flange Size	UC	W
072306160050	160 x 125 (5")	265	250	210	18	8	125 / 160 x 125	6	4409
072306160060	160 x 150 (6")	265	285	240	22	8	125 / 160 x 150	5	5886

Shouldered Adaptor

073206

Adaptador minero

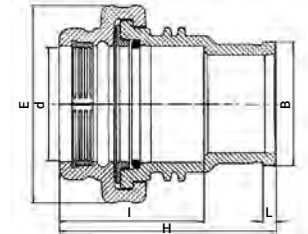

Product Code	Size d x DN (inch)	E	H	I	L	B	UB	UC	W
073206160060	160 x 150 (6")	280	304	204	18	175	—	4	5170

Half Metal Flange

07006

Brida de metal

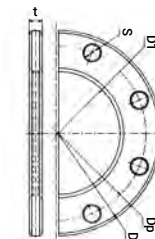

Product Code	Size d x DN (inch)	D	Dp	D1	S	t	Th* (mm)	Th* (inch)	No. of Holes	UC	W
070060160050P	125 / 160 x 125 (5")	250	210	170	18	12	M16	5/8	4	1100	—
070060160060P	125 / 160 x 150 (6")	250	240	170	22	12	M20	3/4	4	1800	—

* Nominal diameter of bolts | * Diametro nominal del tornillo

Saddle Single Outlet with Reinforcing Ring

16076*

Collarin simple con anillo de refuerzo

For more details, see table on page 84, 85

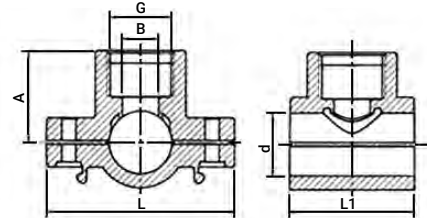

Product Code	Size d x G	B	L	L1	A	No. of Bolts	UB	UC	W
160760020005	20 x 1/2"	10	70	45	33	2	1	400	63
160760025005	25 x 1/2"	15	75	50	36	2	1	300	70
160760025007	25 x 3/4"	15	75	50	37	2	1	300	73
160760032005	32 x 1/2"	16	92	60	40	2	1	150	133
160760032007	32 x 3/4"	19	92	60	41	2	1	150	135
160760032010	32 x 1"	20	92	60	42	2	1	150	142
160760040005	40 x 1/2"	16	92	60	45	2	1	150	141
160760040007	40 x 3/4"	19	92	60	46	2	1	150	143
160760040010	40 x 1"	25	92	60	49	2	1	150	151
160760050005	50 x 1/2"	16	106	73	51	2	1	100	179
160760050007	50 x 3/4"	21	106	73	52	2	1	100	180
160760050010	50 x 1"	25	106	73	54	2	1	100	187
160760050013	50 x 1 1/4"	25	106	73	58	2	1	100	212
160760063005	63 x 1/2"	16	116	84	58	4	1	70	278
160760063007	63 x 3/4"	20	116	84	59	4	1	70	279
160760063010	63 x 1"	25	116	84	61	4	1	70	286
160760063013	63 x 1 1/4"	32	116	84	66	4	1	70	308
160760063015	63 x 1 1/2"	39	116	84	67	4	1	60	322
160760075005	75 x 1/2"	16	122	98	64	4	1	60	369
160760075007	75 x 3/4"	20	122	98	65	4	1	55	369
160760075010	75 x 1"	25	122	98	67	4	1	55	376
160760075013	75 x 1 1/4"	32	122	98	72	4	1	55	398
160760075015	75 x 1 1/2"	40	122	98	73	4	1	50	411
160760075020	75 x 2"	40	122	98	78	4	1	50	433
160760090005	90 x 1/2"	16	141	105	72	4	1	45	453
160760090007	90 x 3/4"	20	141	105	73	4	1	45	454
160760090010	90 x 1"	25	141	105	75	4	1	45	460
160760090013	90 x 1 1/4"	32	141	105	80	4	1	40	483
160760090015	90 x 1 1/2"	40	141	105	81	4	1	40	467
160760090020	90 x 2"	50	141	105	86	4	1	40	511
160760110005	110 x 1/2"	16	165	116	83	4	1	45	561
160760110007	110 x 3/4"	20	165	116	84	4	1	45	562
160760110010	110 x 1"	25	165	116	87	4	1	36	567
160760110013	110 x 1 1/4"	32	165	116	91	4	1	36	588
160760110015	110 x 1 1/2"	40	165	116	92	4	1	36	600
160760110020	110 x 2"	50	165	116	97	4	1	30	615
160760125007	125 x 3/4"	20	184	124	91	6	1	30	749
160760125010	125 x 1"	25	184	124	94	6	1	30	755
160760125013	125 x 1 1/4"	32	184	124	98	6	1	30	778
160760125015	125 x 1 1/2"	40	184	124	99	6	1	30	781
160760125020	125 x 2"	50	184	124	104	6	1	25	796
160760140010	140 x 1"	25	201	136	101	6	1	24	893
160760140013	140 x 1 1/4"	32	201	136	106	6	1	24	912
160760140015	140 x 1 1/2"	40	201	136	107	6	1	24	922
160760140020	140 x 2"	50	201	136	112	6	1	20	938
160760160010	160 x 1"	25	223	145	112	6	1	20	1039
160760160013	160 x 1 1/4"	32	223	145	117	6	1	20	1061
160760160015	160 x 1 1/2"	40	223	145	118	6	1	20	1071
160760160020	160 x 2"	50	223	145	123	6	1	20	1080
160760180010	180 x 1"	25	245	154	122	6	1	16	1300
160760180013	180 x 1 1/4"	32	245	154	127	6	1	16	1319
160760180015	180 x 1 1/2"	40	245	154	128	6	1	16	1349
160760180020	180 x 2"	50	245	154	133	6	1	16	1334

16086 - without reinforcing ring, 16079 - With stainless steel bolts

Saddle Double Outlet with Reinforcing Ring Options

16176*

Collarin doble con anillo de refuerzo

For more details, see table on page 84, 85

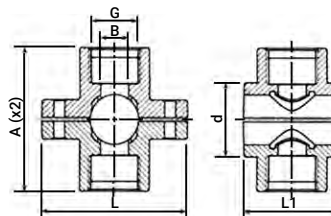

Product Code	Size d x G	B	L	L1	A	No. of Bolts	UB	UC	W
161760020005	20 x 1/2"	10	70	45	66	2	1	300	73
161760025005	25 x 1/2"	15	75	50	71	2	1	250	81
161760025007	25 x 3/4"	15	75	50	73	2	1	250	86
161760032005	32 x 1/2"	16	92	60	80	2	1	140	144
161760032007	32 x 3/4"	19	92	60	82	2	1	140	148
161760032010	32 x 1"	20	92	60	84	2	1	140	163
161760040005	40 x 1/2"	16	92	60	89	2	1	120	153
161760040007	40 x 3/4"	19	92	60	91	2	1	120	157
161760040010	40 x 1"	25	92	60	98	2	1	120	174
161760050005	50 x 1/2"	16	106	73	102	2	1	80	193
161760050007	50 x 3/4"	21	106	73	104	2	1	80	196
161760050010	50 x 1"	25	106	73	109	2	1	80	210
161760050013	50 x 1 1/4"	25	106	73	117	2	1	80	260
161760063005	63 x 1/2"	16	116	84	116	4	1	80	293
161760063007	63 x 3/4"	20	116	84	118	4	1	80	296
161760063010	63 x 1"	25	116	84	123	4	1	70	310
161760063013	63 x 1 1/4"	32	116	84	132	4	1	70	354
161760063015	63 x 1 1/2"	39	116	84	133	4	1	60	382
161760075005	75 x 1/2"	16	122	98	128	4	1	60	382
161760075007	75 x 3/4"	20	122	98	130	4	1	60	382
161760075010	75 x 1"	25	122	98	135	4	1	50	397
161760075013	75 x 1 1/4"	32	122	98	144	4	1	50	438
161760075015	75 x 1 1/2"	40	122	98	145	4	1	50	465
161760075020	75 x 2"	40	122	98	155	4	1	40	513
161760090005	90 x 1/2"	16	141	105	143	4	1	45	467
161760090007	90 x 3/4"	20	141	105	146	4	1	45	468
161760090010	90 x 1"	25	141	105	151	4	1	45	482
161760090013	90 x 1 1/4"	32	141	105	160	4	1	40	526
161760090015	90 x 1 1/2"	40	141	105	162	4	1	40	546
161760090020	90 x 2"	50	141	105	172	4	1	36	585
161760110005	110 x 1/2"	16	165	116	166	4	1	40	575
161760110007	110 x 3/4"	20	165	116	168	4	1	40	577
161760110010	110 x 1"	25	165	116	173	4	1	36	586
161760110013	110 x 1 1/4"	32	165	116	182	4	1	30	628
161760110015	110 x 1 1/2"	40	165	116	187	4	1	30	653
161760110020	110 x 2"	50	165	116	196	4	1	24	685
161760125007	125 x 3/4"	20	184	124	182	6	1	20	814
161760125010	125 x 1"	25	184	124	187	6	1	20	814
161760125013	125 x 1 1/4"	32	184	124	196	6	1	20	814
161760125015	125 x 1 1/2"	40	184	124	198	6	1	20	834
161760125020	125 x 2"	50	184	124	208	6	1	20	861
161760140010	140 x 1"	25	201	136	202	6	1	20	948
161760140013	140 x 1 1/4"	32	201	136	212	6	1	20	947
161760140015	140 x 1 1/2"	40	201	136	213	6	1	20	967
161760140020	140 x 2"	50	201	136	223	6	1	20	1001
161760160010	160 x 1"	25	223	145	223	6	1	16	1055
161760160013	160 x 1 1/4"	32	223	145	233	6	1	16	1098
161760160015	160 x 1 1/2"	40	223	145	235	6	1	16	1119
161760160020	160 x 2"	50	223	145	245	6	1	16	1137
161760180010	180 x 1"	25	245	154	243	6	1	16	1310
161760180013	180 x 1 1/4"	32	245	154	253	6	1	16	1335
161760180015	180 x 1 1/2"	40	245	154	255	6	1	16	1247
161760180020	180 x 2"	50	245	154	265	6	1	16	1368

16186 - without reinforcing ring, 16179 - With stainless steel bolts

Plated Nut & Bolt for Saddles

16005*

Tornillo y tuerca de acero niquelado para collarin



Product Code	Bolts Dimensions/mm	Saddles
16005306	6 x 30	20 - 25
16005458	8 x 45	32 - 40 - 50 - 63
16005608	8 x 60	75 - 90 - 110
16005708	8 x 70	125 - 140 - 160 - 180

* Nuts & Bolts also available in stainless steel | * Tornillos y tuercas, a disposición, en acero inoxidable

Mechanical Tapping Valve

18680

Valvula mecanica con salida rotatoria tapper

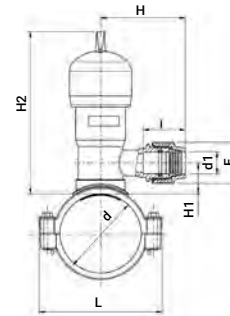

Product Code	Size d x d1	L	L1*	H	H1	H2	E	I	UB	UC	W
186800063032	63 x 32	116	84	135	55	240	64	67	1	8	2090
186800063063	63 x 63	116	84	200	60	240	113	110	1	8	2210
186800075032	75 x 32	122	98	135	60	244	64	67	1	8	1840
186800075063	75 x 63	122	98	200	65	244	113	110	1	8	2230
186800090032	90 x 32	141	105	135	60	244	64	67	1	8	2150
186800090063	90 x 63	141	105	200	65	244	113	110	1	8	2270
186800110032	110 x 32	165	116	135	60	244	64	67	1	8	2270
186800110063	110 x 63	165	116	200	65	244	113	110	1	8	2730
186800125032	125 x 32	184	124	135	60	244	64	67	1	8	2280
186800125063	125 x 63	184	124	200	65	244	113	110	1	8	2390
186800140032	140 x 32	201	136	135	60	244	64	67	1	8	2290
186800140063	140 x 63	201	136	200	65	244	113	110	1	6	2440
186800160032	160 x 32	223	145	135	60	244	64	67	1	6	2490
186800160063	160 x 63	223	145	200	65	244	113	110	1	6	2440
186800180032	180 x 32	245	154	135	60	244	64	67	1	6	2550
186800180063	180 x 63	245	154	200	65	244	113	110	1	4	2550

* L1 - Length along pipe | * L1 - Longitud del collarin

Tapper - for PVC & PE Pipes

18680

Collarin con salida rotatoria Tapper® para tubos de PVC y de PE

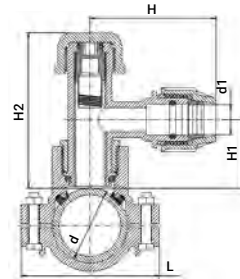

Product Code	Size d x d1	H	L	L1*	H1	H2	No. of Bolts	UB	UC	W
165400063025	63 x 25	105	116	84	57	130	4	1	40	584
165400063032	63 x 32	109	116	84	57	130	4	1	40	614
165400075025	75 x 25	105	122	98	57	130	4	1	30	700
165400075032	75 x 32	109	122	98	57	130	4	1	30	725
165400090025	90 x 25	105	141	105	58	131	4	1	25	761
165400090032	90 x 32	109	141	105	58	131	4	1	25	780
165400110025	110 x 25	105	165	116	59	132	4	1	20	872
165400110032	110 x 32	109	165	116	59	132	4	1	20	902
165400125025	125 x 25	105	184	124	58	131	6	1	16	1058
165400125032	125 x 32	109	184	124	58	131	6	1	16	1088
165400140025	140 x 25	105	201	136	59	132	6	1	14	1228
165400140032	140 x 32	109	201	136	59	132	6	1	14	1228
165400160025	160 x 25	105	223	145	59	132	6	1	10	1370
165400160032	160 x 32	109	223	145	59	132	6	1	10	1400
165400180025	180 x 25	105	245	154	60	133	6	1	8	1606
165400180032	180 x 32	109	245	154	60	133	6	1	8	1640

* L1 - Length along pipe | * L1 - Longitud del collarin

Tapper® - Brass Cutter for PVC & PE Pipes (including O-Ring)

165400012

Cortatubo para tubos de PVC (con junta tórica)

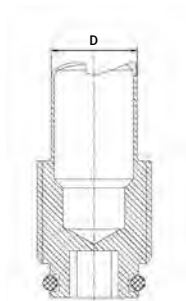

Product Code	Size d	A	UB	UC	W
165400012	63 x 180mm	20	-	-	94

Saddle Seal for Tapper® (EPDM)

16532

Sello de collarín Tapper® (EPDM)



Product Code	Size One Size	e	D	H	UB	UC	W
16532015	63 x 180mm	36	60	7	-	500	12

Stainless Steel Nuts & Bolts for Saddles

16007

Tuercas y tornillos en acero inoxidable para collarín



Product Code	Bolts Dimensions/mm	Saddles
16007457	8 x 45	63
16007607	8 x 60	75 - 90 - 110
16007707	8 x 70	125 - 140 - 160 - 180

Threaded Socket

050107*

Manguito rosca hembra x hembra

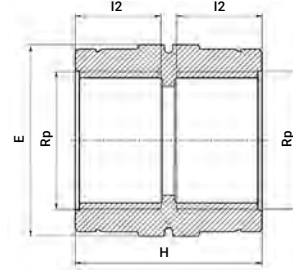

Product Code	Size Rp x Rp	H	I2	E	UB	UC	W
050107005	1/2" x 1/2"	39	17	30	10	1200	15
050107007	3/4" x 3/4"	41	19	36	10	1000	19
050107010	1" x 1"	45	21	46	10	600	31
050107013	1 1/4" x 1 1/4"	54	25	60	10	250	65
050107015	1 1/2" x 1 1/2"	54	25	65	10	250	76
050107020	2" x 2"	66	31	75	5	150	92

* With reinforcing ring - Cat. No. 050117 | * Con anillo de refuerzo - Cat. No. 050117

Threaded Reducing Bushing

050207

Manguito reductor hembra x macho

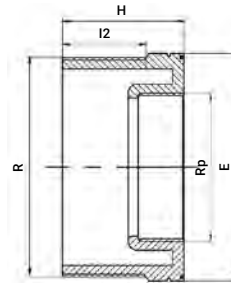

Product Code	Size R x Rp	H	I2	E	UB	UC	W
050207007005	3/4" x 1/2"	30	17	27	10	2000	6
050207010005	1" x 1/2"	32	19	36	10	1200	16
050207010007	1" x 3/4"	32	19	36	10	1000	11
050207013005	1 1/4" x 1/2"	37	21	46	10	700	27
050207013007	1 1/4" x 3/4"	37	21	46	10	700	28
050207013010	1 1/4" x 1"	37	21	46	10	700	21
050207015005	1 1/2" x 1/2"	37	21	50	10	600	34
050207015007	1 1/2" x 3/4"	37	21	50	10	600	32
050207015010	1 1/2" x 1"	37	21	50	10	500	32
050207015013	1 1/2" x 1 1/4"	37	21	50	10	500	20
050207020005	2" x 1/2"	41	25	63	5	350	60
050207020007	2" x 3/4"	41	25	63	5	350	58
050207020010	2" x 1"	41	26	63	5	300	61
050207020013	2" x 1 1/4"	41	26	63	5	320	55
050207020015	2" x 1 1/2"	41	26	63	5	320	44
050207025020	2 1/2" x 2"	44	29	80	5	200	75
050207030010	3" x 1"	48	32	90	2	150	117
050207030013	3" x 1 1/4"	48	32	90	2	150	119
050207030015	3" x 1 1/2"	48	32	90	2	150	118
050207030020	3" x 2"	48	32	90	2	100	103
050207030025	3" x 2 1/2"	48	32	90	2	150	75
050207040020	4" x 2"	56	41	120	2	80	238
050207040030	4" x 3"	56	41	120	2	80	222

90° Threaded Tee

050407*

Te de 90° rosca hembra

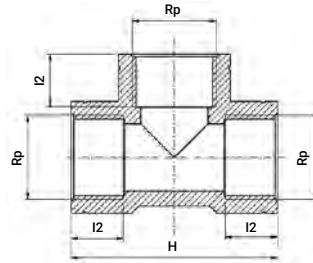

Product Code	Size Rp	H	I2	UB	UC	W
050407005	1/2"	64	18	10	700	28
050407007	3/4"	68	19	10	500	39
050407010	1"	81	21	10	260	61
050407013	1 1/4"	96	25	5	140	114
050407015	1 1/2"	108	25	5	90	157
050407020	2"	130	30	5	60	205

* With reinforcing ring - Cat. No. 050417 | * Con anillo de refuerzo - Cat. No. 050417

90° Threaded Elbow

050507*

Codo de 90° rosca hembra

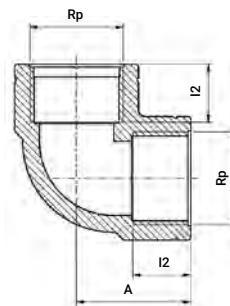

Product Code	Size Rp x Rp	A	I2	UB	UC	W
050507005	1/2" x 1/2"	32	17	10	1000	22
050507007	3/4" x 3/4"	35	18	10	700	30
050507010	1" x 1"	41	21	10	400	45
050507013	1 1/4" x 1 1/4"	48	25	10	200	87
050507015	1 1/2" x 1 1/2"	54	25	5	150	116
050507020	2" x 2"	65	30	5	80	157

* With reinforcing ring - Cat. No. 050517 | * Con anillo de refuerzo - Cat. No. 050517

90° Threaded Elbow Male x Female

051507

Codo roscado-macho x hembra

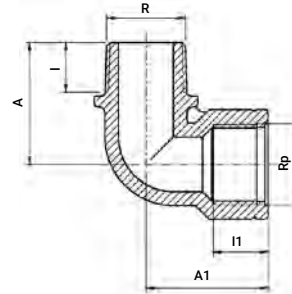

Product Code	Size R x Rp	A	A1	I	I1	UB	UC	W
051507005	1/2" x 1/2"	36	36	16	17	10	1000	17
051507007	3/4" x 3/4"	40	40	17	18	10	700	25
051507010	1" x 1"	45	47	19	21	10	400	40

Threaded Reducing Nipple

050605

Machón doble reductor

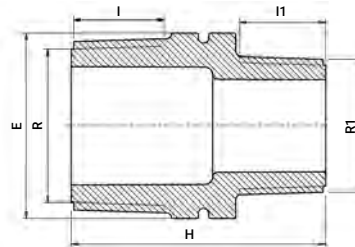

Product Code	Size R x R1	H	I	I1	E	UB	UC	W
050605007005	3/4" x 1/2"	47	17	16	27	10	1500	10
050605010005	1" x 1/2"	49	19	16	36	10	800	17
050605010007	1" x 3/4"	50	19	17	36	10	800	18
050605013005	1 1/4" x 1/2"	53	21	16	46	10	500	28
050605013007	1 1/4" x 3/4"	54	21	17	46	10	500	29
050605013010	1 1/4" x 1"	56	21	19	46	10	500	31
050605015005	1 1/2" x 1/2"	54	21	16	50	5	500	34
050605015007	1 1/2" x 3/4"	55	21	17	50	5	500	34
050605015010	1 1/2" x 1"	57	21	19	50	5	400	36
050605015013	1 1/2" x 1 1/4"	59	21	21	50	5	400	39
050605020005	2" x 1/2"	58	25	16	63	5	280	51
050605020007	2" x 3/4"	59	25	17	63	5	260	52
050605020010	2" x 1"	61	25	19	63	5	260	53
050605020013	2" x 1 1/4"	63	25	21	63	5	240	57
050605020015	2" x 1 1/2"	63	25	21	63	5	240	58

Threaded Nipple

050607

Machón doble

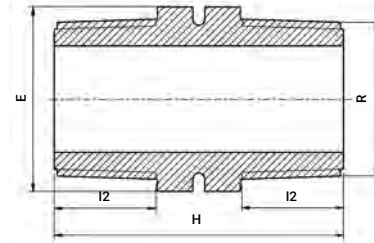

Product Code	Size R x R	H	I2	E	UB	UC	W
050607005	1/2" x 1/2"	47	17	22	10	2000	8
050607007	3/4" x 3/4"	49	18	27	10	1500	11
050607010	1" x 1"	55	20	36	10	800	23
050607013	1 1/4" x 1 1/4"	60	22	46	10	400	35
050607015	1 1/2" x 1 1/2"	61	22	50	5	300	48
050607020	2" x 2"	71	26	65	5	180	78

Threaded Cap

050707

Machón doble

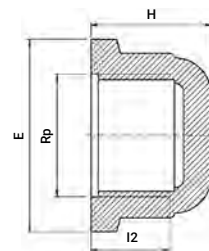

Product Code	Size Rp	E	H	I2	UB	UC	W
050707005	1/2"	37	25	15	10	1600	13
050707007	3/4"	42	26	16	10	1500	14
050707010	1"	50	32	19	10	800	27
050707013	1 1/4"	59	34	22	10	500	39
050707015	1 1/2"	65	34	21	10	450	43
050707020	2"	80	39	25	5	250	78

Threaded Reducing Socket

051107

Manguito reductor rosca hembra - hembra

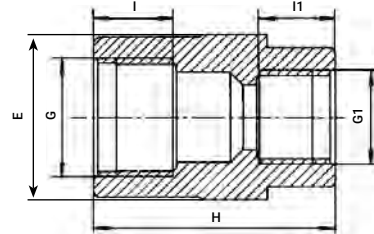

Product Code	Size G x G1	H	I	I1	E	UB	UC	W
051107007005	3/4" x 1/2"	50	20	19	36	10	800	25

Threaded Riser

051607

Espiga roscada

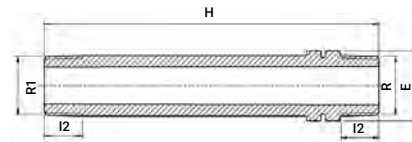

Product Code	Size R x R1	H	I2	E	UB	UC	W
051607005	1/2" x 1/2"	150	17	22	10	600	30
051607007005	3/4" x 1/2"	113	18	27	10	500	26
051607007	3/4" x 3/4"	150	18	27	10	400	43
051607010	1" x 1"	150	19	36	5	250	65
051607013	1 1/4" x 1 1/4"	150	21	46	5	150	93
051607015013	1 1/2" x 1 1/4"	150	21	50	5	140	115
051607015	1 1/2" x 1 1/2"	150	21	50	5	140	120

Threaded Plug

051707

Tapón rosca macho

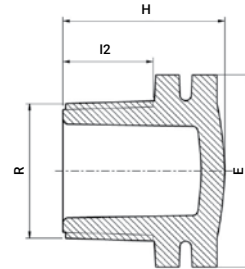

Product Code	Size R	H	I2	E	UB	UC	W
051707003	3/8"	24	13	22	10	4500	4
051707005	1/2"	29	16	27	10	2500	8
051707007	3/4"	31	17	32	10	1500	12
051707010	1"	34	19	36	10	1000	16
051707013	1 1/4"	38	21	46	10	700	26
051707015	1 1/2"	39	21	55	10	500	38
051707020	2"	45	25	65	10	300	60



BALL VALVE 03703

FULL BORE BALL VALVE
WITH A DRAIN PORT OPTION!

* Optional drain ports ISO 7-1 Rp thread

FEATURES AND BENEFITS

- Full bore design minimizing pressure loss
- Various drainage options
- Rated PN16/231 PSI
- Glass Reinforced Polyamide body



PLASSON'S BALL VALVE is produced entirely of plastic, eliminating the risk of corrosive damage to the system

PLASSON'S BALL VALVE features an option for two drain ports or no drain ports. Ideally suited for draining or sampling of potable water systems and monitoring system pressure, Plasson's valves allow simple and direct connections to hoses without tampering with the system line.

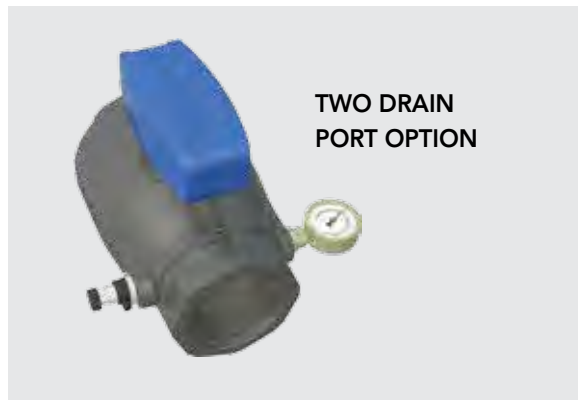

Ball Valve

NEW!

03703

Válvula esférica

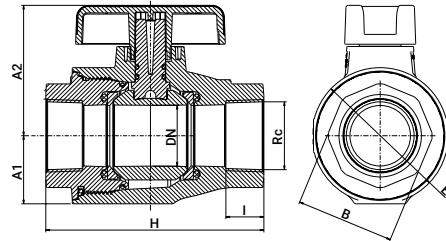

Product Code	Size DN x Rc	H	E	I	B	A1	A2	UB	UC	W
0370300007	20 x 3/4"	97	53	18	36	27	54	—	72	175
0370300010	25 x 1"	116	64	21	46	33	64	—	72	313
0370300013	32 x 1 1/4"	118	73	20	55	36	70	—	48	393
0370300015	40 x 1 1/2"	144	91	24	65	45	87	—	30	712
0370300020	50 x 2"	162	100	29	75	53	97	—	24	918

* 037030F - with drain port

Threaded Stoptap (Seal NBR)

03405

Válvula de línea rosca hembra (juntas NBR)

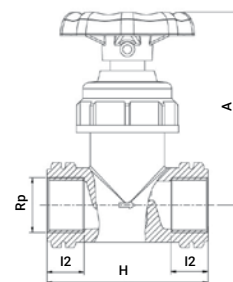

Product Code	Size Rp x Rp	H	I2	A	UB	UC	W
03405077	3/4" x 3/4"	78	18	95	5	140	115
03405110	1" x 1"	82	20	95	5	120	129

Compression Stoptap (Seal NBR)

03407

Válvula de línea compresión (juntas NBR)

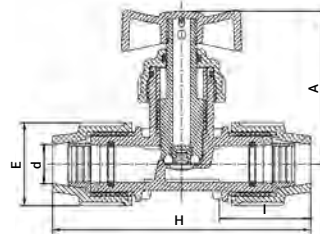

Product Code	Size d	E	H	I	A	UB	UC	W
03407020	20 x 20	48	147	47	87	5	100	168
03407025	25 x 25	54	154	49	87	5	80	190
03407032	32 x 32	64	174	57	87	5	60	260

Angle Seat Valve (Seal NBR) Threaded x Compression 03048/03948*

Válvula de asiento angular - compresión - rosca macho - juntas NBR

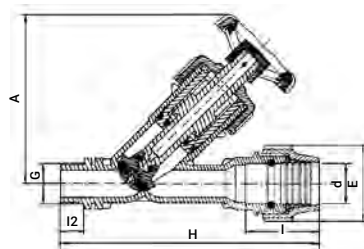

Product Code	Size G x G	E	H	I	I2	A	UB	UC	W
03048200	20 x 1/2"	48	174	57	16	113	5	100	176
03048250	25 x 3/4"	54	187	60	18	121	5	80	238
03048320	32 x 1"	64	212	70	20	140	—	50	360
03948400	40 x 1 1/4*	82	299	84	22	180	—	26	605
03948505	50 x 1 1/2*	96	259	93	22	207	—	17	924
03948630	63 x 2*	113	340	110	26	246	—	10	1518

* Trapeze shaped

Angle Seat Valve (Seal NBR) Threaded Inlet & Outlet

03047*

Válvula de asiento angular, (sello NBR) roscas macho

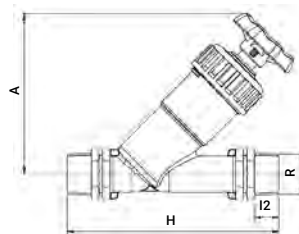

Product Code	Size R x R	H	I2	A	UB	UC	W
03047055	1/2" x 1/2"	135	16	113	5	120	142
03047077	3/4" x 3/4"	151	18	121	5	100	186
03047110	1" x 1"	170	20	140	—	70	280
03047188	1 1/4" x 1 1/4"	225	22	207	—	40	474
03047155	1 1/2" x 1 1/2"	200	22	180	—	24	733
03047220	2" x 2"	254	26	246	—	15	1191

* Available with NPT thread | * Disponible con rosca NPT

Angle Seat Valve (Seal FPM) Threaded Inlet & Outlet

03049*

Válvula de asiento angular, (sello FPM) roscas macho

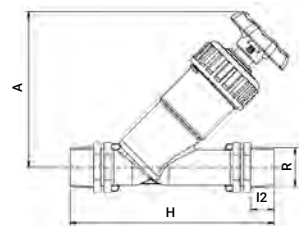

Product Code	Size R x R	H	I2	A	UB	UC	W
03049055	1/2" x 1/2"	135	16	113	5	120	136
03049077	3/4" x 3/4"	151	18	121	5	100	191
03049110	1" x 1"	170	20	140	—	70	294
03049188	1 1/4" x 1 1/4"	200	22	180	—	40	733
03049155	1 1/2" x 1 1/2"	225	22	207	—	24	474
03049220	2" x 2"	254	26	246	—	15	1207

* Available with NPT thread | * Disponible con rosca NPT

Angle Seat Valve (Seal NBR) Compression Inlet & Outlet

03046

Válvula de asiento angular, (sello NBR) compresión

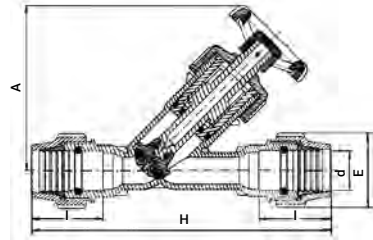

Product Code	Size d x d	E	H	I	A	UB	UC	W
03046320	32 x 32	64	254	70	140	—	40	438

Check Valve (Seal EPDM) Threaded Inlet & Outlet

03067/03068*

Válvula antirretorno, (sello EPDM) roscas macho

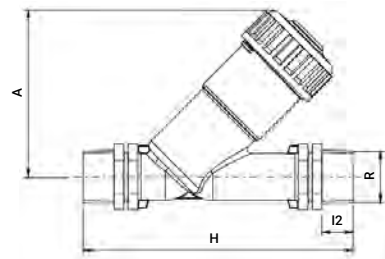

Product Code	Size R	H	I2	A	UB	UC	W
03067077	3/4" x 3/4"	151	18	96	5	140	141
03067110	1" x 1"	170	20	106	5	100	210
03067188	1 1/4" x 1 1/4"	200	22	134	—	55	382
03067155	1 1/2" x 1 1/2"	225	22	155	—	35	586
03067220	2" x 2"	254	26	182	—	20	975

* Available with NPT thread | * Disponible con rosca NPT

Quick Coupling Valve (Seal NBR)

03039

Válvula de acople rápido (juntas NBR)

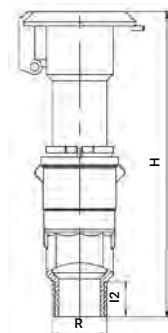

Product Code	Size R	H	I2	UB	UC	W
03039037	3/4"	152	17	5	130	146
03039030	1"	154	18	5	130	148

Key for Quick Coupling Valve 3039

03139

Conexión de acople rápido

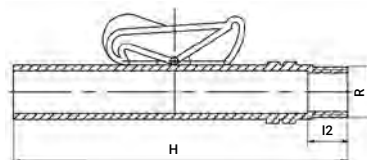

Product Code	Size R	H	I2	UB	UC	W
03139020	3/4"	173	18	5	250	66

Check Valve Insert

03226/03227

Válvula de antirretorno

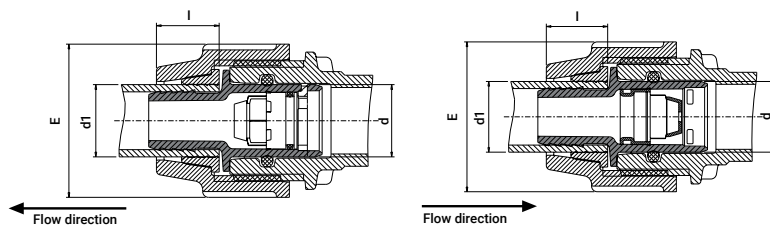

Product Code	Size d x d1	E	I	UB	UC	W
03226025	25 x 25	63	22	-	800	15

BSPT Record for Water Meter

03589

Tubo y tuerca BSPT

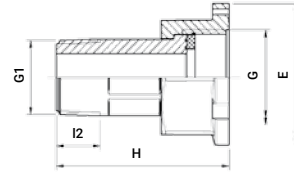

Product Code	Size G x G1	E	H	I2	UB	UC	W
0358906005	3/4" x 1/2"	40	56	16	—	200	60
0358906007	1" x 3/4"	48	61	16	—	200	92

Water Meter Manifold

03510

Soporte para control de flujo de agua

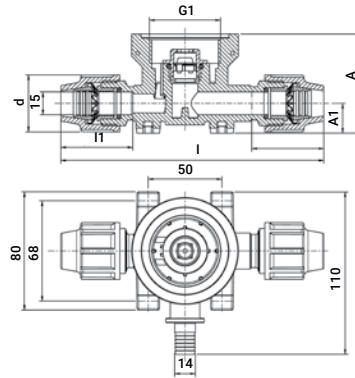

Product Code	Size d x G1 x d	I	I1	A	UB	UC	W
03510000	15 x 1 1/2" x 15	178	49	67	—	100	100

Quarter Turn Valve Male Threaded x Compression

03010

Rosca Macho/ Compresión

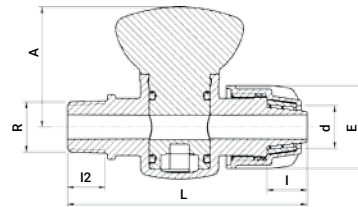

Product Code	Size d x R	L	A	E	I	I1	UB	UC	W
03010516	16 x 1/2"	98	49	34	17	15	10	450	68
03010716	16 x 3/4"	99	49	34	17	17	10	400	74

Quarter Turn Valve Male Threaded x Female Threaded

03012

Rosca Macho-/Rosca Hembra

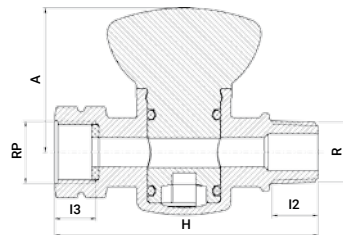

Product Code	Size R x RP	H	A	I1	I2	UB	UC	W
03012055	1/2" x 1/2"	89	49	15	14	10	450	46
03012077	3/4" x 3/4"	97	49	17	18	10	400	73

Quarter Turn Valve Compression x Compression

03017

Compresión

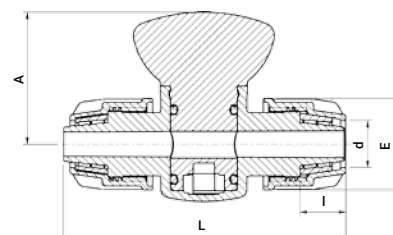

Product Code	Size d x d	L	A	E	I	UB	UC	W
03017016	16 x 16	105	49	34	17	10	350	70

Technical Specifications and Installation Instructions

Technical Specifications

Materials

Compression Fittings

Body: Polypropylene, high-grade copolymer.
 Nut: Polypropylene, high-grade copolymer.
 Split Ring: Acetal POM (CPVC also available).
 Liner: Acetal (POM).
 Seal: Nitrile rubber NBR (EPDM, FPM also available).
 Reinforcing ring: Stainless steel on all female offtakes from 1 1/4" up to 4".
 Bolts (Series 17): Plated steel.
 Nuts (Series 17): Stainless steel.

Valves

Body: Polypropylene, high-grade copolymer.
 O-Ring: See inside.
 Spring: (items 03067, 03039), Stainless steel.

Saddles

Body: Polypropylene, high-grade copolymer.
 Bolts and Nuts: Plated steel.
 (Stainless steel bolts and nuts also available)
 Reinforcing Rings: Stainless steel.
 Seal: Nitrile rubber (NBR).

Tappers + Compression Saddles Body: Polypropylene, high-grade copolymer.
 Split Rings: Acetal (POM, CPVC also available).
 Nuts: Polypropylene, high-grade copolymer.
 Bolts and Nuts: Stainless Steel.
 Seal: EPDM.

Threaded Fittings

Body: Polypropylene, high-grade copolymer.
 Reinforcing Ring: Stainless Steel.

Operating Temperatures

The fittings and valves are not to be used with hot water, although they withstand the same temperature as the polyethylene pipe itself. The fittings and valves will withstand sub-zero temperatures.

Chemical Resistance

Plasson Fittings are supplied, as standard, with polyacetal split rings and NBR O-rings which are suitable for water. For aggressive chemical applications CPVC split rings and EPDM or FPM O-rings can be supplied to produce a better chemical resistance.

Operating Pressures and Quality Certificates

Plasson Fittings are tested and approved according to ISO 17885 for water (replaced ISO 14236) and AS/NZ 4129. For detailed pressure classification see page 84.

Threads

All threads conform to ISO-7/1, BS 21 - 1973, DIN 2999, NEN 3258, AS 1722 Part 1 - 1975.

All internal (female) threads smaller than 3" are parallel. All other threads (male and female) are tapered.

Flanges

Flange dimensions in accordance with: ISO 7005-1 (TABLE 11), BS 4504: 1989 (TABLE 11), DIN 2501 (PN 16 TABLE), AS/NZS 4331. Metal backing rings to be used with all flanges.

Legend	
UB	Units per bag
UC	Units per carton
W	Weight in grams

Note

Before installation ensure that the end of the pipe to be inserted into the fitting is free of scratches and other imperfections and that both the pipe and the fitting itself are clean of sand, mud, stones etc.

Do not over tighten nut when closing. Never use wrenches or spanners with handle lengths longer than 46 cm - excessive torque during tightening can spread nut cone and result in pull outs.

If fittings are reused, ensure split ring is sharp and bites into pipe to avoid pull outs. Alternatively replace split ring.

Pull out resistance of Series 7 fittings combined with the UPVC/PP grip ring has been approved by pressure testing UPVC/PP pipe assemblies at 25 bar operating pressure for at least 1 hour.

Note: We strongly recommend the use of PTFE tape in threaded connections.

Especificaciones Técnicas

Materiales

Accesorios de compresión

Cuerpo: Polipropileno, block copolímero de alta calidad.
 Racor: Polipropileno, block copolímero de alta calidad.
 Casquillo de apriete: Acetal (POM).
 Disponibles también en PVC-C.
 Refuerzo interno de tubos: Acetal (POM).
 Junta tórica: Nitrilo (NBR).
 disponibles también en EPDM y FPM
 Anillo de refuerzo: Acero inoxidable en todas las
 tomas roscadas hembra de 1 1/4" a 4".
 Tornillos (Series 17): Acero niquelado.
 Tuercas: Acero inoxidable.

Válvulas

Cuerpo: Polipropileno, block copolímero de alta calidad.
 Junta tórica: Ver catálogo.
 Resorte: (03067, 03039), Acero inoxidable.

Collarines

Cuerpo: Polipropileno, block copolímero de alta calidad.
 Tornillos y tuercas: Acero niquelado.
 (También se dispone de tornillos y tuercas de acero
 inoxidable)
 Anillo de refuerzo: Acero inoxidable.
 Juntas: NBR.

Tapper y Collarín de compresión

Cuerpo: Polipropileno, block copolímero de alta calidad.
 Casquillo de apriete: Acetal (POM).
 disponibles también en PVC -C
 Racor: Polipropileno, block copolímero de alta calidad.
 Tornillos y tuercas: Acero inoxidable.
 Juntas: EPDM.

Accesorios roscados

Cuerpo: Polipropileno, block copolímero de alta calidad.
 Anillo de refuerzo: Acero inoxidable.

Temperaturas de Trabajo

Los accesorios y las válvulas no son recomendados para
 usar con agua caliente, aunque soportan las mismas
 temperaturas que las propias tuberías de polietileno.
 Sin embargo pueden resistir temperaturas inferiores a los
 cero grados centígrados.

Resistencia a las Sustancias Químicas

Los accesorios Plasson están provistos, como estándar, con
 Casquillos de Apriete de resina acetálica y Juntas tóricas de
 NBR, recomendados para usar con agua potable. Para las
 aplicaciones de productos químicos agresivos se ofrecen
 Casquillos de Apriete de CPVC y Juntas tóricas de EPDM
 o FPM, que resisten mejor a las sustancias químicas.

Presiones de Funcionamiento y Certificados de Calidad

Todos los accesorios de Plasson se someten a pruebas de
 aprobación, de conformidad con las normativas ISO 17885
 - Agua (Reemplaza a la ISO 14236) y AS/NZ 4129. Para ver
 una clasificación detallada de las presiones, consulte la
 página 85.

Roscas

Todas las roscas responden a las normas ISO-7/1, BS 21, DIN
 2999, NEN 3258, AS 1722
 Part 1 - 1975.

Solo las roscas hembra menores a 3" no son cónicas.
 Todas las otras roscas macho y hembra son cónicas.

Bridas

Las dimensiones de las bridas responden a las normas ISO
 7005-1 (TABLE 11),
 BS 4504:1989 (TABLE 11), DIN 2501 (PN 16 TABLE), AS/NZS
 4331.
 Con todas las bridas debe ser utilizado como refuerzo una
 brida de metal.

Legend

UB	Unidades por bolsa
UC	Unidades por carton
W	Peso en gramos

Nota

Antes de la instalación asegure que:

El extremo del tubo introducido no tenga imperfecciones o
 rayaduras Tanto el tubo como el accesorio no tenga sobre
 los mismos arena, barro o piedras, etc. No cierre el racor con
 extremada fuerza, nunca use llaves con manijas más largas
 de 46 cm. Un excesivo momento de torsión durante el cierre
 puede dañar el cono del racor y como resultado del mismo
 no permitir su propio funcionamiento Si los accesorios son
 usados nuevamente después de su desarmado, constate que
 los dientes del casquillo de apriete permanecen afilados y se
 hincan en el tubo impidiendo el escape del tubo. Si no es así,
 cambie el casquillo de apriete.

La resistencia a tracción de accesorios de Serie 7 que
 combinan el uso de casquillo de apriete para tubos de UPVC
 / PP ha sido aprobada por medio de pruebas de presión para
 tubos UPVC / PP con una presión de operación de 25 bar
 durante al menos 1 hora

Nota: Recomendamos utilizar cinta de PTFE para sellar todas
 las conexiones roscadas.

Technical Specifications

Pressure Rating of Plasson Mechanical Fittings and Valves

Product Code	Body Type	Pressure Rating	Stainless Steel Reinforcement Ring	From Pipe Diameter	To Pipe Diameter	From Thread	To Thread	From Outlet Size	To Outlet Size
Starts with 07 and 87	All Fitting Types	16.0							
Exceptions:									
Starts with 07	All 160 mm Fittings	10.0							
Starts with 07 and 87	All Fittings with 3 inch Female Thread	10.0							
Starts with 07 and 87	All Fittings with 4 inch Female Thread	6.0							
0701070/ 0705070	Class 4 (Universal)	10.0		50	50			35	50
0704P	90° Slip Tee	12.5		40	63				
07120	Plug Adaptor	12.5		20	63				
07220	Compression Flange Adaptor	12.5		125	125				
07250	Threaded Adaptor	12.5		75	75	1.1/2	3		
07640	45° Tee	8.0		63	110				
87930	Reducing Set 110X63	10.0							
03046/03047/03048/03049	Angle Seat Valve	8.0							
03405	Threaded Stoptap	10.0				3/4	1		
03407	Compression Stoptap	16.0		20	32				
03039	Quick Coupling Valve	10.0				3/4	1		
Starts with 05	Female Thread	16.0	NO			1/2	1		
Starts with 05	Female Thread	10.0	NO			1.1/4	2		
Starts with 05	Female Thread	16.0	YES			1.1/4	2		
050207/ 050707	Threaded Reducing Bushing/Threaded Cap	10.0				1.1/4	4		
050207/ 050707	Threaded Reducing Bushing/Threaded Cap	16.0				1/2	1		
050605/ 050607	Threaded Reducing Nipple/Threaded Nipple	16.0				1/2	2		
051607	Threaded Riser	16.0				1/2	1.1/2		
051707	Threaded Plug	16.0				1/2	2		
03067	Check Valve	8.0							
160760	Saddle Single Outlet	12.5	YES	20	63	1/2	1.1/2		
160760	Saddle Single Outlet	12.5	YES	75	180	1/2	3/4		
160760	Saddle Single Outlet	10.0	YES	75	180	1	2		
160761	Saddle Single Outlet	16.0	YES	40	180	1	1		
160860	Saddle Single Outlet	6.0	NO	20	180	1.1/4	2		
160860	Saddle Single Outlet	10.0	NO	20	180	1/2	1		
161760	Saddle Double Outlet	12.5	YES	20	63	1/2	1.1/2		
161760	Saddle Double Outlet	12.5	YES	75	180	1/2	3/4		
161760	Saddle Double Outlet	10.0	YES	75	180	1	2		
161860	Saddle Double Outlet	6.0	NO	20	180	1.1/4	2		
161860	Saddle Double Outlet	10.0	NO	20	180	1/2	1		
16279	Saddle Single Outlet	16.0	YES	63	180	1.1/2	1.1/2		
16540	All Tappers - for PVC & PE Pipes	16.0							
16810/16820/16830/16860	All Compression Saddles	16.0							

Especificaciones Técnicas

Presiones Nominales (PN) de Los Accesorios y Válvulas Mecánicos/de Compresión de Plasson

Product Code	Tipo	Presión Nominal	Anillo de Refuerzo de Acero Inoxidable	Desde Diámetro	Hasta Diámetro	Desde Diámetro	Hasta Rosca	Desde Diámetro de Salida	Hasta Diámetro de Salida
Comienza con 07 y 87	Todos Los Accesorios	16.0							
Excepciones:									
Comienza con 07	Accesorios de 160 mm	10.0							
Comienza con 07 y 87	Accesorios con rosca Hembra de 3"	10.0							
Comienza con 07 y 87	Accesorios con rosca Hembra de 4"	6.0							
0701070/ 0705070	Plass 4 (Universal)	10.0		50	50			35	50
0704P	Te de 90° de Reparación	12.5		40	63				
07120	Tapón Final	12.5		20	63				
07220	Adaptador Compresión-Brida	12.5		125	125				
07250	Adaptador Compresión Rosca Macho	12.5		75	75	1.1/2	3		
07640	Te de 45°	8.0		63	110				
87930	Reducing Set 110X63	10.0							
03046/03047/03048/03049	Válvula de Asiento Angular	8.0							
03405	Válvula de Línea Rosca Hembra	10.0				3/4	1		
03407	Válvula de Línea Compresión	16.0		20	32				
03039	Quick Coupling Valve	10.0				3/4	1		
Comienza con 05	Rosca Hembra	16.0	NO			1/2	1		
Comienza con 05	Rosca Hembra	10.0	NO			1.1/4	2		
Comienza con 05	Rosca Hembra	16.0	SI			1.1/4	2		
050207/ 050707	Manguito Roscado/Tapón Rosca Hembra	10.0				1.1/4	4		
050207/ 050707	Manguito Roscado/Tapón Rosca Hembra	16.0				1/2	1		
050605/ 050607	Machón Doble Reductor/Machón Doble	16.0				1/2	2		
051607	Espiga Roscada	16.0				1/2	1.1/2		
051707	Tapón Rosca Macho	16.0				1/2	2		
03067	Check Valve	8.0							
160760	Collarín Simple	12.5	SI	20	63	1/2	1.1/2		
160760	Collarín Simple	12.5	SI	75	180	1/2	3/4		
160760	Collarín Simple	10.0	SI	75	180	1	2		
160761	Collarín Simple	16.0	SI	40	180	1	1		
160860	Collarín Simple	6.0	NO	20	180	1.1/4	2		
160860	Collarín Simple	10.0	NO	20	180	1/2	1		
161760	Collarín Doble	12.5	SI	20	63	1/2	1.1/2		
161760	Collarín Doble	12.5	SI	75	180	1/2	3/4		
161760	Collarín Doble	10.0	SI	75	180	1	2		
161860	Collarín Doble	6.0	NO	20	180	1.1/4	2		
161860	Collarín Doble	10.0	NO	20	180	1/2	1		
16279	Collarín Doble	16.0	SI	63	180	1.1/2	1.1/2		
16540	Todos los Collarines con Tapper para Tubos PVC y PE	16.0							
16810/16820/16830/16860	Todos los collarines de compresión	16.0							

Installation Instructions for Compression Fittings

ASSEMBLY AS SIMPLE AS ABC...

For Fittings 16mm - 63mm / Para accesorios de 16mm - 63mm

Cut the pipe square, remove burrs • Undo the nut to the last thread. Leave the nut on the fitting while inserting the pipe.

Corte el tubo al tamaño requerido y realice el biselado al final del tubo • Retire el racor hasta su última rosca dejándolo en el accesorio durante el próximo paso.



Twist the pipe into the fitting* through the split ring and rubber seal to the pipe stop • Tighten the nut firmly. Use a Plasson wrench (or similar tool) for final tightening of sizes 40 and above.

Introduzca el tubo con un movimiento circular dentro del accesorio pasando el casquillo de apriete y el sello hasta llegar al tope interno del accesorio • Gire firmemente el racor en dirección del cuerpo del accesorio, utilizando la llave Plasson (o similar) en los tamaños 40mm y mayores.



The nut should be closed tightly, however there is no need for the nut to actually meet the body shoulder.

Cierre el racor firmemente, aunque no es necesario cerrarlo hasta el tope.



* Lubrication and chamfering of the pipe end will ease insertion of the pipe (use silicone lubricant).

* A fin de facilitar la introducción es conveniente lubricar y biselar el tubo (con un lubricante que conforma las normas de aprobación de calidad del agua).

Installation Instructions for Compression Fittings

ASSEMBLY AS SIMPLE AS ABC...

For Fittings 75mm - 110mm / Para accesorios de 75mm - 110mm

Cut the pipe square, remove burrs

Undo the nut until 3-4 threads are visible.

Abra el racor hasta que se vean 3-4 roscas.
Corte el tubo en escuadra y quite las virutas del corte

A



Insert the pipe into the fitting until the stop.

Introduzca el tubo hasta que éste llegue a tocar perpendicularmente el cuerpo del accesorio.

B



Tighten the nut firmly with a Plasson wrench.

Cierre firmemente el racor con la llave Plasson.

C



Installation Instructions for Pipe Adaptors Conversion Sets

Universal Pipe Adaptors: Copper, Galvanised and Imperial U-PVC (Without Pullout Resistance)

Juegos de conversión de tubería: galvanizada, de cobre o de UPVC medidas imperiales (sin resistencia a la tracción)



Prepare pipe by ensuring that the end is free from grease and roughen the outer surface with wire wool or similar. Cut pipe end square. Remove nut from end of fitting and discard white split ring.



Push adaptor into fitting to the stop. Push and twist the pipe until it meets the internal stop.



Screw nut tightly towards the body of the fitting. Final tightening with a wrench is essential. The installation should be firmly anchored against end loading.

Se prepara el tubo asegurándose que el final del tubo no tenga grasa, y se lija el exterior con lana de alambre. Se hace un corte perpendicular al final del tubo. Se lleva el racor al final del accesorio y se quita el casquillo de apriete blanco.

Se empuja el adaptador en el tubo hasta el tope se empuja y se enrosca el tubo hasta que llegue al tope interior del accesorio.

Se aprieta firmemente el racor hacia el interior del accesorio. Es imprescindible que se apriete con una llave. Después, anclar firmemente la instalación.

Installation Instructions for Pipe Adaptors Conversion Sets

Adaptor Set for Copper (With Pullout Resistance) Juego de adaptadores para cobre (con resistencia a traccion)

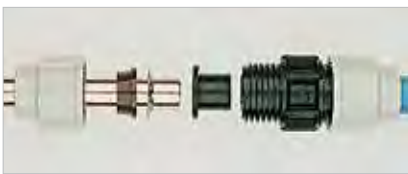

Cut pipe square. Remove burrs. Ensure pipe is free of scratches, dents and other imperfections. Remove nut from fitting and discard white split ring. Make a mark on the pipe to the depth of the rubber insert. Assemble nut, brown ring and stainless steel ring onto pipe in that order. Ensure the brown ring tapers towards the nut and the stainless steel ring towards the fitting body.



Push insert into fitting body fully up to the flange.



Push pipe end into body of fitting. Ensure to insert at least to the mark you have made. Push both the rings up to the insert flange and engage nut. Use a Plasson wrench for final tightening.

Corte el tubo a escuadra, limpie los restos del corte. Asegure que el tubo no este rayado, dentado, con virutas o con otras imperfecciones. Se lleva el racor hasta el final del accesorio y se quita el casquillo de apriete blanco. Se hace una marca en la superficie del tubo que es la profundidad del adaptador de goma. Se colocan el racor, el anillo marrón y el anillo de acero en el tubo, en este orden. Se comprueba que el anillo marrón se remata hacia la tuerca y el anillo de acero hacia el interior del accesorio.

Introducir el adaptador en el interior del accesorio hasta el final.

Introducir el tubo en el interior del accesorio. Comprobar que se introduce por lo menos hasta la marca hecha previamente. Se empujan ambos anillos hasta el adaptador de goma y se cierra firmemente el racor. Para apretar firmemente se debe utilizar la llave Plasson.

Installation Instructions for Pipe Adaptors Conversion Sets

Lead Pipe Adaptor Adaptadores para tuberías de plomo



Remove nut from fitting and discard white split ring. Mount nut on pipe followed by brown split ring and seal ring.



Push both components onto the pipe until the seal ring is 20mm from the end of pipe and touching the split ring.



Enter pipe into fitting body and tighten firmly with a wrench. (It is important that the pipe is not pushed fully to the stop in the fitting).

Note for lead pipe adaptors: This product seals on the outside diameter of the pipe and it is therefore important that the lead pipe is in good condition on the external part of the pipe where the seal is made. Variation in the lead piping sometimes results in oversized pipes. In these circumstances it may be preferable to use the white split ring provided with the fitting.

Se lleva el racor al final del accesorio y se quita el casquillo de apriete blanco. Se monta el racor al tubo seguido por el casquillo marrón y el anillo de goma.

Se empujan los dos componentes hasta que el anillo de goma esté a 20mm del final del tubo, y tocando el casquillo de apriete marrón.

Se introduce el tubo en el interior del accesorio y se aprieta firmemente con una llave (es importante que no se empuje el racor completamente hasta el final del accesorio).

Nota: El sellado con este producto se realiza con el diámetro exterior del tubo, y por lo tanto es importante que el exterior de la tubería de plomo esté en buen estado. Los variaciones en la tubería de plomo resultan a veces demasiado grandes. En estas circunstancias es preferible usar el casquillo de apriete que está previsto con el accesorio.

Installation Instructions for PLASS4 (Universal) Fittings



Instrucciones para la instalacion de accesorios plass4

Cut the pipe square and remove all burrs and sharp edges.

Select correct fitting according to the external diameter of the pipe.

Slide the PLASS4 fitting (universal side) onto the pipe, until it reaches the internal fins and a slight resistance is felt.

Do not force the pipe end past the fins.

Holding the PLASS4 body with a wrench, tighten the PLASS4 universal nut firmly with a wrench (size 35-50 tighten nut very firmly to approx. 90 NM)

Assemble the metric PE joint as per the standard fitting instructions.

Note: If reusing the fitting, ensure the metal teeth are located in the grip ring and pipe end does not pass the location fins in the body.

Corte el tubo a escuadra y elimine todas las virutas y cantos vivos.

Elija el accesorio apropiado de acuerdo con el diámetro del tubo.

Introduzca el accesorio PLASS4 (del lado Universal) en el tubo hasta que llegue al tope s sienta una ligera resistencia.

No fuerce el tubo y no pase las aletas.

Agarrando el cuerpo del PLASS4 con una llave apropiada, cierre firmamente el raccor con una llave (en las medidas 35-50 su raccor puede ser cerrado con un momento de 90 Nm). Arme la union de PE como en las instrucciones de los accesorios normales.

IMPORTANTE: no fuerce el tubo y pase el punto de resistencia. Puede danar el el accesorio.

Comience apretar la tuerca al cuerpo. el cierre final hagalo con una llave plasson o similar. Ensamble la junta metrica como las instrucciones de un accesorio estandard.

Installation Instructions for Copper Pipe Adaptor



Instrucciones para la instalacion de adaptor tubo de cobre

Cut the copper pipe square and remove all burrs and sharp edges.

Twist the copper pipe into the fitting* through the rubber o-ring to the pipe stop.

Tighten the nut firmly. Use a wrench for final tightening. The nut should be closed tightly, however there is no need for the nut to actually meet the body shoulder.

Assemble the metric PE joint as per the standard fitting instructions.

* Lubrication of the pipe end will ease the insertion (use silicone lubricant).

Note: If reused, the metal grip ring must be replaced with a new one.

Corte el tubo a escuadra y elimine todas las virutas y cantos vivos.

Introduzca girando* el tubo de cobre junto con el o-ring hasta el tope.

Apriete la tuerca firmemente. use una llave para el apriete final. La tuerca debe estar apretada hermeticamente. Sin embargo no es necesario que llegue hasta el borde del cuerpo.

Ensamble la junta metrica pe como un accesorio estandard.

* Para facilitar la introduccion utilice un lubricante a base de silicona.

NOTA: Si quiere reusar el accesorio debe reemplazar el agarre de metal por uno nuevo.



DELAR

US SWISS

The logo consists of a red square containing a white stylized 'E' symbol, followed by the word 'PLASSON' in white uppercase letters on a red rectangular background.

PLASSON

ELECTROFUSION FITTINGS

A close-up photograph of a metal fitting with a textured surface. The word 'PLASSON' is embossed in large, bold, uppercase letters across the middle of the fitting. Below it, the letters 'IC' and the number '0110' are also embossed.

PLASSON

IC 0110

Introduction Introducción

ElectroFusion System	3	Sistema ElectroFusión	3
Table of Contents	4 - 6	Indice	4 - 6
Fittings	7 - 38	Accesorios	7 - 38
Wastewater Line	39 - 44	Aguas residuales	39 - 44
Technical Specifications	46	Especificaciones técnicas	47
Controllers	48 - 51	Soldadoras automáticas	52 - 57
Installation Tools	58 - 62	Herramientas de instalación	58 - 62

PLASSON, a worldwide leader in fittings for polyethylene pipes for over 40 years, now offers a complete line of ElectroFusion products including: Plasson ElectroFusion fittings, tools and control boxes.

Plasson ElectroFusion products combine to offer a reliable smart-system solution featuring fully computerized control and monitoring.

PLASSON's customers benefit from the Company's quality products, expertise and worldwide first-rate service in water, gas distribution, Waste-Water Systems, Geothermal applications and industrial applications.

PLASSON, líder mundial en accesorios para tuberías de polietileno desde hace más de 40 años, presenta ahora una línea completa de productos de electrofusión, entre ellos: conectores, herramientas y soldadoras automáticas de ElectroFusión. La combinación de productos ElectroFusion de Plasson ofrece una solución inteligente y confiable que integra el control y la monitorización completamente computarizados.

Los clientes de PLASSON se benefician de los productos de calidad, la pericia y el excelente servicio mundial de la compañía en instalaciones de distribución de agua y gas, y aplicaciones industriales.

Subsidiary Companies Subsidiarias

Australia

Plasson Australia (PTY) Ltd.
E-mail: info@plasson.com.au
www.plasson.com.au

Brasil

Plasson Do Brasil
E-mail: plasson@plasson.com.br
www.plasson.com.br

France

Plasson France S.A.
E-mail: commercial@plassonfrance.fr
www.plasson.fr

Germany

Plasson GmbH
E-mail: info@plasson.de
www.plasson.de

Italy

Plasson Italia
E-mail: info@plasson.it
www.plasson.it

Poland

Plasson Polska Sp.z o.o.
E-mail: bs@plasson.pl
www.plasson.pl

South Africa

PLASSON SA Pty Ltd, t/a PPA
E-mail: support@ppa.co.za
www.ppa.co.za

Spain

Plasson Spain S.L.
E-mail: plasson@plasson.es
www.plasson.es

United Kingdom

Plasson UK Ltd.
E-mail: miron@plasson.co.uk
www.plasson.co.uk

USA

Plasson USA
E-mail: sales@plassonusa.com
www.plassonusa.com

Plasson ElectroFusion System

The Smart-System Solution You Can Depend On

Plasson ElectroFusion Fittings

Plasson fittings are specifically designed for reliable, high performance pipe joining and long system life. This automated system has been proven to be most economical due to the low potential for operator error.

Tools and Control Box

Plasson offers quality tools and control boxes allowing for easy installation. Plasson control boxes provide computerized ElectroFusion with minimal potential for operator error. The Plasson control boxes are the economical solution for reliable ElectroFusion.

The Smart Fuse System - Plasson ElectroFusion

All Plasson products combine to form the latest state-of-the-art high performance pipe joining solution. Plasson ElectroFusion fittings are part of a complete ElectroFusion Smart Fuse System. The entire ElectroFusion process is executed and fully monitored by the computerized control box. Everything is computer-controlled ensuring safe, dependable connections.

Plasson ElectroFusion fittings can be used with Plasson's computerized Smart Fuse System control box or with standard barcode systems. Each Plasson ElectroFusion fitting comes complete with a barcode.

Advantages

Stronger pipe joining - Plasson ElectroFusion quality fittings have long penetration depths and fusion zones which ensure high quality joints.

Most Economical - Economic benefits are a result of overall integrated system quality and innovation including the computerized Smart Fuse System which reduces the potential for operator error.

Plasson ElectroFusion Smart Fuse System Features

- **Superior Fitting Design**
increases joint integrity
- **Automatic Controller**
decreases potential operator error
- **Computerized Data Retrieval**
ensures quality control by Joint Data retrieval of measurements and records
- **Compatibility**
between Plasson ElectroFusion and other ElectroFusion systems through the computerized barcode system
- **Easy Installation**
using PLASSON's simple, practical tools
- **High Standards**
are ensured by the latest product testing methods

High Performance - Proven high performance in gas and water distribution and industrial applications.

Superior Service - Plasson provides unmatched service based on over 40 years in the field.

Sistema ElectroFusion de Plasson

La solución inteligente de confianza

Accesorios ElectroFusion de Plasson

Los accesorios ("fittings") de Plasson para tuberías han sido especialmente diseñados para asegurar conexiones fiables, de alto rendimiento y prolongada vida útil. Se ha comprobado que este sistema automatizado es el más económico, gracias a la escasa probabilidad de errores por parte del operador.

Herramientas y soldadora automática de ElectroFusión

Plasson ofrece herramientas de alta calidad y soldadoras automáticas que se instalan fácilmente. Las soldadoras, que proporcionan un proceso computarizado con mínima probabilidad de error humano, son la solución más económica para una electrofusión de máxima confianza.

ElectroFusion de Plasson - El sistema inteligente

Los productos de Plasson se combinan para ofrecer la solución más avanzada y rendidora en la conexión de tuberías. Los accesorios ElectroFusion de Plasson forman parte de un sistema completo e inteligente. La soldadora automática de ElectroFusión está a cargo de la ejecución y la monitorización del proceso. El sistema controlado por computadora asegura conexiones seguras y confiables.

Ventajas

Uniones más resistentes - Los accesorios de alta calidad ElectroFusion de Plasson tienen grandes profundidades de penetración y zonas de fusión que aseguran juntas muy resistentes.

La solución más económica - El beneficio económico es el resultado de la calidad y la innovación del sistema computarizado totalmente integrado, que reduce la probabilidad de error humano.

Características del sistema inteligente ElectroFusion de Plasson

- **Excelente diseño**
asegura la integridad de la conexión
- **Control automático**
reduce la probabilidad de error humano
- **Recuperación de datos**
calidad asegurada mediante la recuperación de datos de mediciones y registros
- **Compatibilidad**
con el sistema ElectroFusion de Plasson y otros sistemas de códigos de barras
- **Instalación sencilla**
mediante las herramientas prácticas y simples de PLASSON
- **Estándar elevado**
asegurado por los métodos de prueba de productos de última generación

Alta performance - Elevado rendimiento comprobado en instalaciones de distribución de gas y agua, y aplicaciones industriales.

Excelente servicio - Plasson le brinda un servicio inigualado, con su pericia y experiencia de más de 40 años en el terreno.

Fittings

490104/490103

Page 106 | Coupler
Enlace Recto



4901L4

Page 107 | Long Coupler
Enlace Largo



450104

Page 107 | Coupler (PN 25)
Enlace Recto (PN 25)



460104/460103

Page 108 | LightFit Coupler (PN 10)
Enlace LightFit (PN 10)



4601S3

Page 109 | Super LightFit (PN 6.4)



491104

Page 109 | Reducing Coupler
Enlace Reductor



491107

Page 110 | Spigot Reducer
Reductor Espiga



49009

Page 111 | Flex Restraint



494204

Page 111 | Monolithic End Cap
Tapón Monolítico



491204

Page 112 | End Cap
Tapón



491207

Page 113 | Spigot End Plug
Tapón Espiga



490404

Page 114 | Tee 90°
Enlace T 90°



492404

Page 114 | Two Outlets Reducing Tee
Enlace te Reductor con Salida Doble



491404

Page 115 | Reducing Tee
Enlace Reductor



499404

Page 116 | Flanged Tee
Enlace T Bridado



490504

Page 116 | Elbow 90°
Codo 90°



490604

Page 117 | Elbow 45°
Codo 45°



490804

Page 117 | Elbow 22.5°
Codo 22.5°



46060

Page 118 | LightFit Elbow 45°
Codo LightFit 45°



46330

Page 118 | LightFit Elbow 30°
Codo LightFit 30°



46370

Page 118 | LightFit Elbow 15°
Codo LightFit 15°



490904

Page 119 | Elbow 180°
Codo 180°



491904

Page 119 | Y Reducer
Y Reductor



491504

Page 120 | Duckfoot Elbow 90°
Codo 90° Empotrable



4915Q4

Page 120 | Duckfoot Elbow 90° with Outlet
Codo 90° Empotrable con
Toma de Servicio



4947C4

Page 121 | Adjustable Elbow
Codo Ajustable



4947D4

Page 121 | Adjustable Elbow One Sided
Codo Ajustable Enlace/
Espiga



496804

Page 122 | Balloon Saddle
Collarín Globo



498304

Page 122 | Monolithic Weld End Cap for
Ballon Saddle
Tapón Monolítico Soldable
para Collarín Globo



4958T

Page 123 | Saddle BSPP Female Outlet
Collarín BSPP Rosca
Hembra



495204

Page 123 | Repair Saddle
Toma de Reparación



493804

Page 124 | Transition Saddle
Collarín de Transición



495804

Page 125 | Branch Saddle
Collarín de Derivación



495804

Page 126 | Branch Saddle
Collarín de Derivación



495803

Page 126 | XL&XXL Branch Saddle
XL&XXL Collarín de
Derivación



4758W

Page 127 | LightFit Branch Saddle
Collarín de Derivación
LightFit



495904

Page 128 | Flange Branch Saddle
Collarín bridado



495204

Page 128 | Repair Saddle
Collarín de reparación



496304

Page 129-130 | Tapping Saddle
Toma de Servicio



4963P4

Page 131 | Tapping Saddle Parallel Outlet
Toma de Servicio Salida Parallel Outlet



498304

Page 132 | Welding Cap for Tapping Saddle
Tapón Soldable para toma de Servicio



436207

Page 132 | PE Ball Valve
Válvula de Bola PE



495404/4954S4

Page 133-134 | Tapping Valve
Toma de Servicio con Válvula



492104

Page 135 | Male Transition Coupler
Enlace de Transición Macho



493104

Page 135 | Female Transition Coupler
Enlace de Transición Hembra



492504

Page 136 | Male Transition Elbow 90°
Codo de Transición de 90° Macho



493504

Page 136 | Female Transition Elbow 90°
Codo de Transición de 90° Hembra



492604

Page 137 | Male Transition Elbow 45°
Codo de Transición de 45° Macho



493604

Page 137 | Female Transition Elbow 45°
Codo de Transición de 45° Hembra



494104

Page 138 | Female Free Nut Transition Coupler
Enlace de Transición Tuerca Libre Hembra



494504

Page 138 | Female Transition Elbow 90°
Codo de Transición de 90° Tuerca Libre, Hembra



494604

Page 139 | Female Free Nut Transition Elbow 45°
Codo de Transición de 45° Tuerca Libre Hembra



494404

Page 139 | Female Union Free Nut Transition Tee
Enlace T PE/Latón Tuerca Libre Hembra



497104

Page 140 | PE Male Transition Coupler
Enlace de Transición PE Macho



497504

Page 140

PE Male Transition Elbow 90°
Codo de Transición PE de 90°
Macho



497604

Page 141

PE Male Transition Elbow 45°
Codo de Transición PE de 45°
Macho



497704

Page 141

PE Cast Iron Flange
Transition Coupler
Enlace de Transición
Bridado - PE/Hierro Fundido



495704

Page 142

PE Cast Iron Spigot
Transition Coupler
Enlace de Transición Espiga
- PE/Hierro Fundido



490209

Page 142

Full Face Flange
Brida de Cara Plana



490207

Page 143

Stub Flange
Adaptador de Brida



09903

Page 144

Flange Backing Ring
Brida Revestida



Wastewater Line

475804

Page 146

Wastewater Adjustable
Saddle
Ramal para Aguas
Residuales



4758A4

Page 146

Wastewater Saddle 45° Inlet
110
Ramal 45° de Salida para
Aguas Residuales



4758V4

Page 147

Wastewater Saddle PVC/PP
Adaptor Inlet
Collarin Lightfit de transicion para
Aguas Residuales de PE A PP/PVC



4758S4

Page 147

Wastewater Saddle Spigot
Inlet
Collarin Lightfit para aguas
residuales con salida espiga



4747D4

Page 148

Wastewater Adjustable
Elbow One Sided
Codo Ajustable para Aguas
Residuales Enlace/Espiga



37020/477207

Page 148

Wastewater Manhole
Adaptor
Adaptador para Pozo de
Aguas Residuales



4701V4

Page 149

Wastewater PE to PVC
Adaptor
Adaptador Para PE A PVC



4747V4

Page 149

Wastewater Adjustable
Elbow PE to PVC
Codo Ajustable de
Transición de PE a PVC



470604

Page 150

Wastewater Elbow 45°
Codo 45° Para Aguas
Residuales



473304

Page 150

Wastewater Elbow 30°
Codo 30° Para Aguas
Residuales



473704

Page 150

Wastewater Elbow 15°
Codo 15° Para Aguas Residuales



Page 168

Key for Tapping Saddle
Llave para Toma de Servicio



Controllers

29143.0308S324

Page 155
Page 159

PolyCode (USB + Bluetooth)
PolyCode (USB)



Page 168

Rotational Scraper Tools
Raspatubos Giratorios



29143.F0318V112

Page 155
Page 160-161

PolyControl Plus
(USB + Bluetooth) V2.0
PolyControl Plus (USB) V2.0



Page 169

Plasson Scraper Tool for Pipe
Ends
Raspatubos Giratorio Plasson



29143.0307.103

Page 156
Page 162-163

Polymatic Plus
(USB + Bluetooth)
Polymatic Plus (USB)



Page 169

Pipe Cutter
Cortadores de Tubería



29143.0308T108

Page 156
Page 164-165

Tiny Data MF
(USB + Bluetooth)
Tiny Data MF (USB)



Page 169

Rotational Pipe Cutter (S-Type)
Cortador de Tubería Giratorio
(Tipo S)



29143.0307.000

Page 157
Page 166-167

Monomatic Data
(USB + Bluetooth)
Monomatic Data (USB)



Page 169

Rotational Pipe Cutters
Cortador de Tubería
Giratorio



Installation Tools

Page 168

Extension Key for Tapping Valve
Llave de Extensión para Toma
de Servicio Con Válvula



Page 170

Pipe Clamping Tools
Herramientas de Sujeción
de Tubos





Page 170

Squeeze - Off Tools
Prensatubos





Page 171	Rounding Rings Redondeadores	
----------	---------------------------------	---

Page 171	Detergents Detergentes	
----------	---------------------------	---

Page 171	Markers Marcadores	
----------	-----------------------	---

Page 172	Rounding Tool Redondeador hidráulico	
----------	---	--

Page 172	Tools for Wastewater Saddles Herramientas para enlaces para aguas residuales	
----------	---	---

Page 173	Rotational Scraper Tools Rascador giratorio para tuberías de PEAD	
----------	--	---

Page 173	Electrical Saddle Scraper Rascador eléctrico para tuberías de PEAD	
----------	---	---

Page 173	Core Drill Kit for Plasson-Saddle Outlet	
----------	--	---

Page 173	Drilling Machine	
----------	------------------	---

Page 173	Pressure Test Pump	
----------	--------------------	---

Page 174	Hot Tapping Tool	
----------	------------------	---

Page 174	Saddle Pressing Tool	
----------	----------------------	---

Page 174	Saddle Clamping Tool	
----------	----------------------	--

Page 174	Saddle Clamping Tool	
----------	----------------------	---

Page 175	Saddle Pressing and Clamping Tools Herramientas necesarias para la instalación de Collarines de derivación y transición de gran diámetro	
----------	---	---

Page 176	Core cutters- for each outlet size Brocas campana para cada diámetro	
----------	---	---

Coupler

490104

Enlace Recto



20mm up to 75mm

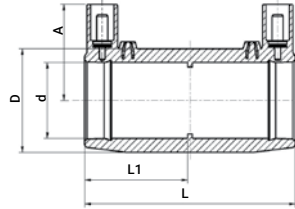

90mm up to 355mm

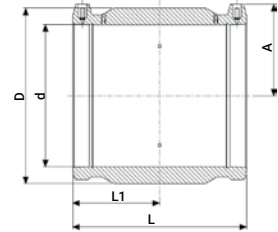

Product Code	Size d	L	L1	D	A	UC	W
490104016	16	71	34	35	39	480	58
490104020	20	76	37	31	34	440	50
490104025	25	82	40	36	37	360	40
490104032	32	88	42	44	42	256	63
490104040	40	97	47	56	46	200	97
490104050	50	101	49	67	51	132	147
490104063	63	117	57	82	57	72	230
490104075	75	126	61	98	64	60	340
490104090	90	148	73	112	71	38	566
490104110	110	163	80	135	81	23	718
490104125	125	173	85	157	87	18	1075
490104140	140	183	90	174	97	12	1295
490104160N	160	195	93	194	105	6	1550
490104180N	180	212	105	218	116	5	2112
490104200N	200	223	109	242	126	4	2785
490104225N	225	240	119	272	138	4	3900
490104250	250	251	123	301	156	2	4461
490104280	280	275	134	342	170	1	6440
490104315	315	282	139	387	184	1	8845
490104355	355	277	137	431	203	1	10200
490103400	400	293	145	485	231	1	13800

490103

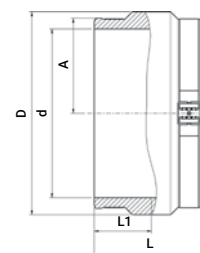

Product Code	Size d	L	L1	D	A	UC*	W
490103450	450	306	153	539	257	1	15800
490103500	500	340	170	603	283	1	20200
490103560	560	376	188	674	317	1	28000
490103630	630	418	209	759	356	1	39200
490103710	710	472	236	853	400	1	55700
490103800	800	500	250	955	450	1	87000

* Due to product size, cannot be packed in standard carton | * Cantidad óptima para embalaje en dos pallets apilados

Long Coupler

4901L4

Enlace Largo

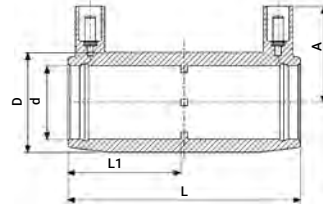

Product Code	Size d	L	L1	D	A	UC	W
4901L4032	32	104	50	44	43	272	84
4901L4040	40	121	59	56	46	128	135
4901L4050	50	139	68	68	51	96	215
4901L4063	63	166	81	82	57	48	317

Coupler (PN 25)

450104

Enlace Recto (PN 25)

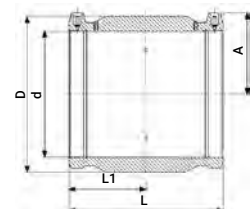
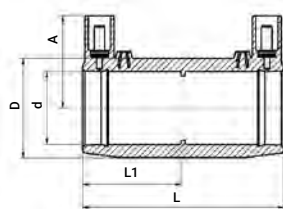

Product Code	Size d	L	L1	D	A	UC	W
450104050	50	100	49	68	52	132	147
450104063	63	118	57	82	58	72	230
450104075	75	126	62	97	65	60	339
450104090	90	148	73	117	69	38	571
450104110	110	163	80	140	79	23	835
450104125	125	173	85	157	87	18	1075
450104160	160	198	97	198	105	6	1780
450104180	180	212	104	224	114	4	2449
450104200	200	223	110	249	126	4	3295
450104225	225	240	118	280	140	4	4366
450104250	250	256	127	310	155	2	5507
450104280	280	274	135	341	166	1	6369
450104315	315	284	140	381	184	1	8884

LightFit Coupler (PN10)

460104

Enlace LightFit (PN10)

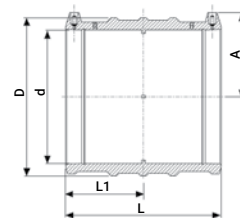

Product Code	Size d	L	L1	D	A	UC	W
460104040	40	90	43	56	47	200	96
460104050	50	100	49	68	52	132	98
460104063	63	118	57	77	57	112	157
460104075	75	126	61	90	63	60	215
460104090	90	148	72	108	69	44	360
460104110	110	163	80	131	79	25	540
460104125	125	173	85	149	87	20	740
460104140	140	182	89	167	94	12	970
460104160	160	198	97	193	104	6	1320
460104180	180	212	104	215	114	5	1650
460104200	200	232	114	235	127	4	2100
460104225	225	240	118	264	141	4	2825
460104250	250	256	126	293	155	2	3728
460104280	280	275	135	332	166	1	4850
460104315	315	284	140	374	184	1	6950
460104355	355	280	138	421	204	1	7980
460104400	400	296	146	474	227	1	11893

460103*

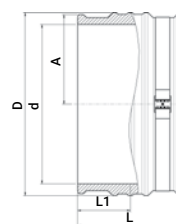

Product Code	Size d	L	L1	D	A	UC*	W
460103450	450**	310	155	518	255	1	11700
460103500	500**	340	170	576	283	1	16000
460103560	560	376	188	645	317	1	21500
460103630	630	418	209	726	356	1	30820
460103710	710	472	236	817	400	1	43100
460103800	800	500	250	913	450	1	57300
460103900	900	500	250	1031	500	1	70000

* Due to product size, cannot be packed in standard carton | * Cantidad óptima para embalaje en dos pallets apilados

** Without Straps | ** Sin correas

Super LightFit (PN 6.4)

4601S3

Super LightFit (PN 6.4)

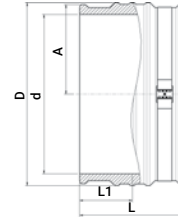

Product Code	Size d	L	L1	D	A	UC	W
4601S3500	500	300	150	550	272	1	11800
4601S3560	560	310	155	620	310	1	15300
4601S3630	630	320	160	693	346	1	18200
4601S3710	710	380	190	775	388	—	—
4601S3800	800	400	200	876	438	1	34700

Reducing Coupler

491104

Enlace Reductor

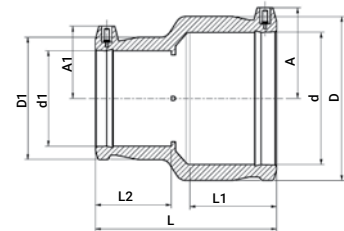
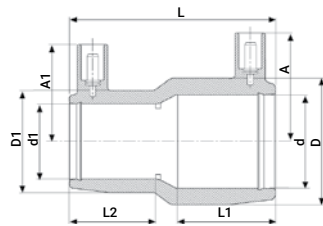

20x16mm up to 110x90mm

125x90mm up to 180x125mm

Product Code	Size dx d1	L	A	A1	L1	L2	D	D1	UC	W
491104020016	20 x 16	71	39	39	35	35	36	36	480	54
491104025020	25 x 20	71	39	39	35	35	36	36	480	46
491104032020	32 x 20	81	43	37	40	35	45	32	360	59
491104032025	32 x 25	81	43	39	40	35	45	36	360	56
491104040025	40 x 25	90	47	38	44	40	56	37	200	85
491104040032	40 x 32	90	47	43	44	40	56	44	160	92
491104050025	50 x 25	100	52	41	49	41	68	37	160	118
491104050032	50 x 32	100	52	45	49	40	68	45	128	123
491104050040	50 x 40	100	52	48	49	44	68	56	128	135
491104063032	63 x 32	119	59	45	57	40	82	45	96	179
491104063040	63 x 40	119	59	49	57	44	82	56	96	192
491104063050	63 x 50	119	59	54	57	49	82	68	80	223
491104075063	75 x 63	126	66	59	66	57	98	82	65	314
491104090050	90 x 50	143	78	53	71	49	116	69	54	430
491104090063	90 x 63	143	78	61	71	57	116	82	44	460
491104090075	90 x 75	143	78	67	71	61	116	98	41	480
491104110063	110 x 63	161	84	61	78	57	139	82	32	639
491104110090	110 x 90	161	84	74	78	72	139	116	23	740
491104125090	125 x 90	171	88	70	85	72	158	116	18	1019
491104125110	125 x 110	171	88	80	85	78	158	141	18	1025
491104160090	160 x 90	193	105	69	94	72	199	116	12	1440
491104160110	160 x 110	193	105	80	94	81	199	141	12	1520
491104160125	160 x 125	195	105	89	94	85	199	158	6	1570
491104180125	180 x 125	212	116	87	103	85	222	158	6	2060

Spigot Reducer

491107

Reductor Espiga

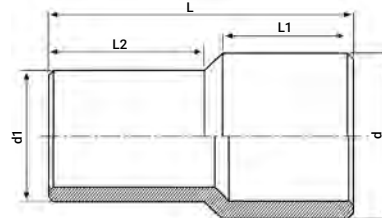

Product Code	Size dxd1	L	L1	L2	UC	W
491107032025	32 x 25	104	50	48	240	30
491107040032	40 x 32	123	59	56	240	90
491107050032	50 x 32	129	59	56	160	80
491107050040	50 x 40	131	59	60	264	100
491107063032	63 x 32	131	59	58	144	110
491107063040	63 x 40	132	59	58	144	120
491107063050	63 x 50	132	60	60	128	125
491107075040	75 x 40	145	71	60	96	167
491107075050	75 x 50	145	71	59	96	180
491107075063	75 x 63	151	71	65	72	210
491107090050	90 x 50	156	81	59	56	280
491107090063	90 x 63	160	80	65	48	300
491107090075	90 x 75	166	80	71	40	320
491107110063	110 x 63	167	83	66	36	450
491107110075	110 x 75	169	83	72	36	460
491107110090	110 x 90	178	83	80	28	510
491107125090	125 x 90	186	90	81	24	655
491107125110	125 x 110	188	90	84	18	730
491107140090	140 x 90	208	95	80	16	850
491107140110	140 x 110	195	95	83	16	850
491107140125	140 x 125	199	95	89	12	950
491107160110	160 x 110	219	101	84	10	1150
491107160125	160 x 125	206	101	88	16	1170
491107160140	160 x 140	211	101	94	10	1270
491107180125	180 x 125	221	107	89	10	1500
491107180140	180 x 140	224	107	95	10	1600
491107180160	180 x 160	225	107	100	8	1750
491107200140	200 x 140	229	114	93	8	2200
491107200160	200 x 160	233	115	100	6	2180
491107200180	200 x 180	241	116	106	5	2350
491107225160	225 x 160	295	132	123	—	3120
491107225180	225 x 180	285	130	118	—	3320
491107225200	225 x 200	272	126	120	—	3255
491107250160	250 x 160	308	149	100	—	3705
491107250180	250 x 180	316	151	105	—	4050
491107250200	250 x 200	324	151	116	—	4380
491107250225	250 x 225	330	155	122	—	4850
491107280200	280 x 200	345	140	116	—	5850
491107280225	280 x 225	335	142	122	—	6085
491107280250	280 x 250	340	139	135	—	6540
491107315225	315 x 225	365	150	125	—	7900
491107315250	315 x 250	365	147	134	—	8100
491107315280	315 x 280	365	150	145	—	8800
491107355250	355 x 250	390	164	136	—	9100
491107355280	355 x 280	390	164	139	—	9500
491107355315	355 x 315	390	164	150	—	9890
491107400280	400 x 280	415	179	139	—	10420
491107400315	400 x 315	415	179	150	—	11130
491107400355	400 x 355	420	179	164	—	11580

Maximum Pressure: PN 16 (cold water) | Presión Máxima: PN 16 (agua fría)

Additional dimensions and pressure rated spigots are available upon request

Los tamaños y presiones no enunciados en la tabla están disponibles a pedido

Flex Restraint

49009

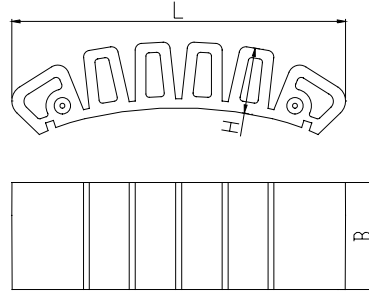

Product Code	Size	L	H	B	UC	W
49009999	160-1600	202	40	65	60	251

Flex Restraint

49009

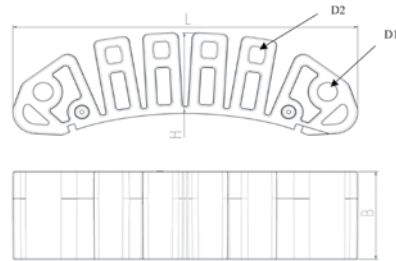

Product Code	Size	L	H	B	UC	W
49009998	160-1600	237	60	65	-	-

Monolithic End Cap

494204

Tapón Monolítico

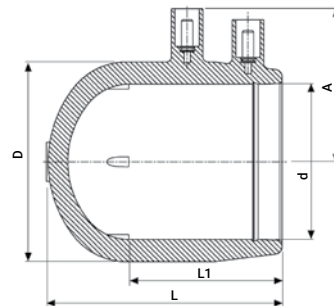

Product Code	Size d	L	L1	D	A	UC	W
494204032	32	63	44	44	46	432	50
494204040	40	70	48	55	51	256	75
494204050	50	82	55	68	56	192	122
494204063	63	95	62	81	62	96	181

End Cap

491204

Tapón

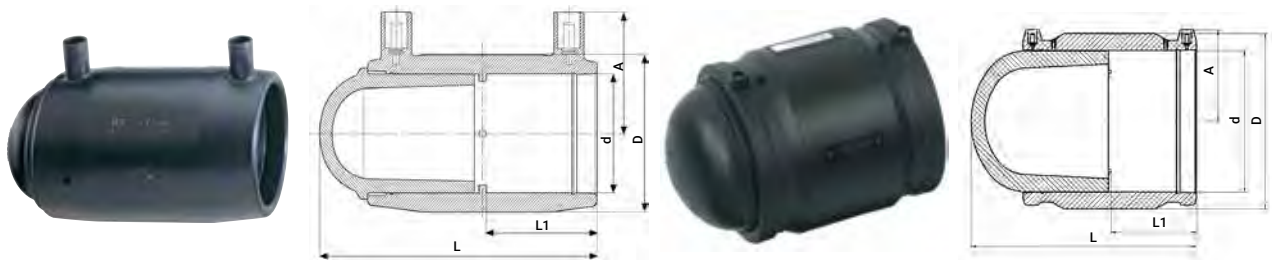

20mm up to 75mm

90mm up to 315mm

Product Code	Size d	L	L1	D	A	UC	W
491204020	20	84	37	31	34	400	55
491204025	25	92	40	36	37	400	50
491204032	32	103	42	44	42	300	76
491204040	40	114	47	56	46	160	130
491204050	50	121	49	67	51	120	204
491204063	63	142	57	82	57	72	327
491204075	75	156	61	98	64	48	499
491204090	90	183	73	117	70	30	820
491204110	110	206	78	140	81	20	1259
491204125	125	222	85	157	87	15	1702
491204140	140	237	90	174	97	10	2346
491204160	160	261	93	194	105	6	2990
491204180	180	283	105	218	116	5	4159
491204200	200	289	109	242	126	4	5260
491204225	225	318	119	272	138	2	7260
491204250	250	344	123	311	156	1	8381
491204280	280	396	134	340	170	1	11740
491204315	315	405	139	387	184	2	16045

* Less than 1 per master, meaning per large master

Spigot End Plug

491207

Tapón Espiga

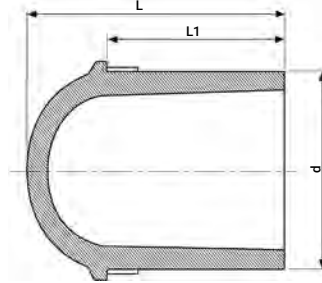

Product Code	Size d	L	L1	UC	W
491207020	20	43	35	2000	8
491207025	25	46	36	1600	10
491207032	32	52	39	960	17
491207040	40	59	43	560	29
491207050	50	68	48	352	52
491207063	63	81	57	192	94
491207075	75	90	60	132	149
491207090	90	105	70	72	250
491207110	110	121	78	57	430
491207125	125	131	82	36	596
491207140	140	142	87	25	797
491207160	160	157	94	18	1149
491207180	180	172	101	14	1600
491207200	200	178	112	10	2089
491207225	225	196	120	6	2800
491207250	250	216	130	4	3920
491207280	280	257	162	3	5300
491207315	315	262	167	2	7200

Tee 90°

490404

Enlace T 90°

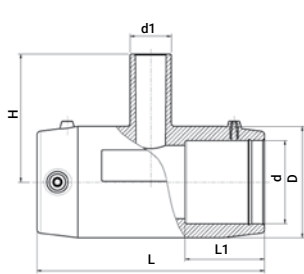

20mm up to 75mm

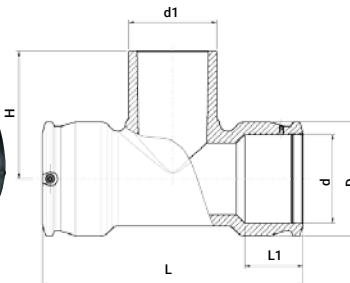

90mm up to 250mm

Product Code	Size dxd1xd	L	L1	D	H	A	UC	W
490404020	20 x 20 x 20	96	37	33	60	39	260	60
490404025	25 x 25 x 25	103	39	44	66	43	168	109
490404032	32 x 32 x 32	104	39	44	74	43	144	96
490404040	40 x 40 x 40	120	43	56	90	47	96	165
490404050	50 x 50 x 50	139	48	68	102	52	56	257
490404063	63 x 63 x 63	167	58	82	119	58	32	417
490404075	75 x 75 x 75	196	63	96	129	62	26	638
490404090	90 x 90 x 90	294	71	113	137	71	15	1090
490404110	110 x 110 x 110	326	71	143	160	81	8	1955
490404125	125 x 125 x 125	382	86	165	177	88	4	2950
490404160	160 x 160 x 160	440	86	208	206	106	3	4700
490404180	180 x 180 x 180	422	106	245	250	116	1	7200
490404200	200 x 200 x 200	451	114	261	265	125	1	8650
490404225	225 x 225 x 225	494	122	293	290	140	1	11860
490404250	250 x 250 x 250	538	129	326	315	152	1	16250

Two Outlets Reducing Tee

492404

Enlace te Reductor con Salida Doble

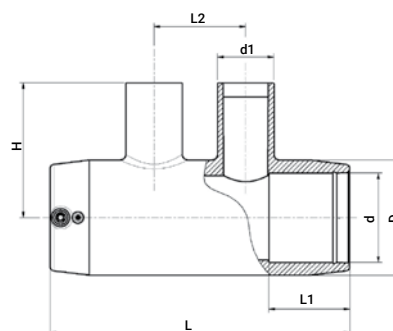

Product Code	Size dxd1 - d1xd	L	L1	L2	D	H	A	UC	W
492404040025	40 x 25 - 25 x 40	176	46	57	56	72	46	96	229
492404040032	40 x 32 - 32 x 40	176	46	57	56	76	46	75	233
492404050025	50 x 25 - 25 x 50	195	49	65	68	79	51	56	342
492404050032	50 x 32 - 32 x 50	195	49	65	68	83	51	58	336
492404050040	50 x 40 - 40 x 50	195	49	65	68	89	51	52	352
492404063025	63 x 25 - 25 x 63	213	58	65	82	86	57	42	457
492404063032	63 x 32 - 32 x 63	213	58	65	82	90	57	40	464
492404063040	63 x 40 - 40 x 63	213	58	65	82	96	57	36	480

Reducing Tee

491404

Enlace T Reductor

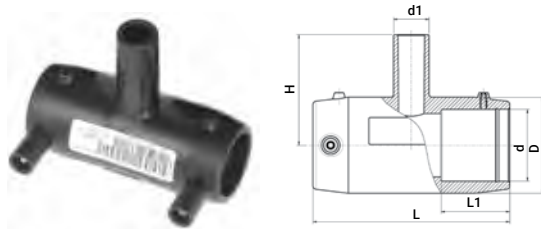

20mm up to 75mm

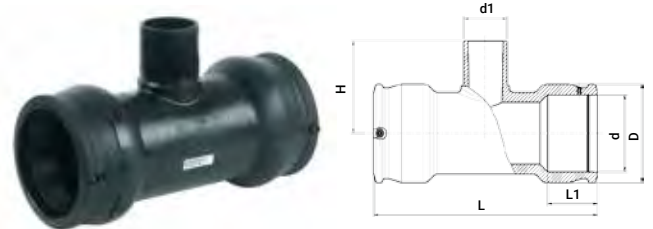

90mm up to 250mm

Product Code	Size dxd1xd	L	L1	D	H	A	UC	W
491404025020	25 x 20 x 25	104	39	44	66	43	168	108
491404025032	25 x 32 x 25	104	39	44	74	43	168	116
491404032020	32 x 20 x 32	104	39	44	66	43	144	89
491404032025	32 x 25 x 32	104	39	44	66	43	144	91
491404040020	40 x 20 x 40	120	43	56	72	47	96	151
491404040025	40 x 25 x 40	120	43	56	72	47	96	150
491404040032	40 x 32 x 40	120	43	56	75	47	96	152
491404050020	50 x 20 x 50	139	48	68	78	52	64	224
491404050025	50 x 25 x 50	139	48	68	78	52	64	225
491404050032	50 x 32 x 50	139	48	68	86	52	64	228
491404050040	50 x 40 x 50	139	48	68	90	52	64	237
491404063020	63 x 20 x 63	167	49	82	85	58	40	348
491404063032	63 x 32 x 63	167	58	82	93	58	32	353
491404063040	63 x 40 x 63	167	58	82	104	58	32	365
491404063050	63 x 50 x 63	167	58	82	109	58	32	381
491404075063	75 x 63 x 75	196	63	96	122	62	26	607
491404090063	90 x 63 x 90	294	68	113	124	71	15	1050
491404110063	110 x 63 x 110	326	71	143	134	81	9	1715
491404110090	110 x 90 x 110	326	71	143	147	81	8	1815
491404125090	125 x 90 x 125	382	86	165	161	88	5	2805
491404125110	125 x 110 x 125	382	86	165	173	88	5	2859
491404160090	160 x 90 x 160	440	86	208	180	106	3	4450
491404160110	160 x 110 x 160	440	86	208	193	106	3	4450
491404160125	160 x 125 x 160	440	86	208	198	106	3	4470
491404180090	180 x 90 x 180	422	106	245	200	116	2	6090
491404180110	180 x 110 x 180	422	106	245	219	116	2	6270
491404180125	180 x 125 x 180	422	106	245	225	116	2	6410
491404180140	180 x 140 x 180	422	106	245	237	116	1	6610
491404180160	180 x 160 x 180	422	106	245	250	116	1	6950
491404200090	200 x 90 x 200	451	114	261	205	125	2	7140
491404200110	200 x 110 x 200	451	114	261	210	125	2	7235
491404200160	200 x 160 x 200	451	114	261	400	125	—	—
491404225090	225 x 90 x 225	494	122	293	220	140	1	9900
491404225110	225 x 110 x 225	494	122	293	225	140	1	10000
491404225160	225 x 160 x 225	494	122	293	430	140	—	—
491404250090	250 x 90 x 250	538	129	326	235	152	1	13350
491404250110	250 x 110 x 250	538	129	326	240	152	1	13400
491404250160	250 x 160 x 250	538	129	326	445	152	—	—

* This size enlarges | * Esta media agranda

Flanged Tee

499404

Enlace T Bridado

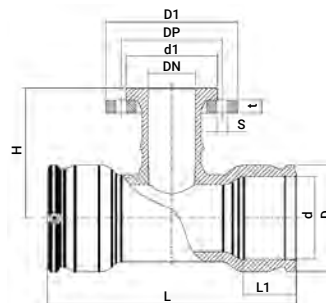

Product Code	Size d x DN x d	L	L1	D	H	A	D1	t	s	d1	DP	UC	W
499404090080	90 x 80 x 90	294	71	113	165	71	200	20	8 x 18	138	160	8	2835
499404110080	110 x 80 x 110	326	71	143	181	81	200	20	8 x 18	138	160	6	3560
499404110100	110 x 100 x 110	326	71	143	181	81	220	22	8 x 18	158	180	6	4240
499404125080	125 x 80 x 125	382	86	165	190	88	200	20	8 x 18	138	160	4	4550
499404125100	125 x 100 x 125	382	86	165	190	88	220	22	8 x 18	158	180	3	5180
499404160080	160 x 80 x 160	440	86	208	210	106	200	20	8 x 18	138	160	3	6245
499404160100	160 x 100 x 160	440	86	208	210	106	220	22	8 x 18	158	180	3	6785
499404180080	180 x 80 x 180	422	106	245	225	116	200	20	8 x 18	138	160	2	7745
499404180100	180 x 100 x 180	422	106	245	225	116	220	22	8 x 18	158	180	1	8550
499404200080	200 x 80 x 200	451	114	261	240	125	200	20	8 x 18	138	160	1	8510
499404200100	200 x 100 x 200	451	114	261	245	125	220	22	8 x 18	158	180	1	9230
499404225080	225 x 80 x 225	494	122	293	255	140	200	20	8 x 18	138	160	1	11240
499404225100	225 x 100 x 225	494	122	293	260	140	220	22	8 x 18	158	180	1	11900
499404250080	250 x 80 x 250	538	129	326	270	152	200	20	8 x 18	138	160	1	14750
499404250100	250 x 100 x 250	538	129	326	275	152	220	22	8 x 18	158	180	1	15400

Elbow 90°

490504

Codo 90°

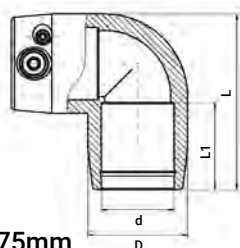

20mm up to 75mm

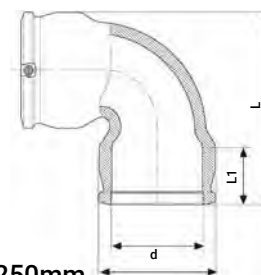

90mm up to 250mm

Product Code	Size d	L	L1	D	A	UC	W
490504020	20	66	35	36	38	320	65
490504025	25	66	37	36	38	320	52
490504032	32	83	40	44	43	192	85
490504040	40	92	44	55	47	120	137
490504050	50	108	48	68	52	72	211
490504063	63	131	57	81	59	40	320
490504075	75	158	69	97	62	33	527
490504090	90	213	78	113	69	19	875
490504110	110	243	79	143	79	9	1519
490504125	125	271	100	165	89	7	2424
490504140	140	309	93	183	94	4	3024
490504160	160	323	87	209	106	3	3990
490504180	180	412	105	244	115	2	7590
490504200	200	449	112	262	124	1	8670
490504225	225	498	121	295	140	1	12200
490504250	250	550	130	327	152	1	13500

Elbow 45°

490604

Codo 45°



32mm up to 75mm

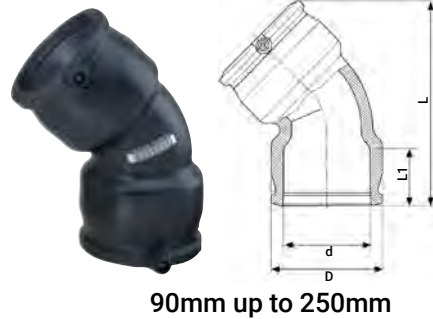

90mm up to 250mm

Product Code	Size d	L	L1	D	A	UC	W
490604032	32	95	39	45	43	240	75
490604040	40	108	42	55	46	160	117
490604050	50	125	49	68	51	96	181
490604063	63	148	57	81	59	60	263
490604075	75	180	71	96	62	40	426
490604090	90	243	75	112	69	22	759
490604110	110	271	81	143	78	12	1269
490604125	125	304	86	165	88	8	2030
490604140	140	342	92	182	95	5	2471
490604160	160	350	95	209	105	4	3990
490604180	180	434	105	244	114	2	6150
490604200	200	472	112	261	125	1	7050
490604225	225	520	120	294	140	1	9800
490604250	250	571	129	326	151	1	13400

Elbow 22.5°

490804

Codo 22.5°

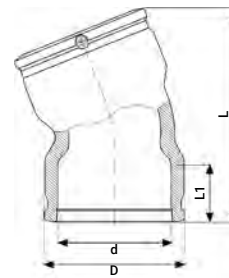

Product Code	Size d	L	L1	D	A	UC	W
490804090	90	214	72	113	71	26	665
490804110	110	232	71	143	81	14	1087
490804125	125	274	86	165	88	8	1850
490804160	160	302	86	209	106	5	2930
490804180	180	391	105	244	115	2	5360

LightFit Elbow 45°

46060

Codo LightFit 45°

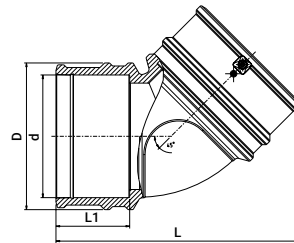

Product Code	Size d	L	L1	D	A	UC	W
460604160	160	323	98	193	106	4	1976

LightFit Elbow 30°

46330

Codo LightFit 30°

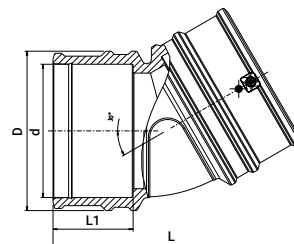

Product Code	Size d	L	L1	D	A	UC	W
463304160	160	300	98	193	106	4	1798

LightFit Elbow 15°

46370

Codo LightFit 15°

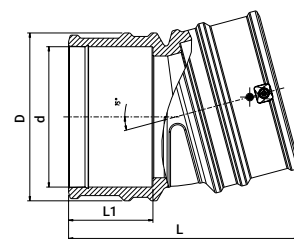

Product Code	Size d	L	L1	D	A	UC	W
463704160	160	265	98	193	106	6	1728

Elbow 180°

490904

Codo 180°

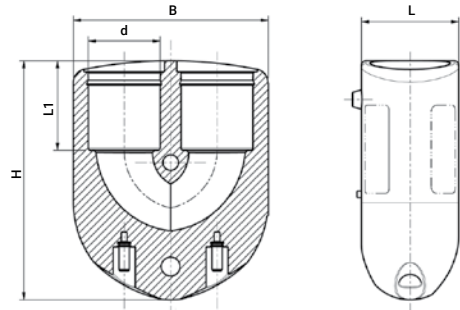

Product Code	Size d	L	L1	H	B	UC	W
490904025	25	38	38	99	72	216	163
490904032	32	44	41	108	88	144	216
490904040	40	53	48	123	106	80	323

Y Reducer

491904

Y Reductor

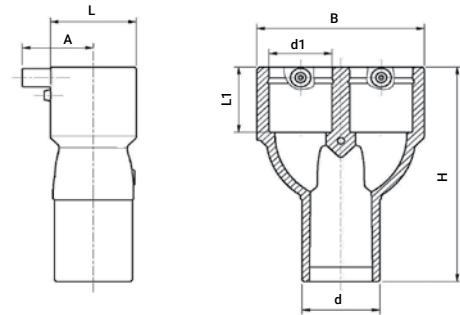

Product Code	Size d x d1 x d1	L	L1	B	A	H	UC	W
491904032025	32 x 25 x 25	36	40	70	38	119	200	97
491904040032	40 x 32 x 32	45	43	87	42	133	120	151
491904050040	50 x 40 x 40	56	46	108	46	151	72	242

Duckfoot Elbow 90°

491504

Codo 90° Empotrable

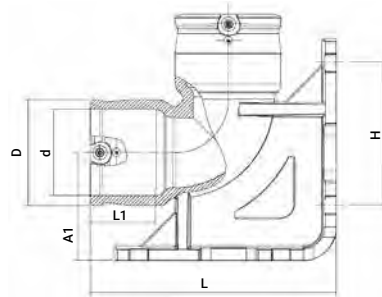

Product Code	Size d	L	L1	D	A	A1	H	UC	W
491504090	90	261	69	112	71	115	146	5	2260

Duckfoot Elbow 90° With Outlet

4915Q4

Codo 90° Emportable con toma de servicio

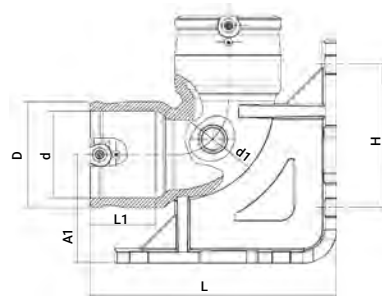

Product Code	Size d x d1	L	L1	D	A	A1	H	UC	W
4915Q4090032	90 x 32	261	69	112	71	115	146	5	2265

Adjustable Elbow

4947C4

Codo Ajustable

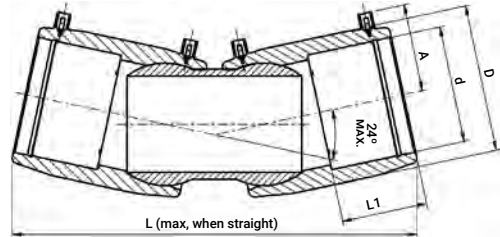

Product Code	Size d	L	L1	D	A	UC	W
4947C4090	90	341	72	116	77	12	1450
4947C4110	110	362	80	140	83	8	2030
4947C4125	125	382	85	157	95	8	2630
4947C4160	160	456	92	200	114	3	4510
4947C4180	180	511	104	224	128	2	7490
4947C4200	200	512	104	250	125	2	9733
4947C4225	225	600	105	282	141	2	13230
4947C4250	250	644	123	312	156	1	16775

Adjustable Elbow One Sided

4947D4

Codo Ajustable Enlace/Espiga

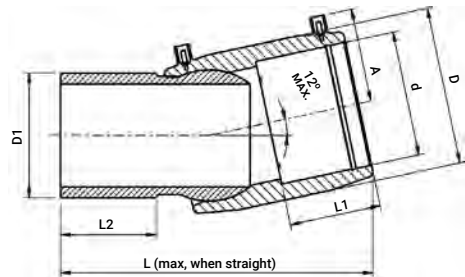

Product Code	Size d x D1	L	L1	L2	D	A	UC	W
4947D4090	90 x 90	258	72	82	116	77	20	940
4947D4110	110 x 110	276	85	85	140	83	12	1290
4947D4125	125 x 125	292	90	90	157	95	12	1740
4947D4160	160 x 160	335	100	100	200	114	4	3150
4947D4180	180 x 180	365	138	138	223	128	3	4210
4947D4200	200 x 200	370	104	116	250	125	2	6172
4947D4225	225 x 225	426	105	124	282	141	2	8340
4947D4250	250 x 250	455	123	134	312	156	1	10800

Balloon Saddle

496804

Collarín Globo

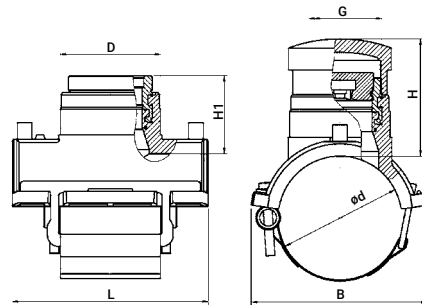

Product Code	Size d x G	B	H	H1	D	L	UC	W
496804090025	90 x 2.1/2"	142	105	70	90	176	10	1961
496804110025	110 x 2.1/2"	160	105	70	90	176	10	1973
496804125025	125 x 2.1/2"	169	105	70	90	176	10	1981
496804140025	140 x 2.1/2"	174	105	70	90	176	10	2000
496804160025	160 x 2.1/2"	176	105	70	90	176	10	1984
496804180025	180 x 2.1/2"	182	105	70	90	176	10	1997
496804200025	200 x 2.1/2"	202	105	70	90	176	10	1991
496804225025	225 x 2.1/2"	227	105	70	90	176	10	2003
496804250025	250 x 2.1/2"	252	105	70	90	176	10	2010

Monolithic Weld End Cap for Balloon Saddle

498304

Tapón Monolítico Soldable para collarín globo

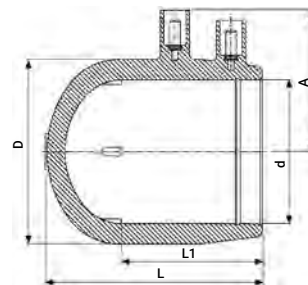

Product Code	Size d	L	L1	D	A	UC	W
498304090	90	123	77	117	77	55	479

Saddle BSPP Female Outlet

4958T4

Collarín BSPP Rosca Hembra

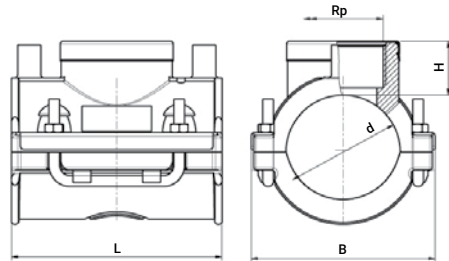

Product Code	Size d x Rp	B	H	L	UC	W
4958T4063007	63 x 3/4"	100	30	118	60	390
4958T4063010	63 x 1"	100	30	118	60	390
4958T4063013	63 x 1.1/4"	100	30	118	60	400
4958T4063015	63 x 1.1/2"	100	30	118	60	400
4958T4090010	90 x 1"	126	30	118	36	520
4958T4090013	90 x 1.1/4"	126	30	118	36	530
4958T4090015	90 x 1.1/2"	126	30	118	—	525

Repair Saddle

495204

Toma de Reparación

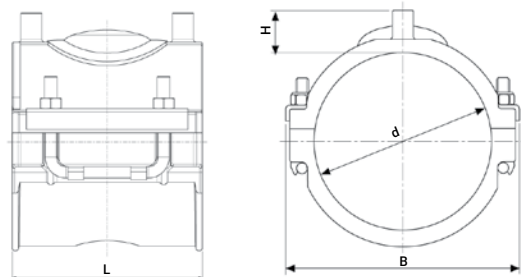

Product Code	Size d	B	H	L	UC	W
495204063	63	100	29	118	72	378
495204075	75	117	29	118	48	405
495204090	90	126	29	118	40	504
495204110	110	148	29	118	32	573
495204125	125	162	29	118	24	620
495204140	140	180	29	118	24	660
495204160	160	199	29	118	24	731
495204180	180	219	29	118	16	759

Transition Saddle

493804

Collarín de Transición



63mm up to 180mm
Outlets 1¼" and 1½"



90mm up to 250mm
Outlet 2"

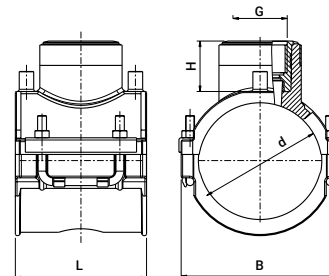

Product Code	Size d x G	B	H	L	UC	W
493804063013	63 x 1.1/4"	100	53	118	48	612
493804075013	75 x 1.1/4"	117	53	118	40	656
493804090015	90 x 1.1/2"	121	53	118	16	930
493804090020	90 x 2"	142	76	176	14	1436
493804110015	110 x 1.1/2"	142	53	118	12	1000
493804110020	110 x 2"	158	76	176	12	1500
493804125015	125 x 1.1/2"	158	53	118	12	1049
493804125020	125 x 2"	166	76	176	12	1510
493804140015	140 x 1.1/2"	175	53	118	10	1072
493804140020	140 x 2"	174	76	176	10	1520
493804160015	160 x 1.1/2"	196	53	118	8	1163
493804160020	160 x 2"	176	76	176	10	1540
493804180015	180 x 1.1/2"	216	53	118	6	1200
493804180020	180 x 2"	182	76	176	10	1500
493804200020	200 x 2"	202	76	176	10	1575
493804225020	225 x 2"	227	76	176	10	1570
493804250020	250 x 2"	252	76	176	10	1546

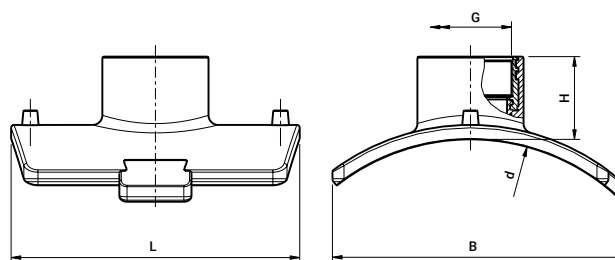
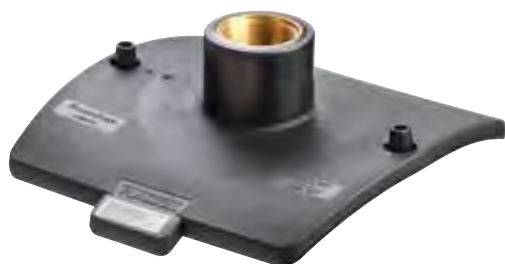

Product Code	Size d x G	B	H	L	UC	W
493804400020	250-400 x 2"	305	77	306	8	1975
493804710020	450-800 x 2"	315	77	306	8	1960

* See dedicated tools on page 175 | * Ver herramientas necesarias en pag. 175

Branch Saddle

495804

Collarín de Derivación



63mm up to 180mm
Outlets 32mm to 63mm



200mm up to 315mm
and all sizes with Outlet 90mm

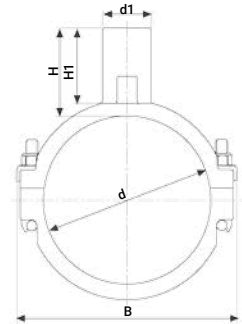
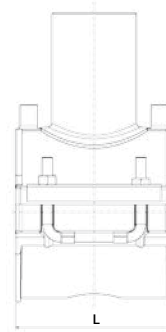

Product Code	Size d x d1	B	H	H1	L	Max Cutting Dia	UC	W
495804063032	63 x 32	100	59	49	118	23	56	394
495804063040	63 x 40	100	78	66	118	29.5	40	400
495804063050	63 x 50	100	93	82	118	37.5	40	430
495804063063	63 x 63	100	94	85	118	45	40	462
495804075032	75 x 32	117	59	49	118	23	48	431
495804075040	75 x 40	117	78	66	118	29.5	36	451
495804075050	75 x 50	117	93	82	118	37.5	32	465
495804075063	75 x 63	117	94	85	118	45	32	522
495804090032	90 x 32	126	59	49	118	23	32	519
495804090040	90 x 40	126	78	68	118	29.5	32	529
495804090050	90 x 50	126	93	82	118	37.5	32	550
495804090063	90 x 63	126	94	85	118	45	24	608
495804090090	90 x 90	139	105	90	176	66	15	934
495804110032	110 x 32	148	59	49	118	23	24	585
495804110040	110 x 40	148	78	68	118	29.5	24	598
495804110050	110 x 50	148	93	82	118	37.5	20	629
495804110063	110 x 63	148	94	85	118	45	20	658
495804110090	110 x 90	162	105	90	176	68	18	948
495804125032	125 x 32	162	59	49	118	23	24	620
495804125040	125 x 40	162	78	68	118	29.5	20	613
495804125050	125 x 50	162	93	82	118	37.5	20	690
495804125063	125 x 63	162	94	85	118	45	16	721
495804125090	125 x 90	169	105	90	176	68	18	953
495804140032	140 x 32	180	59	49	118	23	24	689
495804140040	140 x 40	180	78	68	118	29.5	16	664
495804140050	140 x 50	180	93	82	118	37.5	16	721
495804140063	140 x 63	180	94	85	118	45	16	736
495804140090	140 x 90	174	105	90	176	68	16	965
495804160032	160 x 32	200	59	49	118	23	16	708
495804160040	160 x 40	200	78	68	118	29.5	16	722
495804160050	160 x 50	200	93	82	118	37.5	16	787
495804160063	160 x 63	200	94	85	118	45	16	825
495804160090	160 x 90	176	105	90	176	68	16	956
495804180032	180 x 32	219	59	49	118	23	16	800
495804180040	180 x 40	219	78	68	118	29.5	12	800
495804180050	180 x 50	219	93	82	118	37.5	12	828
495804180063	180 x 63	219	94	85	118	45	12	886
495804180090	180 x 90	182	105	90	176	68	15	976
495804200063	200 x 63	202	102	85	176	47	15	862
495804200090	200 x 90	202	105	90	176	68	15	900
495804225063	225 x 63	227	102	85	176	47	15	930
495804225090	225 x 90	227	105	90	176	68	15	983
495804250063	250 x 63	252	102	85	176	47	15	970
495804250090	250 x 90	252	105	90	176	68	15	990
495804280090	280 x 90	282	105	90	176	68	15	990
495804315090	315 x 90	317	105	90	176	68	15	990

Branch Saddle

495804

Collarín de Derivación

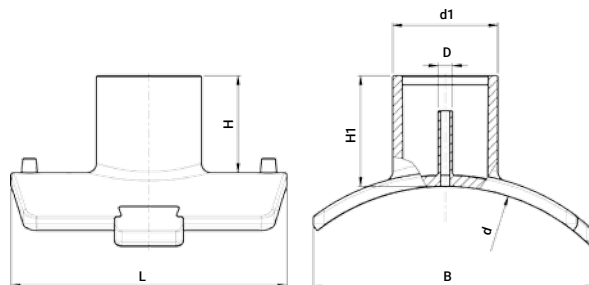

Product Code	Size d x d1	B	H	H1	L	UC	W
495804400090T	250 - 400 x 90	305	102	115	300	7	1510
495804400110T	250 - 400 x 110	305	104	117	300	7	1650
495804400125T	250 - 400 x 125	305	119	110	300	6	1680
495804400160T	280 - 400 x 160	305	119	132	300	6	2167
495804710090T	450 - 800 x 90	315	105	117	300	7	1598
495804710110T	450 - 800 x 110	315	105	117	300	7	1601
495804710125T	450 - 800 x 125	315	109	117	300	7	1739
495804710160T	450 - 800 x 160	315	115	130	300	6	2017

* See dedicated tools on page 175 | * Ver herramientas necesarias en pag. 175

XL&XXL Branch Saddle*

NEW!

495803

XL&XXL Collarín de Derivación

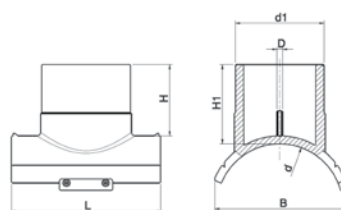

Product Code	d x d1	B	L	H	H1	D	UC	W
495803400250T	400 x 250	390	420	140	200	16	1	7400
495803450250T	450 x 250	386	460	160	198	16	1	7500
495803500315T	500 x 315	480	540	180	227	16	1	13500
495803630250T	500 - 630 x 250	400	420	203	225	16	1	6670
495803560315T	560 x 315	472	540	180	227	16	1	14000
495803560400T	560 x 400	505	620	209	258	16	1	20100
495803630315T	630 x 315	481	540	180	227	16	1	20000
495803630400T	630 x 400	520	620	209	258	16	1	20400
495803900125T	900 x 125*	320	300	110	130	16	1	—
495803900250T	900 x 250*	425	487	160	207	16	1	7000

* Water rating pressure PN10

* See dedicated tools on page 175 | * Ver herramientas necesarias en pag. 175

LightFit Branch Saddle

NEW!

4758W

Collarín de Derivación LightFit

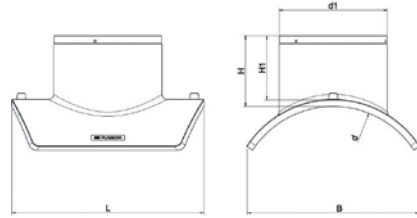

Product Code	d x DN	B	L	H	H1	UC	W
4758W4450225	315 - 450 x 225	359	145	130	400	1	3700
4758W4630225	450 - 630 x 225	389	145	130	400	1	3740
4758W4800225	630 - 800 x 225	407	145	130	400	1	3835

Flange Branch Saddle

495904

Collarín bridado

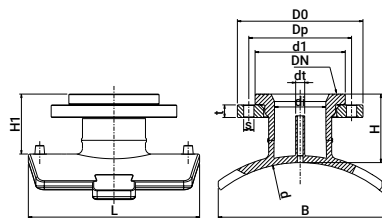

Product Code	d x DN	Flange Type	B	L	H	H1	dt	DO	Dp	di	d1	t	s	No. Holes	UC	W
495904400080T	250 - 400 x 80	ISO/DIN PN 10/16	305	300	115	105	16	200	160	71	138	20	18	8	1	2930
495904710080T	450 - 800 x 80	ISO/DIN PN 10/16	315	300	117	105	16	200	160	71	138	20	18	8	1	2960
495904400100T	250 - 400 x 100	ISO/DIN PN 10/16	305	300	121	110	16	200	180	99	158	22	18	8	1	3390
495904710100T	450 - 800 x 100	ISO/DIN PN 10/16	315	300	123	110	16	200	180	99	158	22	18	8	1	3350
495904400150T	250 - 400 x 150	ISO/DIN PN 10/16	305	300	132	120	16	285	240	127	212	24	18	8	1	6330
495904710150T	450 - 800 x 150	ISO/DIN PN 10/16	315	300	132	120	16	285	240	127	212	24	18	8	1	6300
495903900150T	900 x 150	ISO/DIN PN 10/16	—	—	—	—	16	285	240	127	212	24	18	8	1	—
495903400200T	400 x 200	ISO/DIN PN 16	377	470	210	175	16	344	295	159	268	28	22	12	1	—
495903450200T	450 x 200	ISO/DIN PN 16	387	470	210	175	16	344	295	159	268	28	22	12	1	—
495903500200T	500 x 200	ISO/DIN PN 16	398	470	210	175	16	344	295	159	268	28	22	12	1	—
495903560200T	560 x 200	ISO/DIN PN 16	400	470	210	175	16	344	295	159	268	28	22	12	1	—
495903630200T	630 x 200	ISO/DIN PN 16	405	470	210	175	16	344	295	159	268	28	22	12	1	—
495903710200T	710 x 200	ISO/DIN PN 16	410	470	210	175	16	344	295	159	268	28	22	12	1	—
495903800200T	800 x 200	ISO/DIN PN 16	410	470	210	175	16	344	295	159	268	28	22	12	1	—
495903900200T	900 x 200	ISO/DIN PN 16	415	470	210	175	16	344	295	159	268	28	22	12	1	—
495903400250T	400 x 250	ISO/DIN PN 16	390	420	230	170	16	410	355	199	320	33	26	12	1	16300
495903450250T	450 x 250	ISO/DIN PN 16	386	460	230	190	16	410	355	199	320	33	26	12	1	—
495903630250T	500 - 630 x 250	ISO/DIN PN 16	400	420	255	233	16	410	355	199	320	33	26	12	1	15400
495903710250T	710 x 250	ISO/DIN PN 16	430	470	230	190	16	410	355	199	320	33	26	12	1	—
495903800250T	800 x 250	ISO/DIN PN 16	430	470	230	190	16	410	355	199	320	33	26	12	1	—
495903900250T	900 x 250	ISO/DIN PN 16	440	470	230	190	16	410	355	199	320	33	26	12	1	—
495903450300T	450 x 300	ISO/DIN PN 16	450	530	250	210	16	467	410	251	370	40	26	12	1	—
495903500300T	500 x 300	ISO/DIN PN 16	480	540	260	210	16	467	410	251	370	40	26	12	1	—
495903560300T	560 x 300	ISO/DIN PN 16	472	540	260	210	16	467	410	251	370	40	26	12	1	—
495903630300T	630 x 300	ISO/DIN PN 16	481	540	250	210	16	467	410	251	370	40	26	12	1	—
495903710300T	710 x 300	ISO/DIN PN 16	500	530	250	210	16	467	410	251	370	40	26	12	1	—
495903800300T	800 x 300	ISO/DIN PN 16	510	530	250	210	16	467	410	251	370	40	26	12	1	—
495903900300T	900 x 300	ISO/DIN PN 16	510	530	250	210	16	467	410	251	370	40	26	12	1	—
495903560400T	560 x 400	ISO/DIN PN 16	505	620	290	240	16	595	525	319	482	54	30	16	1	—
495903630400T	630 x 400	ISO/DIN PN 16	520	620	288	239	16	595	525	319	482	54	30	16	1	—
495903710400T	710 x 400	ISO/DIN PN 16	530	610	280	240	16	595	525	319	482	54	30	16	1	—
495903800400T	800 x 400	ISO/DIN PN 16	540	610	280	240	16	595	525	319	482	54	30	16	1	—
495903900400T	900 x 400	ISO/DIN PN 16	550	610	280	240	16	595	525	319	482	54	30	16	1	—

* See dedicated tools on page 175 | * Ver herramientas necesarias en pag. 175

Repair Saddle

495204

Collarín de reparación

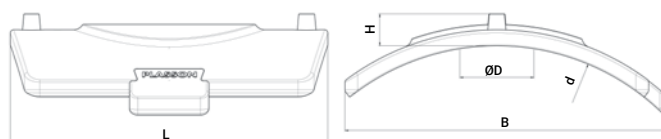

Product Code	Size d	B	H	L	D	UC	W
495204900	R215	305	30	300	70	—	1330

Tapping Saddle

496304

Toma de Servicio



40mm up to 63mm 75mm up to 180mm 200mm up to 250mm

Product Code	Type	Size d x d1	H	B	H1	H2	L	Welding Cup Type	UC	W
496304040020	mb	40 x 20	107	66	7	94	100	Type C	52	290
496304040025	mb	40 x 25	90	65	7	98	100	Type C	40	349
496304040032	mb	40 x 32	121	66	11	94	100	Type C	52	370
496304050020	mb	50 x 20	110	76	7	98	100	Type C	52	390
496304050025	mb	50 x 25	91	76	10	98	100	Type C	52	390
496304050032	mb	50 x 32	122	76	12	98	100	Type C	52	380
496304063020N	mb	63 x 20	90	100	10	90	118	Type C	40	355
496304063025N	mb	63 x 25	93	100	12	36	118	Type C	40	434
496304063032N	mb	63 x 32	99	100	12	90	118	Type C	40	380
496304063040		63 x 40	142	100	64	177	118	Type A	16	1080
496304063050		63 x 50	154	100	64	177	118	Type A	16	1099
496304063063		63 x 63	175	100	64	177	118	Type A	16	1183
496304075020		75 x 20	125	117	50	177	118	Type A	16	1120
496304075032		75 x 32	132	117	56	177	118	Type A	16	1091
496304075040		75 x 40	142	117	60	177	118	Type A	16	1124
496304075050		75 x 50	123	117	64	177	118	Type A	16	1139
496304075063		75 x 63	175	117	64	177	118	Type A	16	1228
496304090020	mb	90 x 20	117	126	16	114	118	Type B	20	900
496304090025	mb	90 x 25	108	126	16	114	118	Type B	20	1120
496304090032	mb	90 x 32	126	126	16	114	118	Type B	20	1120
496304090040	mb	90 x 40	134	126	21	114	118	Type B	20	1130
496304090050		90 x 50	123	126	64	177	118	Type A	14	1220
496304090063		90 x 63	175	126	64	177	118	Type A	14	1300
496304110020	mb	110 x 20	119	148	16	114	118	Type B	20	964
496304110025		110 x 25	118	148	16	114	118	Type B	20	964
496304110032	mb	110 x 32	127	148	16	114	118	Type B	20	970
496304110040	mb	110 x 40	138	148	21	114	118	Type B	20	1000
496304110050		110 x 50	123	148	64	177	118	Type A	12	1300
496304110063		110 x 63	175	148	64	177	118	Type A	12	1383
496304125020	mb	125 x 20	116	162	16	114	118	Type B	15	1220
496304125032	mb	125 x 32	131	162	16	114	118	Type B	15	1230
496304125040	mb	125 x 40	141	162	21	114	118	Type B	15	1280
496304125050		125 x 50	123	162	64	177	118	Type A	12	1345
496304125063		125 x 63	175	162	64	177	118	Type A	12	1420
496304140020		140 x 20	125	180	50	177	118	Type A	12	1340
496304140032		140 x 32	132	180	56	177	118	Type A	12	1330
496304140040		140 x 40	142	180	60	177	118	Type A	12	1360
496304140050		140 x 50	123	180	64	177	118	Type A	12	1382
496304140063		140 x 63	175	180	64	177	118	Type A	12	1468
496304160020	mb	160 x 20	118	199	21	138	118	Type A	10	1360
496304160032	mb	160 x 32	144	199	16	138	118	Type A	10	1320
496304160040	mb	160 x 40	157	199	21	138	118	Type A	10	1439
496304160050	mb	160 x 50	175	199	24	138	118	Type A	10	1375
496304160063	mb	160 x 63	197	199	20	138	118	Type A	10	1390

* Please note: mb = Mono Block | * Nota: mb = monobloque

Tapping Saddle

496304

Toma de Servicio



40mm up to 63mm 75mm up to 180mm 200mm up to 250mm

Product Code	Type	Size d x d1	H	B	H1	H2	L	Welding Cup Type	UC	W
496304180020		180 x 20	125	219	50	177	118	Type A	10	1550
496304180032	mb	180 x 32	144	219	18	138	118	Type A	10	1565
496304180040	mb	180 x 40	155	219	21	138	118	Type A	10	1580
496304180050	mb	180 x 50	174	219	24	138	118	Type A	10	1595
496304180063	mb	180 x 63	197	219	20	138	118	Type A	10	1605
496304200020		200 x 20	125	202	50	177	176	Type A	8	1425
496304200032		200 x 32	132	202	56	177	176	Type A	8	1445
496304200040		200 x 40	142	202	60	177	176	Type A	8	1471
496304200050		200 x 50	123	202	64	177	176	Type A	8	1496
496304200063		200 x 63	175	202	64	177	176	Type A	8	1579
496304225020		225 x 20	125	227	50	177	176	Type A	8	1370
496304225032		225 x 32	132	227	56	177	176	Type A	8	1450
496304225040		225 x 40	142	227	60	177	176	Type A	8	1485
496304225050		225 x 50	123	227	64	177	176	Type A	8	1506
496304225063		225 x 63	175	227	64	177	176	Type A	8	1589
496304250020		250 x 20	125	252	50	177	176	Type A	8	1380
496304250032		250 x 32	132	252	56	177	176	Type A	8	1464
496304250040		250 x 40	142	252	60	177	176	Type A	8	1582
496304250050		250 x 50	123	252	64	177	176	Type A	8	1589
496304250063		250 x 50	175	252	64	177	176	Type A	8	1595

* Please note: mb = Mono Block | * Nota: mb = monobloque

Tapping Saddle Parallel Outlet

4963P4

Toma de Servicio salida Parallel Outlet

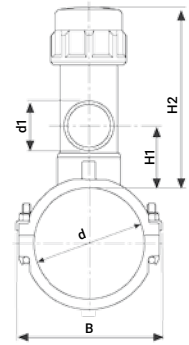
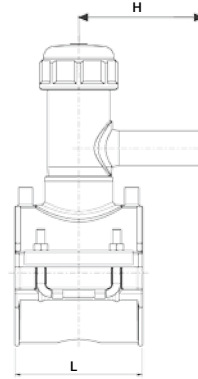

Product Code	Size d x d1	H	B	H1	H2	L	Welding Cup Type	UC	W
4963P4063020	63 x 20	125	100	50	177	118	Type A	16	1035
4963P4063032	63 x 32	132	100	56	177	118	Type A	16	1042
4963P4063040	63 x 40	142	100	60	177	118	Type A	16	1070
4963P4063050	63 x 50	123	100	64	177	118	Type A	16	906
4963P4063063	63 x 63	175	100	64	177	118	Type A	16	1180
4963P4075020	75 x 20	125	117	50	177	118	Type A	16	1120
4963P4075032	75 x 32	132	117	56	177	118	Type A	16	1130
4963P4075040	75 x 40	142	117	60	177	118	Type A	16	1119
4963P4075050	75 x 50	123	117	64	177	118	Type A	16	1140
4963P4075063	75 x 63	175	117	64	177	118	Type A	16	1226
4963P4090020	90 x 20	125	126	50	177	118	Type A	14	1170
4963P4090032	90 x 32	132	126	56	177	118	Type A	14	1120
4963P4090040	90 x 40	142	126	60	177	118	Type A	14	1130
4963P4090050	90 x 50	123	126	64	177	118	Type A	14	1235
4963P4090063	90 x 63	175	126	64	177	118	Type A	14	1270
4963P4110020	110 x 20	125	148	50	177	118	Type A	12	1240
4963P4110032	110 x 32	132	148	56	177	118	Type A	12	1175
4963P4110040	110 x 40	142	148	60	177	118	Type A	12	1179
4963P4110050	110 x 50	123	148	64	177	118	Type A	12	1293
4963P4110063	110 x 63	175	148	64	177	118	Type A	12	1380
4963P4125020	125 x 20	125	162	50	177	118	Type A	10	1275
4963P4125032	125 x 32	132	162	56	177	118	Type A	10	1298
4963P4125040	125 x 40	142	162	60	177	118	Type A	10	1320
4963P4125050	125 x 50	123	162	64	177	118	Type A	10	1335
4963P4125063	125 x 63	175	162	64	177	118	Type A	10	1426
4963P4140020	140 x 20	125	180	50	177	118	Type A	10	1340
4963P4140032	140 x 32	132	180	56	177	118	Type A	10	1330
4963P4140040	140 x 40	142	180	60	177	118	Type A	10	1360
4963P4140050	140 x 50	123	180	64	177	118	Type A	10	1370
4963P4140063	140 x 63	175	180	64	177	118	Type A	10	1468
4963P4160020	160 x 20	125	199	50	177	118	Type A	10	1390
4963P4160032	160 x 32	132	199	56	177	118	Type A	10	1304
4963P4160040	160 x 40	142	199	60	177	118	Type A	10	1327
4963P4160050	160 x 50	123	199	64	177	118	Type A	10	1348
4963P4160063	160 x 63	175	199	64	177	118	Type A	10	1399
4963P4180020	180 x 20	125	219	50	177	118	Type A	8	1550
4963P4180032	180 x 32	132	219	56	177	118	Type A	8	1304
4963P4180040	180 x 40	142	219	60	177	118	Type A	8	1490
4963P4180050	180 x 50	123	219	64	177	118	Type A	8	1515
4963P4180063	180 x 63	175	219	64	177	118	Type A	8	1304
4963P4200020	200 x 20	125	202	50	177	176	Type A	8	1360
4963P4200032	200 x 32	132	202	56	177	176	Type A	8	1451
4963P4200040	200 x 40	142	202	60	177	176	Type A	8	1405
4963P4200050	200 x 50	123	202	64	177	176	Type A	8	1425
4963P4200063	200 x 63	175	202	64	177	176	Type A	8	1510
4963P4225020	225 x 20	125	227	50	177	176	Type A	8	1370
4963P4225032	225 x 32	132	227	56	177	176	Type A	8	1450
4963P4225040	225 x 40	142	227	60	177	176	Type A	8	1485
4963P4225050	225 x 50	123	227	64	177	176	Type A	8	1506
4963P4225063	225 x 63	175	227	64	177	176	Type A	8	1586
4963P4250020	250 x 20	125	252	50	177	176	Type A	8	1380
4963P4250032	250 x 32	132	252	56	177	176	Type A	8	1569
4963P4250040	250 x 40	142	252	60	177	176	Type A	8	1582
4963P4250050	250 x 50	123	252	64	177	176	Type A	8	1589
4963P4250063	250 x 63	175	252	64	177	176	Type A	8	1595

Welding Cap for Tapping Saddle

498304

Tapón Soldable para toma de servicio

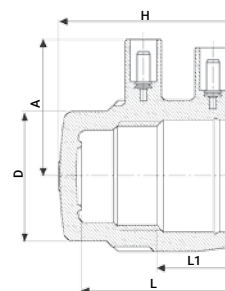

Product Code	Type	Size	D	A	H	L	L1	UC	W
498304057	Type A	57	74	59	74	63	36	128	157
498304050	Type B	50	62	54	73	66	30	192	111
498304040	Type C	40	51	49	63	55	26	256	73

* Please use Welding Cap Type as specified on page 175 | * Utilizar el tipo de tapón soldable como se indica en la página 175

PE Ball Valve

436207

Válvula de Bola PE

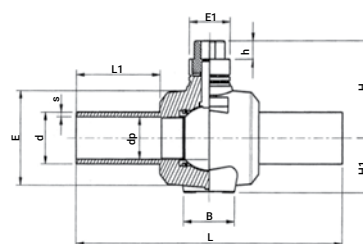

Product Code	Size d	dp	s	L	L1	B	E	E1	H	H1	h	UC	W
436207025	25*	19	3	300	103	65	80	70	94	50	40	12	705
436207032	32*	24	3	300	103	65	80	70	94	50	40	12	705
436207040	40	24	4	300	103	65	80	70	94	50	40	12	758
436207050	50*	39	6	414	130	87	120	85	160	80	40	4	2091
436207063	63*	48	6	414	130	87	120	85	160	80	40	4	2061
436207075	75	48	8	414	130	87	120	85	160	80	40	4	2293
436207090	90*	70	8	550	176	93	200	85	200	110	40	2	5865
436207110	110*	86	10	550	178	93	200	85	200	110	40	2	5761
436207125	125	86	12	550	182	93	200	85	200	110	40	2	6300
436207160	160	86	16	550	182	93	200	85	200	110	40	2	7100

* Full Bore Dimensions | * Dimensiones de cavidad única

Tapping Valve

495404

Toma de Servicio con Válvula

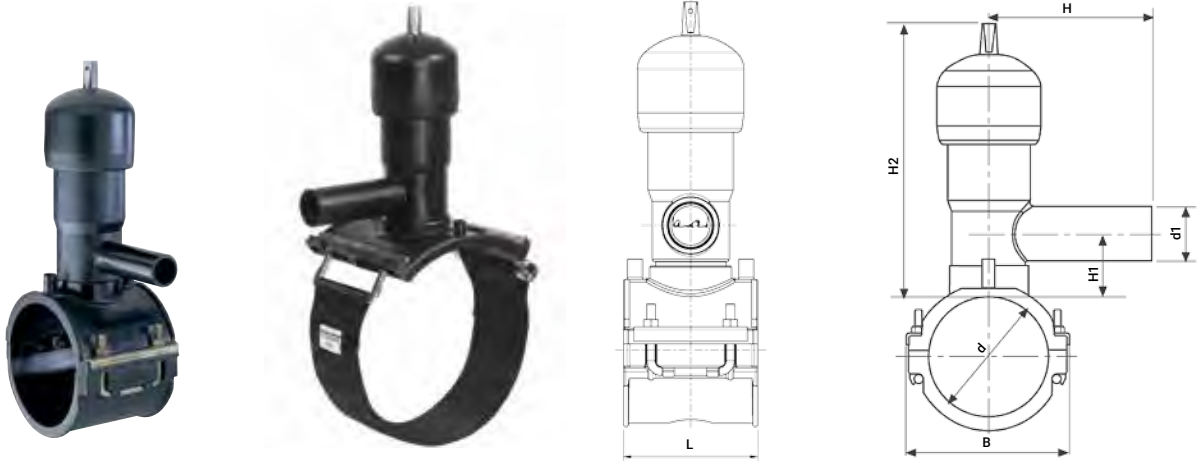

63mm up to 180mm

200mm up to 250mm

Product Code	Size d x d1	B	H	H1	H2	L	UC	W
495404063032	63 x 32	99	126	46	244	118	8	2090
495404063040	63 x 40	99	137	46	244	118	8	2103
495404063050	63 x 50	99	152	51	244	118	8	2140
495404063063	63 x 63	99	186	51	244	118	8	2205
495404075032	75 x 32	117	126	46	244	118	8	2100
495404075040	75 x 40	117	137	46	244	118	8	2113
495404075050	75 x 50	117	152	51	244	118	8	2150
495404075063	75 x 63	117	186	51	244	118	8	2215
495404090032	90 x 32	126	126	46	244	118	8	2150
495404090040	90 x 40	126	137	46	244	118	8	2163
495404090050	90 x 50	126	152	51	244	118	8	2200
495404090063	90 x 63	126	186	51	244	118	8	2265
495404110032	110 x 32	148	126	46	244	118	8	2266
495404110040	110 x 40	148	137	46	244	118	8	2250
495404110050	110 x 50	148	152	51	244	118	8	2279
495404110063	110 x 63	148	186	51	244	118	8	2345
495404125032	125 x 32	162	126	46	244	118	8	2276
495404125040	125 x 40	162	137	46	244	118	8	2289
495404125050	125 x 50	162	152	51	244	118	8	2326
495404125063	125 x 63	162	186	51	244	118	8	2391
495404140032	140 x 32	180	126	46	244	118	8	2285
495404140040	140 x 40	180	137	46	244	118	8	2298
495404140050	140 x 50	180	152	51	244	118	8	2335
495404140063	140 x 63	180	186	51	244	118	8	2441
495404160032	160 x 32	202	126	46	244	118	8	2377
495404160040	160 x 40	202	137	46	244	118	8	2390
495404160050	160 x 50	202	152	51	244	118	8	2427
495404160063	160 x 63	202	186	51	244	118	8	2492
495404180032	180 x 32	220	126	46	244	118	8	2440
495404180040	180 x 40	220	137	46	244	118	8	2453
495404180050	180 x 50	220	152	51	244	118	8	2490
495404180063	180 x 63	220	186	51	244	118	8	2550
495404200032	200 x 32	202	126	46	244	176	5	2431
495404200040	200 x 40	202	137	46	244	176	5	2444
495404200050	200 x 50	202	152	51	244	176	5	2481
495404200063	200 x 63	202	186	51	244	176	5	2546
495404225032	225 x 32	227	126	46	244	176	5	2448
495404225040	225 x 40	227	137	46	244	176	5	2501
495404225050	225 x 50	227	152	51	244	176	5	2538
495404225063	225 x 63	227	186	51	244	176	5	2603
495404250032	250 x 32	252	126	46	244	176	5	2504
495404250040	250 x 40	252	137	46	244	176	5	2517
495404250050	250 x 50	252	152	51	244	176	5	2554
495404250063	250 x 63	252	186	51	244	176	5	2619

Tapping Valve

4954S4*

Toma de Servicio con Válvula

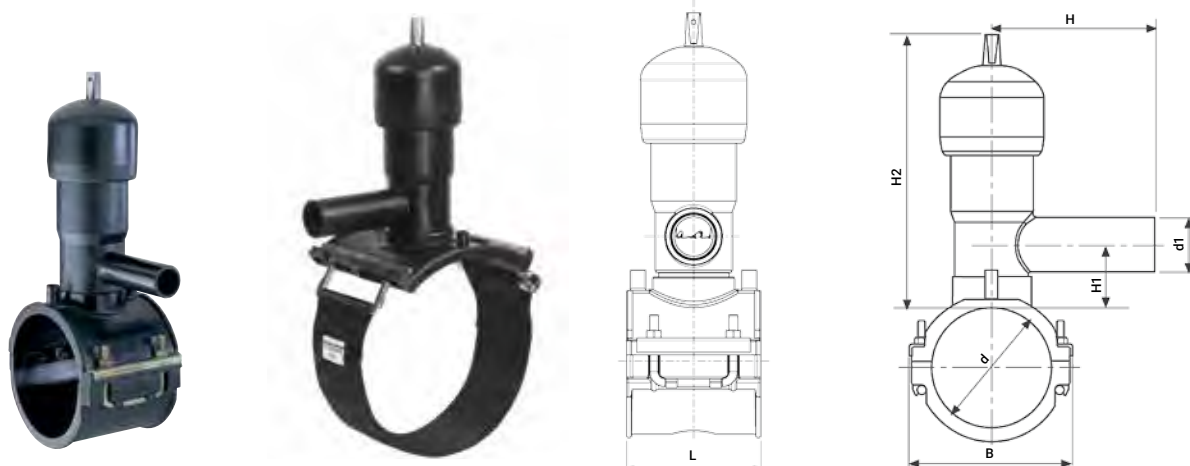

63mm up to 180mm

200mm up to 250mm

Product Code	Size d x d1	B	H	H1	H2	L	UC	W
4954S4063032	63 x 32	103	126	46	244	118	8	2100
4954S4063040	63 x 40	103	137	46	244	118	8	2113
4954S4063050	63 x 50	103	152	51	244	118	8	2150
4954S4063063	63 x 63	103	186	51	244	118	8	2215
4954S4075032	75 x 32	117	126	46	244	118	8	2110
4954S4075040	75 x 40	117	137	46	244	118	8	2123
4954S4075050	75 x 50	117	152	51	244	118	8	2160
4954S4075063	75 x 63	117	186	51	244	118	8	2225
4954S4090032	90 x 32	124	126	46	244	118	8	2160
4954S4090040	90 x 40	124	137	46	244	118	8	2173
4954S4090050	90 x 50	124	152	51	244	118	8	2210
4954S4090063	90 x 63	124	186	51	244	118	8	2275
4954S4110032	110 x 32	145	126	46	244	118	8	2277
4954S4110040	110 x 40	145	137	46	244	118	8	2260
4954S4110050	110 x 50	145	152	51	244	118	8	2290
4954S4110063	110 x 63	145	186	51	244	118	8	2355
4954S4125032	125 x 32	162	126	46	244	118	8	2287
4954S4125040	125 x 40	162	137	46	244	118	8	2300
4954S4125050	125 x 50	162	152	51	244	118	8	2337
4954S4125063	125 x 63	162	186	51	244	118	8	2402
4954S4140032	140 x 32	178	126	46	244	118	8	2295
4954S4140040	140 x 40	178	137	46	244	118	8	2308
4954S4140050	140 x 50	178	152	51	244	118	8	2345
4954S4140063	140 x 63	178	186	51	244	118	8	2410
4954S4160032	160 x 32	199	126	46	244	118	8	2387
4954S4160040	160 x 40	199	137	46	244	118	8	2400
4954S4160050	160 x 50	199	152	51	244	118	8	2437
4954S4160063	160 x 63	199	186	51	244	118	8	2502
4954S4180032	180 x 32	219	126	46	244	118	8	2450
4954S4180040	180 x 40	219	137	46	244	118	8	2463
4954S4180050	180 x 50	219	152	51	244	118	8	2500
4954S4180063	180 x 63	219	186	51	244	118	8	2565
4954S4200032	200 x 32	202	126	46	244	176	5	2441
4954S4200040	200 x 40	202	137	46	244	176	5	2454
4954S4200050	200 x 50	202	152	51	244	176	5	2491
4954S4200063	200 x 63	202	186	51	244	176	5	2556
4954S4225032	225 x 32	227	126	46	244	176	5	2498
4954S4225040	225 x 40	227	137	46	244	176	5	2511
4954S4225050	225 x 50	227	152	51	244	176	5	2548
4954S4225063	225 x 63	227	186	51	244	176	5	2613
4954S4250032	250 x 32	252	126	46	244	176	5	2514
4954S4250040	250 x 40	252	137	46	244	176	5	2527
4954S4250050	250 x 50	252	152	51	244	176	5	2564
4954S4250063	250 x 63	252	186	51	244	176	5	2629

* Tapping Valve with serrated edge knife. Available in all sizes.

* Toma de servicio con bordes "dientes de sierra". Todos los tamaños.

Male Transition Coupler

492104

Enlace de Transición Macho

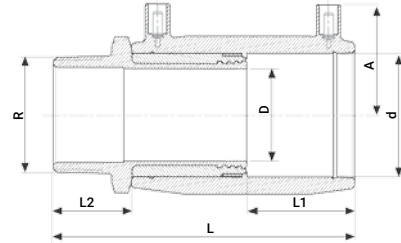

Product Code	Size d x R	L	L1	L2	D	A	UC	W
492104020005	20 x 1/2"	105	37	29	14	34	200	129
492104025007	25 x 3/4"	111	40	29	19	37	150	150
492104032005	32 x 1/2"	110	39	29	23	42	100	142
492104032007	32 x 3/4"	110	39	29	23	42	100	263
492104032010	32 x 1"	122	42	34	23	42	100	285
492104032013	32 x 1 1/4"	124	42	36	23	42	60	393
492104032015	32 x 1 1/2"	124	42	36	23	42	60	404
492104040010	40 x 1"	131	47	34	29	46	72	409
492104040013	40 x 1 1/4"	133	47	36	29	46	54	470
492104040015	40 x 1 1/2"	133	47	36	29	46	54	483
492104040020	40 x 2"	160	44	41	48	59	36	500
492104050010	50 x 1"	135	49	34	38	51	48	513
492104050013	50 x 1 1/4"	137	49	36	38	51	48	569
492104050015	50 x 1 1/2"	137	49	36	38	51	48	547
492104050020	50 x 2"	160	49	41	48	59	30	752
492104063013	63 x 1 1/4"	153	57	36	48	57	30	884
492104063015	63 x 1 1/2"	153	57	36	48	57	30	845
492104063020	63 x 2"	158	57	41	48	57	30	921
492104075020	75 x 2"	167	61	41	59	64	16	1305
492104075025	75 x 2 1/2"	172	61	46	59	64	16	1512

Female Transition Coupler

493104

Enlace de Transición Hembra

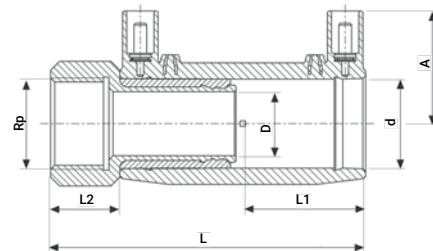

Product Code	Size d x Rp	L	L1	L2	D	A	UC	W
493104020005	20 x 1/2"	96	37	20	14	35	200	130
493104025007	25 x 3/4"	105	40	23	19	38	150	145
493104025010	25 x 1"	108	34	28	23	42	80	252
493104032007	32 x 3/4"	124	39	23	19	42	100	147
493104032010	32 x 1"	113	42	25	23	42	100	265
493104032013	32 x 1 1/4"	118	39	28	29	47	54	507
493104032015	32 x 1 1/2"	124	39	25	38	47	50	455
493104040010	40 x 1"	122	47	25	29	46	54	507
493104040013	40 x 1 1/4"	122	47	25	29	46	54	407
493104040015	40 x 1 1/2"	122	47	25	29	46	48	419
493104040020	40 x 2"	150	44	32	38	59	32	821
493104050015	50 x 1 1/2"	126	49	25	38	51	48	491
493104050020	50 x 2"	131	49	30	38	51	40	685
493104063015	63 x 1 1/2"	145	59	26	38	59	24	558
493104063020	63 x 2"	147	57	30	48	57	30	840

Male Transition Elbow 90°

492504

Codo de Transición de 90° Macho

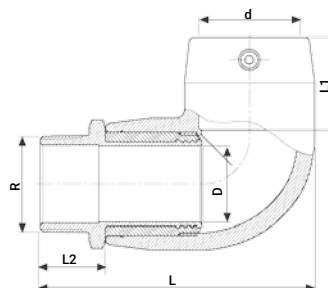

Product Code	Size d x R	L	L1	L2	D	A	UC	W
492504020005	20 x 1/2"	95	35	29	14	38	150	153
492504025007	25 x 3/4"	95	37	29	19	38	120	168
492504032005	32 x 1/2"	112	40	29	23	43	84	259
492504032007	32 x 3/4"	112	40	29	23	43	84	262
492504032010	32 x 1"	117	40	34	23	43	84	300
492504032013	32 x 1.1/4"	119	40	36	23	43	60	419
492504032015	32 x 1.1/2"	119	40	36	23	43	60	436
492504040010	40 x 1"	126	44	34	29	47	48	458
492504040013	40 x 1.1/4"	128	44	36	29	47	48	500
492504040015	40 x 1.1/2"	128	44	36	29	47	48	510
492504040020	40 x 2"	133	44	41	29	47	48	725
492504050010	50 x 1"	142	48	34	38	52	42	624
492504050013	50 x 1.1/4"	144	48	36	38	52	36	679
492504050015	50 x 1.1/2"	144	48	36	38	52	36	655
492504050020	50 x 2"	149	48	41	38	52	30	806
492504063013	63 x 1.1/4"	167	57	36	48	59	24	985
492504063015	63 x 1.1/2"	167	57	36	48	59	24	1040
492504063020	63 x 2"	172	57	41	48	59	24	1125
492504075020	75 x 2"	199	69	41	59	62	16	1450
492504075025	75 x 2.1/2"	204	69	46	59	62	16	1649

Female Transition Elbow 90°

493504

Codo de Transición de 90° Hembra

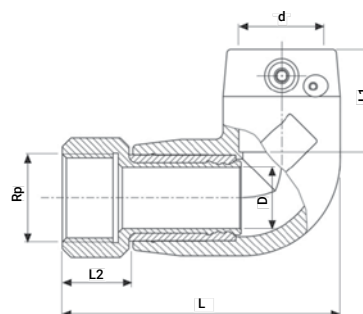

Product Code	Size d x Rp	L	L1	L2	D	A	UC	W
493504020005	20 x 1/2"	86	35	20	14	38	160	142
493504025007	25 x 3/4"	89	37	23	19	38	120	160
493504032007	32 x 3/4"	108	40	25	23	43	96	280
493504032010	32 x 1"	108	40	25	23	43	96	280
493504032015	32 x 1.1/2"	108	40	25	23	43	96	360
493504040010	40 x 1"	117	44	25	29	47	48	535
493504040013	40 x 1.1/4"	117	44	25	29	47	48	432
493504040015	40 x 1.1/2"	117	44	25	29	47	48	453
493504050015	50 x 1.1/2"	133	48	25	38	52	48	560
493504050020	50 x 2"	138	48	30	38	52	40	744
493504063015	63 x 1.1/2"	161	57	30	48	59	24	1072
493504063020	63 x 2"	161	57	30	48	59	24	959

Male Transition Elbow 45°

492604

Codo de Transición de 45° Macho

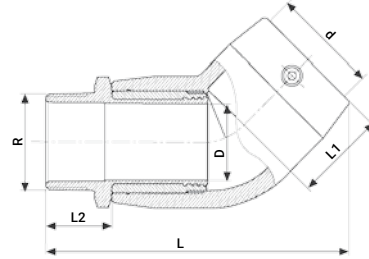

Product Code	Size d x R	L	L1	L2	D	A	UC	W
492604032005	32 x 1/2	124	39	29	23	43	84	249
492604032007	32 x 3/4	123	39	29	23	43	84	250
492604032010	32 x 1"	129	39	34	23	43	72	375
492604032013	32 x 1 1/4"	130	39	36	23	43	48	479
492604032015	32 x 1 1/2"	130	39	36	23	43	48	488
492604040010	40 x 1"	142	44	34	29	47	60	433
492604040013	40 x 1 1/4"	144	44	36	29	47	60	485
492604040015	40 x 1 1/2"	144	44	36	29	47	48	510
492604040020	40 x 2"	149	44	41	29	47	40	685
492604050010	50 x 1"	161	49	34	38	51	48	564
492604050013	50 x 1 1/4"	161	49	36	38	51	48	610
492604050015	50 x 1 1/2"	166	49	36	38	51	48	600
492604050020	50 x 2"	165	49	41	38	51	30	778
492604063013	63 x 1 1/4"	184	57	36	48	59	24	927
492604063015	63 x 1 1/2"	184	57	36	48	59	24	893
492604063020	63 x 2"	189	57	41	48	59	24	953
492604075020	75 x 2"	221	71	41	59	62	16	1399
492604075025	75 x 2 1/2"	226	71	46	59	62	16	1600

Female Transition Elbow 45°

493604

Codo de Transición de 45° Hembra

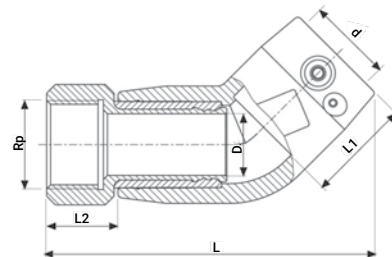

Product Code	Size d x Rp	L	L1	L2	D	A	UC	W
493604032007	32 x 3/4"	120	39	25	23	43	96	320
493604032010	32 x 1"	120	39	25	23	43	72	342
493604032015	32 x 1.1/2"	120	39	25	23	43	72	488
493604040010	40 x 1"	133	44	25	29	47	48	510
493604040013	40 x 1.1/4"	133	44	25	29	47	48	419
493604040015	40 x 1.1/2"	133	44	25	29	47	48	479
493604050015	50 x 1.1/2"	150	49	25	38	51	48	532
493604050020	50 x 2"	155	49	30	38	51	36	714
493604063015	63 x 1.1/2"	178	57	30	48	59	24	1019
493604063020	63 x 2"	178	57	30	48	59	24	912

Female Free Nut Transition Coupler*

494104

Enlace de Transición, Tuerca Libre, Hembra

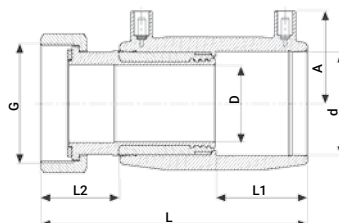

Product Code	Size d x G	L	L1	L2	D	A	UC	W
494104020007	20 x 3/4"	106	37	30	14	34	200	150
494104025007	25 x 3/4"	112	40	30	14	37	140	150
494104025010	25 x 1"	115	40	33	19	37	140	200
494104032007	32 x 3/4"	100	39	20	14	42	100	164
494104032010	32 x 1"	124	42	36	19	42	100	260
494104032013	32 x 1 1/4"	124	42	36	23	42	78	310
494104040010	40 x 1"	115	44	25	19	47	52	278
494104040013	40 x 1 1/4"	113	44	23	23	47	52	320
494104040015	40 x 1 1/2"	135	47	38	29	45	52	444
494104050010	50 x 1"	136	49	36	19	52	32	700
494104050013	50 x 1"	120	49	23	23	52	32	371
494104050015	50 x 1"	123	49	25	29	52	32	484
494104050020	50 x 2"	141	49	41	38	52	32	709
494104063020	63 x 2"	161	57	44	38	57	28	770
494104063025	63 x 2 1/2"	166	57	49	48	57	20	1154

* May be converted into male free nut by addition of a threaded nipple.

* Se puede convertir en la tuerca loca macho mediante la adición de un niple roscado.

Female Free Nut Transition Elbow 90°*

494504

Codo de Transición de 90° Tuerca Libre, Hembra

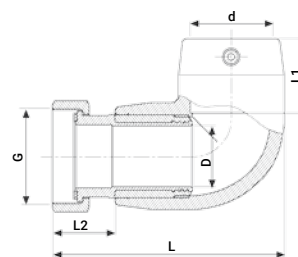

Product Code	Size d x G	L	L1	L2	D	A	UC	W
494504020007	20 x 3/4"	96	35	30	14	38	140	164
494504025007	25 x 3/4"	96	37	30	14	38	140	164
494504025010	25 x 1"	99	37	33	19	38	105	164
494504032010	32 x 1"	119	40	36	19	43	70	164
494504032013	32 x 1.1/4"	119	40	36	23	43	70	324
494504040015	40 x 1.1/2"	132	44	40	29	47	48	490
494504050020	50 x 2"	149	48	41	38	52	30	779
494504063020	63 x 2"	175	57	44	41	59	16	1024
494504063025	63 x 2.1/2"	180	57	49	48	59	16	1245

* May be converted into male free nut by addition of a threaded nipple.

* Se puede convertir en la tuerca loca macho mediante la adición de un niple roscado.

Female Free Nut Transition Elbow 45°*

494604

Codo de Transición de 45° Tuerca Libre, Hembra

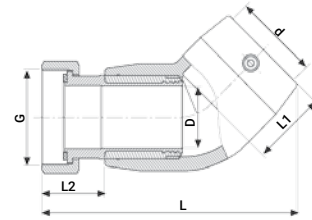

Product Code	Size d x G	L	L1	L2	D	A	UC	W
494604032010	32 x 1"	131	39	36	19	43	70	164
494604032013	32 x 1.1/4"	129	39	34	23	47	56	400
494604040015	40 x 1.1/2"	146	44	38	29	47	48	469
494604050020	50 x 2"	166	49	41	38	51	30	740
494604063020	63 x 2"	189	57	41	38	59	24	950
494604063025	63 x 2.1/2"	197	57	44	48	59	16	1184

* May be converted into male free nut by addition of a threaded nipple.

* Se puede convertir en la tuerca loca macho mediante la adición de un niple roscado.

Female Union Free Nut Transition Tee

494404

Enlace T, PE/Latón, Tuerca Libre, Hembra

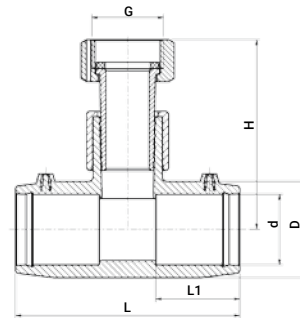

Product Code	Size d x G	L	L1	D	H	A	UC	W
494404032010	32 x 1"	104	39	44	88	43	50	320

PE Male Transition Coupler

497104

Enlace de Transición PE Macho

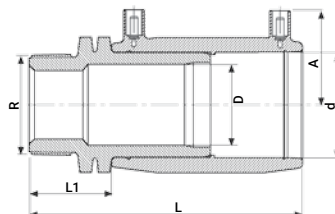

Product Code	Size d x R	D	L	L1	UC	W
497104020005	20 x 1/2"	14	97	21	200	129
497104025007	25 x 3/4"	18	113	31	200	61
497104032010	32 x 1"	24	123	35	200	92
497104040010	40 x 1"	30	134	37	128	146
497104040013	40 x 1.1/4"	30	137	40	144	152
497104040015	40 x 1.1/2"	30	137	40	128	159
497104050015	50 x 1.1/2"	38	141	40	96	238
497104063015	63 x 1.1/2"	48	161	44	40	371
497104063020	63 x 2"	48	165	48	40	450

PE Male Transition Elbow 90°

497504

Codo de Transición PE de 90° Macho

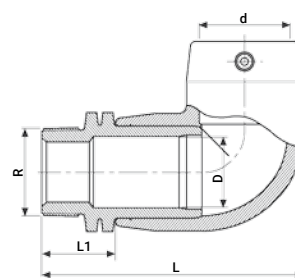

Product Code	Size d x R	A	D	L	L1	UC	W
497504020005	20 x 1/2"	38	14	87	35	200	458
497504025007	25 x 3/4"	38	18	97	37	200	77
497504032010	32 x 1"	43	24	118	40	96	120
497504040010	40 x 1"	47	30	129	44	48	187
497504040013	40 x 1.1/4"	47	30	132	44	48	202
497504040015	40 x 1.1/2"	47	30	132	44	48	250
497504050015	50 x 1.1/2"	52	38	148	48	48	296
497504063015	63 x 1.1/2"	59	48	175	57	24	458
497504063020	63 x 2"	59	48	179	57	24	471

PE Male Transition Elbow 45°

497604

Codo de Transición PE de 45° Macho

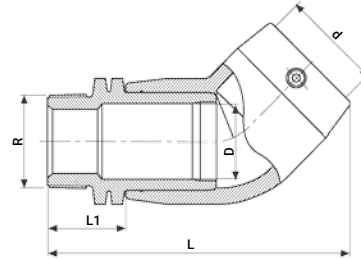

Product Code	Size d x R	D	L	L1	UC	W
497604032010	32 x 1"	24	141	39	96	150
497604040010	40 x 1"	30	145	42	96	175
497604040013	40 x 1.1/4"	30	148	42	96	185
497604040015	40 x 1.1/2"	30	148	42	96	185
497604050015	50 x 1.1/2"	38	165	49	48	271
497604063015	63 x 1.1/2"	48	192	57	24	465
497604063020	63 x 2"	48	196	57	24	470

PE Cast Iron Flange Transition Coupler

497704

Enlace de Transición Bridado - PE Hierro Fundido

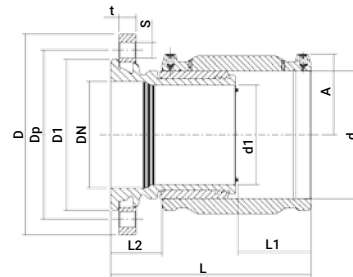

Product Code	Size d x DN	A	L	L1	L2	D1	d1	D	Dp	s	t	No. of holes	UC	W
497704063	63 x 50	57	217	57	100	104	43	165	125	18	20	4	4	4200
497704090	90 x 80	70	216	73	68	139	67	200	160	18	20	8	4	5940
497704110	110 x 100	79	223	80	61	159	84	220	180	18	22	8	4	7280
497704125	125 x 100	87	235	85	62	159	98	220	180	18	22	8	4	7759
497704160	160 x 150	105	268	93	73	215	125	285	240	22	24	8	1	13400
497704180	180 x 150	116	284	105	72	215	140	285	240	22	24	8	1	15246
497704225	225 x 200	138	314	119	74	270	176	340	295	22	26	8	1	23919

PE Cast Iron Spigot Transition Coupler

495704

Enlace de Transición Espiga - PE Hierro Fundido

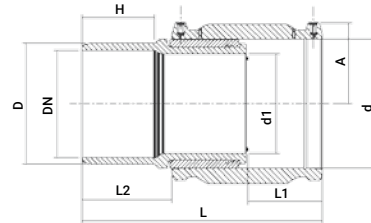

Product Code	Size d x DN	A	L	L1	L2	D	d1	H	UC	W
495704090080	90 x 80	69	254	73	106	98	67	94	8	2874
495704110100	110 x 100	79	275	80	112	118	84	96	8	4170
495704125100	125 x 100	87	280	85	107	118	98	91	8	4569
495704160150	160 x 150	104	322	97	124	170	125	102	8	8105
495704180150	180 x 150	114	339	104	127	170	140	103	8	10121
495704225200	225 x 200	140	372	118	132	222	176	109	8	12284

Full Face Flange

490209

Brida de Cara Plana

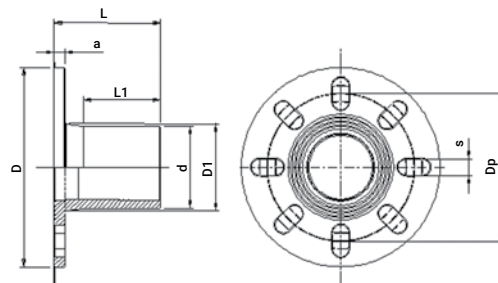

Product Code	Size d	L	L1	D	D1	a	Dp	s	UC	W
490209090	90	118	86	220	98	12	163	20	18	995
490209110	110	—	—	—	—	—	—	—	—	—
490209125	125	—	—	—	—	—	—	—	3	600
490209160	160	—	—	—	—	—	—	—	2	1750
490209180	180	—	—	—	—	—	—	—	2	1610
490209225	225	—	—	—	—	—	—	—	—	—

Stub Flange

490207

Adaptador de Brida

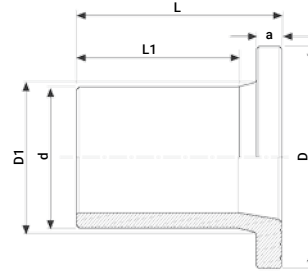

Product Code	Size d	L	L1	a	D	D1	UC	W
490207020	20	85	45	7	45	26	160	26
490207025	25	85	40	9	58	32	160	42
490207032	32	85	60	10	68	40	160	57
490207040	40	85	60	11	78	50	160	84
490207050	50	104	75	12	88	61	144	132
490207063	63	120	87	14	102	75	60	220
490207075	75	130	92	16	122	89	48	322
490207090	90	140	96	17	138	105	32	475
490207110	110	160	110	18	158	125	20	747
490207125	125	182	132	25	158	132	16	945
490207140	140	180	130	25	188	155	12	1245
490207160	160	180	130	25	212	175	8	1600
490207180	180	198	140	30	212	187	8	1990
490207200	200	200	135	32	268	232	4	3100
490207225	225	200	135	32	268	235	4	3360
490207250	250	215	145	35	320	285	3	5080
490207280	280	228	160	35	320	291	2	5605
490207315	315	238	160	35	370	335	2	7470
490207355	355	255	175	40	430	373	1	10475
490207400	400	286	195	45	482	427	1	14970

Flange Backing Ring

09903

Brida Revestida

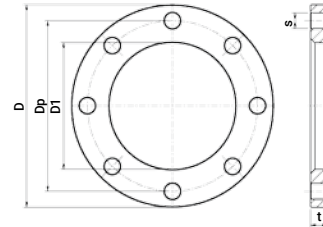

Product Code	Flange Type	Flange	D	Dp	D1	s	t	No. of Holes	UC	W
09903020	ISO/DIN PN 10/16	20 x 1/2"	95	65	28	14	12	4	200	240
09903025	ISO/DIN PN 10/16	25 x 3/4"	105	75	34	14	14	4	180	300
09903032	ISO/DIN PN 10/16	32 x 1"	115	85	42	14	16	4	150	490
09903040	ISO/DIN PN 10/16	40 x 1.1/4"	140	100	51	18	18	4	120	685
09903050	ISO/DIN PN 10/16	50 x 1.1/2"	150	110	62	18	18	4	100	812
09903063	ISO/DIN PN 10/16	63 x 2"	165	125	78	18	18	4	20	1110
09903075	ISO/DIN PN 10/16	75 x 2.1/2"	185	145	92	18	20	4	—	1160
09902095	ISO/DIN PN 10/16	90 x 2.1/2"	185	145	102	18	20	8	—	—
09903090	ISO/DIN PN 10/16	90 x 3"	200	160	108	18	20	8	100	1400
09903110	ISO/DIN PN 10/16	110 x 4"	220	180	128	18	22	8	100	1570
09903125	ISO/DIN PN 10/16	125 x 4"	220	180	135	18	22	8	—	1470
09903140	ISO/DIN PN 10/16	140 x 5"	250	210	158	18	22	8	30	1930
09903160	ISO/DIN PN 10/16	160 x 6"	285	240	178	22	24	8	12	2700
09903180	ISO/DIN PN 10/16	180 x 6"	285	240	188	22	24	8	10	2150
09903200	ISO/DIN PN 10	200 x 8"	340	295	235	22	24	8	4	3600
09903225	ISO/DIN PN 10	225 x 8"	340	295	238	22	24	8	8	3510
09903250	ISO/DIN PN 10	250 x 10"	395	350	288	22	26	12	8	5200
09901250	BS 10 Table D	250 x 10" BS	395	355	288	22	26	8	—	—
09903280	ISO/DIN PN 10	280 x 10"	395	350	294	22	26	12	4	5500
09901280	BS 10 Table D	280 x 10" BS	395	355	294	22	26	8	—	—
09903315	ISO/DIN PN 10	315 x 12"	445	400	338	22	26	12	3	8350
09901315	BS 10 Table D	315 x 12" BS	445	406	338	22	26	12	—	—
09901355	BS 10 Table D	355 x 14" BS	520	470	376	26	12	16	—	—

Wastewater System, We Make the Connection

Polyethylene offers the ideal cost-effective and technically superior alternative to other materials, requiring minimal effort to install, reducing the number of connections required and increasing the system lifespan.

The Plasson System constitutes an excellent investment for both public wastewater infrastructures and private wastewater systems

The Plasson wastewater system offers a strong, long-life and is resistant to axial loads through its special versatile products that can be completely fused after being laid.



Systemas de Aguas Residuales, Hacemos la Conexión

En comparación con otros materiales, el polietileno constituye la alternativa ideal en términos de costo-beneficio y superioridad técnica, ya que requiere un mínimo esfuerzo de instalación, con menos conexiones, y asegura una larga vida útil. El sistema de Plasson es una inversión excelente, tanto para las infraestructuras públicas de aguas residuales como para los sistemas privados.

Los sistemas de Plasson para aguas residuales son muy duraderos y resistentes a las cargas axiales, gracias a la versatilidad de sus productos que pueden fusionarse completamente después de la instalación.

Wastewater Adjustable Saddle

475804

Ramal Para Aguas Residuales

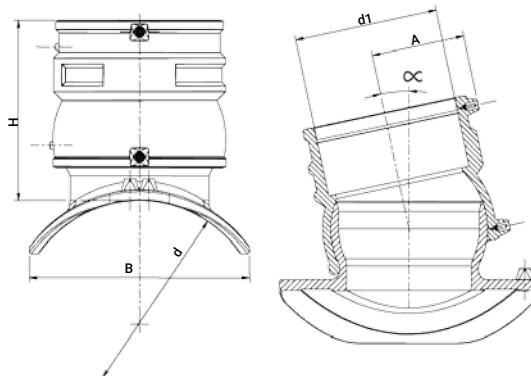

Product Code	Size d x d1	B	H	A	L	UC	W
475804200160	200 x 160	208	202	105	290	4	2050
475804250160	225-250 x 160	225	202	105	290	4	2060
475804315160	280-315 x 160	247	202	105	290	4	2070
475804560160	355-560 x 160	263	202	105	290	4	2080
475804710160	560-710 x 160	277	202	105	290	4	2080

* See dedicated tools on page 172 | * Ver herramientas necesarias en pag. 172

Wastewater Saddle 45° - Inlet 110

4758A4

Ramal 45° de Salida Para Aguas Residuales

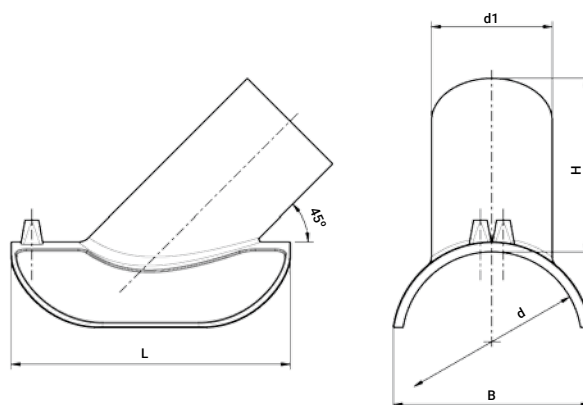

Product Code	Size d x d1	L	B	H	UC	W
4758A4160110	160-200 x 110	255	182	158	10	685
4758A4250110	225-315 x 110	255	221	158	10	710

* See dedicated tools on page 172 | * Ver herramientas necesarias en pag. 172

Wastewater Saddle PVC/PP Adaptor Inlet

4758V4

Collarín lightfit de transición para aguas residuales de PE A PP/PVC

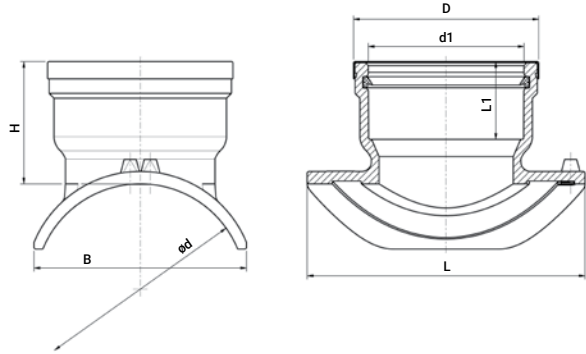

Product Code	Size d x d1	B	H	L	L1	D	UC	W
4758V4200160	200 x 160	208	125	290	80	190	6	1660
4758V4250160	225-250 x 160	225	125	290	80	190	6	1309
4758V4315160	280-315 x 160	245	125	290	80	190	6	1326
4758V4560160	355-560 x 160	263	125	290	80	190	6	1430
4758V4710160	560-710 x 160	277	125	290	80	190	6	1527

* See dedicated tools on page 172 | * Ver herramientas necesarias en pag. 172

Wastewater Saddle Spigot Inlet

4758S4

Titulo

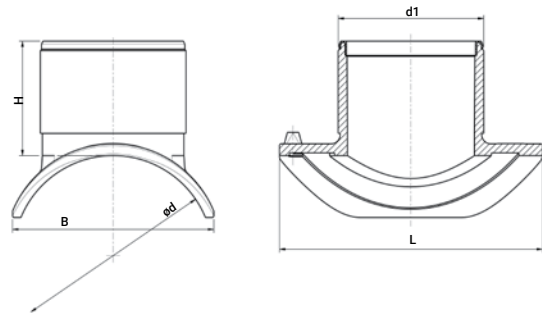

Product Code	Size d x d1	B	H	L	UC	W
4758S4200160	200 x 160	208	125	290	6	1091
4758S4250160	225 - 250 x 160	225	125	290	6	1239
4758S4315160	280 - 315 x 160	247	125	290	6	1260
4758S4560160	355 - 560 x 160	263	125	290	6	1300
4758S4710160	560 - 710 x 160	277	125	290	6	1310

* See dedicated tools on page 172 | * Ver herramientas necesarias en pag. 172

Wastewater Adjustable Elbow One Sided

4747D4

Codo Ajustable Para Aguas Residuales

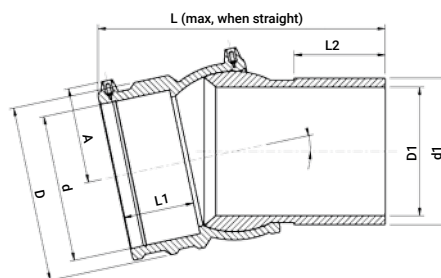

Product Code	Size d	SDR	D	D1	L	L1	L2	A	UC	W
4747D4160	160	17	193	141	298	78	98	105	6	3030

Wastewater Manhole Adaptor

37020/477207*

Adaptador Para Pozo de Aguas Residuales

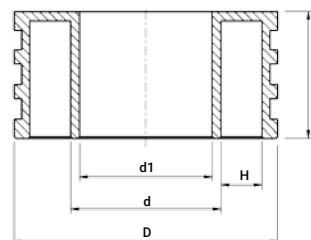

Product Code	Size d	L	d1	D	H	UC	W
37020110	110	135	97	216	37	—	1650
37020125	125	135	111	235	39	—	1800
37020140	140	135	123	254	39	—	1950
477207160	160*	135	141	280	39	6	2524
37020180	180	135	157	335	66	4	3550
37020200	200	135	176	355	56	2	3660
477207225	225*	135	198	355	44	2	3902
37020250	250	135	220	400	54	2	3740
477207280	280*	135	247	400	39	2	5027
37020315	315	135	278	450	46	2	5130
37020355	355	135	313	500	50	2	6480
37020400	400	135	353	560	59	1	8260
37020450	450	135	397	592	50	—	22350
37020500	500	135	441	651	54	—	23600
37020560	560	135	494	705	51	—	34500
37020630	630	135	555	773	50	—	47370

Wastewater PE to PVC Adaptor

4701V4

Adaptador Para PE A PVC

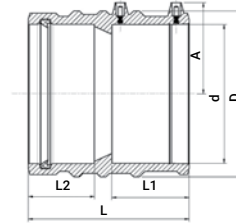

Product Code	Size d	L	L1	L2	D	A	UC	W
4701V4160	160	187	90	77	193	106	1546	6

Wastewater Adjustable Elbow PE to PVC

4747V4

Codo Ajustable de Transicion de PE a PVC

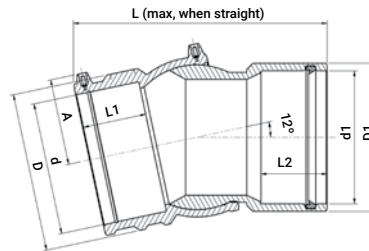

Product Code	Size d x d1	D	D1	L	L1	L2	A	UC	W
4747V4160	160 x 160	193	180	253	78	80	105	6	2140

Wastewater Elbow 45°

470604

Codo 45° Para Aguas Residuales

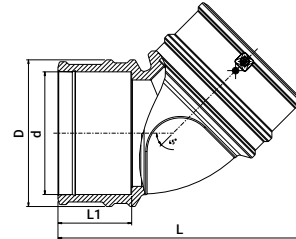

Product Code	Size d	L	L1	D	A	UC	W
470604160	160	325	98	193	106	—	1976

Wastewater Elbow 30°

473304

Codo 30° Para Aguas Residuales

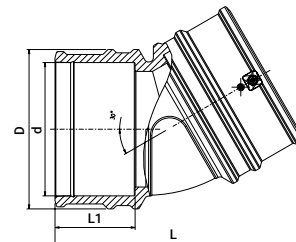

Product Code	Size d	L	L1	D	A	UC	W
473304160	160	302	98	193	106	—	1798

Wastewater Elbow 15°

473704

Codo 15° Para Aguas Residuales

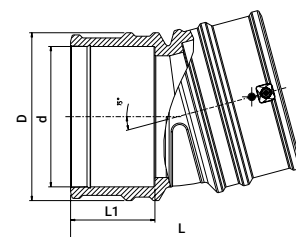

Product Code	Size d	L	L1	D	A	UC	W
473704160	160	267	98	193	106	—	1728

Technical Specifications

Technical Specifications for Plasson ElectroFusion Fittings

Fitting Pressure Rating and Pipe Compatibility

Plasson Fittings are weldable to PE80, PE100, PE100-RC and PE-X pipes (most fittings)*.

Check that the pipe SDR is compatible with the Plasson fittings.

The range of compatible pipe SDR's for each specific fitting is defined on the fitting barcode label.

For questions regarding pipe SDR compatibility refer to Plasson literature or contact your local Plasson representative.

* Please consult your Plasson representative

The following is a general guideline for Plasson EF product pipe SDR compatibility (in any case of discrepancy between the figure below and the figure on the barcode label, always refer to the barcode data).

Plasson's ElectroFusion Fittings:

- PN 16 (Water)
- PE100 SDR11 (Gas)
- Up to 75mm (inclusive) are Weldable to Pipes SDR ≤ 11
- Elbows and Tees of main diameter 40mm-75mm ≤ 17
- 90mm & Up are Weldable to Pipes SDR ≤ 17
- 63-75mm Tapping Saddles and Valves are suitable for SDR11

Note: for tapping SDR ≤ 11 pipes (size 63 and up), please consult your Plasson representative.

LightFit:

- PN 10 (Water)
- PE100 SDR17 (Gas)
- 40mm - 75mm are Weldable to Pipes SDR ≤ 17
- 90mm are Weldable to Pipes SDR ≤ 26
- 110mm - 800mm are Weldable to Pipes SDR ≤ 33

Wastewater Saddle

- PN 0.5 (Water)
- 200mm & Up are Weldable to Pipes SDR ≤ 26

Wastewater Adjustable Elbow

- PN 0.5 (Water)
- 160mm is Weldable to Pipes SDR ≤ 17

Measure the pipe external diameter toward the pipe end using a Pi tape. The pipe external diameter must be within the tolerances defined in International standards such as ISO 4437-2, AS/NZS, 4130, EN 1555-2 and EN 12201-2.

Material

All Plasson ElectroFusion fittings are produced from material class PE100 which conform to international standards for potable water and natural or suitable manufactured gas systems.

Standards

Plasson ElectroFusion fittings are designed, tested and quality controlled according to Plasson's internal standards. These standards are based on the following international standards:

- EN 1555
- EN 12201
- NF 136
- AS/NZS 4129
- WIS 4-32-14
- WIS 4-32-15

Quality

Plasson has incorporated a quality assurance system in accordance with ISO 9001. Operating approval according to ISO 9001 was granted to Plasson by the Israeli Standard Institute. Operating according to the ISO 9001 quality assurance system imposes stringent standards of control throughout the manufacturing processes.

Abbreviations used on the product description pages of this catalog:

A, A1	Height of shroud from centerline	L, L1, L2	Length
d, d1	Nominal diameter of fitting or outlet	c	Number of bolt holes in flanges
D, D1	Diameter	s	Diameter of bolt holes in flanges
DN	Nominal bore corresponding approximately to the inside diameter of the pipe	t	Thickness of metal flange
Dp	Pitch circle diameter of bolt holes in flanges	W	Weight in grams
G, R, Rp	Threaded outlet diameter	UC	Units per carton
H	Height	Fusion and cooling time are specified on the individual product.	

Whereas the products shown in this catalogue illustrate and describe the current state of their development, Plasson reserves the right at all times to make such technical alterations as it shall see fit to its products. Although every care has been taken in the preparation of the information, specifications and other data included in this catalogue, we cannot rule out inadvertent errors or omissions. Purchasers should take into account possible deviations or variations which will not substantially diminish the functionality or performance of the products, and, in many cases, are designed to improve the same.

Plasson® is the Registered Trademark of Plasson Ltd. or Plasson Maagan Michael Industries Ltd. Plasson's products are protected by patents, trademark, design and copyright laws.

Especificaciones técnicas para los accesorios ElectroFusion de Plasson

Presiones nominales y compatibilidad con la tubería

Los accesorios ElectroFusion de PLASSON se pueden soldar a tuberías de materiales PE80, PE100, PE100-RC, PE-X (la mayoría de los accesorios)*

Por favor revise que el SDR de la tubería es compatible con el rango declarado en el código de barras del accesorio Plasson. Cada accesorio Plasson contiene esta información.

Nota: para obtener más información sobre SDR de tuberías vea la información del fabricante de la tubería a soldar y literatura de Plasson. Ante cualquier duda consulte a su representante de Plasson

A continuación una guía general sobre la compatibilidad de accesorios Plasson según el SDR del tubo a electrofusionar. (En caso de existir alguna discrepancia por favor proceda según indica la calcomanía del accesorio que contiene el código de barras).

Presiones nominales

Las presiones nominales de todos los accesorios ElectroFusion de PLASSON son las siguientes:

- PN 16 (Agua)
- MOP10 (Gas)

Accesorios de ElectroFusión de Plasson

- Hasta 75mm (inclusive), soldables en tuberías SDR ≤ 11
- Codos y Tes en diámetros 40mm – 75mm ≤ 17
- De 90mm en adelante soldables en tuberías SDR ≤ 11
- De 63-75mm Tomas en carga y Válvulas soldables en tuberías SDR 11

NOTA: Para tuberías SDR ≤ 11 (diámetro desde 63mm hacia arriba) consulte a su representante de Plasson.

LightFit:

- PN10 (Agua)
- PE100 SDR 17 (GAS)
- 40mm - 75mm soldables en tuberías SDR ≤ 17
- 90mm soldables en tuberías SDR ≤ 26
- 110mm - 800mm soldables en tuberías SDR ≤ 33

Ramales de ElectroFusión Plasson para aguas residuales

- PN 0.5 (Agua)
- De 200mm en adelante en tuberías SDR ≤ 26

Codos ajustables de ElectroFusión para aguas residuales

- PN 0.5 (Agua)
- De 160mm en adelante en tuberías SDR ≤ 17

Para medir el diámetro externo de una tubería utilice una cinta PI. El diámetro externo debe estar contemplado dentro de las tolerancias estipuladas en las normas internacionales ISO 4437-2, AS/NZS.

Material

Todos los accesorios ElectroFusión de Plasson se fabrican con material de clase PE100, de conformidad con las normas internacionales para sistemas de agua potable y gas natural o procesado. Accesorios de PE80, disponibles a petición del cliente.

Normativa

El diseño, las pruebas y el control de calidad de los accesorios ElectroFusion de Plasson se llevan a cabo de acuerdo con las normas internas de Plasson, basadas en las siguientes normativas internacionales:

- EN 1555
- EN 12201
- NF 136
- AS/NZS 4129
- WIS 4-32-14
- WIS 4-32-15

Aseguramiento de Calidad

Plasson utiliza el sistema de aseguramiento de calidad conforme a la normativa ISO 9001. La certificación de la empresa de acuerdo con ISO 9001 le fue otorgada a Plasson por el Instituto Israelí de Normas Industriales. La operación conforme a la normativa de aseguramiento de calidad ISO 9001 impone estrictos procedimientos de control durante todos los procesos de fabricación.

Abreviaturas utilizadas en la descripción de productos de este catálogo:

A, A1	Altura desde la línea central a la cubierta del resistor	L, L1, L2	Longitud
d, d1	Diámetro nominal del accesorio o salida	c	Número de orificios en las bridas
D, D1	Diámetro	s	Diámetro de los orificios p/tornillos en las bridas
DN	Diámetro nominal interno, correspondiente aproximadamente al diámetro interno del tubo	t	Grosor de la brida metálica
Dp	Diámetro de los orificios en las bridas	W	Peso en gramos
G, R, Rp	Diámetro de la salida roscada	UC	Cantidad por caja de cartón
H	Altura	Los tiempos de soldadura y enfriamiento se indican en cada producto.	

Si bien en este catálogo se ilustran y describen los productos en el estado actual de su desarrollo, PLASSON se reserva el derecho de introducir en cualquier momento las modificaciones técnicas que considere convenientes.

La preparación de la información, especificaciones y otros datos se ha hecho con el mayor cuidado, no obstante lo cual no podemos asegurar que estén libres de errores u omisiones involuntarios. El cliente debe tener en cuenta la posibilidad de desviaciones o variaciones que no afectarán significativamente el funcionamiento o rendimiento de los productos y que, en muchos casos, están destinadas a mejorarlos.

Plasson™ es la marca registrada de Plasson Ltd. o Plasson Maagan Michael Industries Ltd.

Los productos de Plasson están protegidos por derechos de patente, marcas comerciales, diseño y leyes de copyright.

Controllers

The Smart Fuse System - Plasson ElectroFusion

Plasson offers quality tools and control boxes ensuring easy installation and safe, dependable connections.

All Plasson products combine to form the latest state-of-the art high performance pipe joining solution.

Plasson fittings include an automatic recognition system which is part of the complete Smart Fuse System.

The entire ElectroFusion process is executed and fully monitored by the computerized control box.

Plasson ElectroFusion fittings can be used with Plasson's computerized Smart Fuse System control box or with standard barcode systems.

Each Plasson ElectroFusion fitting comes complete with a barcode.

Plasson provides superior products and unmatched service based on over 50 years in the field.

For our complete tooling range please ask your local Plasson representative.

PLASSON Control Box product family includes the following features:

- Automatic (Smart Fuse System) welding for PLASSON ElectroFusion couplings up to 12 IPS
- Ergonomic design
- Fusion process supervision system
- Fully monitored welding process
- 4 x 20 alphanumeric character display with backlight and adjustable contrast
- Easy end user oriented data input
- Highly flexible welding cable
- Reduced service expense by software controlled calibration
- Easy data transfer to PC printer or portable memory box
- All controllers are equipped with bluetooth feature

PolyCode (USB + Bluetooth)

29143.0308S324

Control box for welding of small fittings

For all EF fittings up to 160mm*
mounted in plastic suitcase

Technical specifications

Output current	75 A (54 A peak current)
Welding voltage	8-48 V
Power supply	230 V (190-300 V) 16 A
Weight	11 kg
Dimensions	47x18x37 cm
Welding cable length	3 m
Data recording	1000 welding cycles, downloadable by USB memory stick
Display	4 lines alphanumeric display, available in 26 languages



Welding data input

Plasson "SmartFuse" automatic welding data input
Barcode reading (including temperature compensation)
Manual input of barcode digits

* At long welding cycles, cool down time equal to the welding time is required

PolyControl Plus (USB + Bluetooth) V2.0

29143.F0318V112

High power control box

Incorporates fan cooled electronic voltage converter
For continuous welding cycles of large fittings (no need for cool down)
For all EF fittings
Compact and lightweight aluminum casing

Technical specifications

Output current	85 A (110 A peak)
Welding voltage	8-48 V
Power supply	230 V (190-300 V) 16 A
Weight	15.5 kg
Dimensions	20x32x44 cm
Welding cable length	3 m
Data recording	1000 welding cycles, downloadable by USB memory stick
Display	4 lines alphanumeric display, available in 26 languages
Packaging	Flight case, size 50x42x39 cm, weight 8 kg



Welding data input

Plasson "SmartFuse" automatic welding data input
Barcode reading (including temperature compensation)
Manual input of barcode digits
Manual input of welding voltage and time

Polymatic Plus (USB + Bluetooth)

29143.0307.103

Universal control box

Incorporates fan cooled electronic voltage converter
 For continuous welding cycles of large fittings (no need for cool down)
 For all EF fittings
 Compact and lightweight aluminum casing



Technical specifications

Output current	75 A (110 A peak)
Welding voltage	8-48 V
Power supply	230 V (190-300 V) 16 A
Weight	18 kg
Dimensions	45x33x38 cm
Welding cable length	Detachable 5 m
Data recording	1000 welding cycles, downloadable by USB memory stick
Display	4 lines alphanumeric display, available in 26 languages
Packaging	Plastic case, size 47x44x38 cm, weight 4 kg

Welding data input

Plasson "SmartFuse" automatic welding data input
 Barcode reading (including temprature compensasion)
 Manual input of barcode digits
 Manual input of welding voltage and time

* At long welding cycles, cool down time equal to the welding time is required

Tiny Data MF (USB + Bluetooth)

29143.0308T108

Compact control box

For all EF fittings up to 400mm*
 Compact steel casing

Technical specifications

Output current	56 A (110 A peak current)
Welding voltage	8-48 V
Power supply	230 V (190-300 V) 16 A
Weight	16.5 kg
Dimensions	33x28x29 cm
Welding cable length	4 m
Data recording	1000 welding cycles, downloadable by USB memory stick
Display	4 lines alphanumeric display, available in 26 languages
Packaging	Wooden box, size 39x32x34 cm, weight 5.5 kg



Welding data input

Plasson "SmartFuse" automatic welding data input
 Barcode reading (including temprature compensation)
 Manual input of barcode digits
 Manual input of welding voltage and time

* At long welding cycles , cool down time equal to the welding time is required

Monomatic Data (USB + Bluetooth)

29143.0307.000

Dedicated controller for "SmartFuse" system

For Plasson "SmartFuse" fittings only, up to 400mm*
Durable steel and plastic casing

Technical specifications

Output current	56 A (110 A peak current)
Welding voltage	40 V
Power supply	230 V (190-300 V) 16 A, 50/60 Hz (40-70 Hz)
Weight	18 kg
Dimensions	45x33x38 cm
Welding cable length	Detachable 5 m
Data recording	500 welding cycles, downloadable by USB memory stick
Display	4 lines alphanumeric display, available in 26 languages
Packaging	Plastic case, size 47x44x38 cm, weight 4 kg



Welding data input

Plasson "SmartFuse" automatic reading

* At long welding cycles , cool down time equal to the welding time is required

ESPAÑOL

El sistema inteligente ElectroFusion de Plasson

Plasson ofrece herramientas y soldadoras automáticas de electrofusión de la más alta calidad, para facilitar la instalación y asegurar conexiones fiables.

Todos los productos de Plasson se combinan para brindar la solución más avanzada y eficiente de conexión de tuberías. Los accesorios de Plasson contienen un sistema de reconocimiento automático que forma parte de todo el sistema inteligente. La soldadora automática ejecuta y supervisa todo el proceso de electrofusión.

Los accesorios ElectroFusion de Plasson pueden utilizarse con la soldadora automática de Plasson, controlada por computadora, o con los sistemas estándar de código de barras.

Cada accesorio ("fitting") ElectroFusion de Plasson se entrega completo, con su propio código de barras.

Plasson se enorgullece de suministrar productos de excelente calidad y un servicio incomparable, respaldado por una experiencia de más de 50 años en el terreno.

Para obtener información sobre toda la línea de herramientas, consulte a su representante local de Plasson.

Soldadoras

La línea de soldadoras automáticas de PLASSON tiene las siguientes características:

- Soldadura automática para los enlaces ("cuplas") ElectroFusion de PLASSON hasta 12 IPS
- Diseño ergonómico
- Sistema de supervisión del proceso de electrofusión
- Soldadura totalmente monitorizada
- Pantalla de 4 x 20 caracteres alfanuméricos con iluminación de fondo y contraste ajustable
- Entrada de datos fácil y cómoda para el usuario
- Cable de soldadura altamente flexible
- Ahorro en costos de servicio gracias a la calibración controlada por software
- Facilidad en la transferencia de datos a PC, impresora o dispositivo de memoria portátil

PolyCode (USB + Bluetooth)

29143.0308S324

Entrada parámetros de soldadura

Máquina de Electrofusión Universal para accesorios hasta 160 mm

La máquina de electrofusión tipo PolyCode (USB) incorpora los siguientes procedimientos para incorporar los parámetros de soldadura:



Soldadura modo código de barras ISO/TR 13950, TIPO 2/5i, 24 dígitos)

El código de barras incorporado en la mayoría de los accesorios electrosoldables del mercado contiene todos los datos necesarios para la realización de la soldadura por electrofusión. Después de leer el código de barras con el dispositivo correcto, el proceso de recogida de datos es realizado automáticamente por la máquina de electrofusión. El código de barras contiene principalmente la siguiente información: Fabricante, tipo, diámetro, voltaje de fusión, tiempo de fusión (con la compensación de Temperatura, si es necesario), resistencia y tolerancia de la resistencia.

Soldadura modo automático SmartFuse

Mediante la lectura de la resistencia de referencia colocada en el pin de los accesorios electrosoldables SmartFuse, la unidad de control aplica automáticamente los datos de soldadura del accesorio.

Entrada manual del código de barras (los dígitos)

Si el código de barras del accesorio o el dispositivo de lectura tienen algún defecto, es posible entrar los números del código de barras del accesorio (si son visibles) manual mente en la máquina de electrofusión.

Especificaciones técnicas

Voltaje salida (soldadura)	8 - 48 AC
Rango Voltaje (nominal)	230 V (190-300 V) 16 A
Peso de transporte	11 Kilos
Medidas de embalaje	47x18x37 cm
Longitud cable soldadura	3 metros
Ingreso y lectura de datos de soldadura	"Smart Fuse" de Plasson que incluye compensación de temperatura, lectura de código barras con scanner, ingreso manual del código de barras (los dígitos)
Memoria de datos	Hasta 1,000 ciclos. Contiene puerto USB para bajar los datos registrados
Pantalla	4 líneas alfanuméricas en 26 idiomas

PolyControl Plus (USB + Bluetooth) V2.0

29143.F0318V112

Soldadora universal

Rango de aplicación

Las soldadoras de electrofusión del tipo PolyControl Plus (USB) V2.0 están exclusivamente destinadas a la soldadura de tubos termoplásticos (o sea de PE-HD, PE80, PE100 o PP) con accesorios de menos de 48V en su voltaje de entrada.

Estos dispositivos cumplen las especificaciones de las normativas DVS 2208-1 e ISO-12176-2, de las cuales derivan las normas aplicables a los equipos de electrofusión.



Rango de dimensiones

El rango de dimensiones de los accesorios para los cuales puede utilizarse una soldadora depende en primer lugar del consumo de energía de los accesorios. Dado que el consumo no es uniforme para todos los fabricantes, no es posible generalizar, y en caso de duda, es preciso examinar cada accesorio por separado. Para las soldadoras del tipo PolyControl Plus (USB) V2.0, y suponiendo que todas las operaciones de soldadura se realizan en secuencia, es decir que la soldadora tiene tiempo para enfriarse mientras se prepara el accesorio siguiente, se podría emitir la siguiente declaración general:

Utilizable sin limitaciones para todas las dimensiones de accesorios con hasta 85 A de consumo permanente de corriente. Todo lo dicho se refiere al trabajo con una temperatura ambiente de 20°C.

Nota: Si el ventilador de la parte trasera de la soldadora no está funcionando, el rango de tamaños se reduce a lo siguiente: hasta 250mm sin limitaciones, de 280 a 400mm con periodos de enfriamiento. No debe utilizarse la soldadora sin el ventilador para tamaños de más de 400mm a fin de evitar que el dispositivo resulte dañado.

Especificaciones técnicas

3F0218V112

PolyControl Plus (USB) V2.0

General

Tensión de salida	8 a 48 DC [V]
Registro de datos	Sí
Potencia (60% del tiempo ON) conformidad con ISO 12176-2	3600 W (100 A)
Rango de temperaturas	-10 a +50 [°C]
Protección	IP54
Clase de aplicación	1
Conformidad con	CE
Clase ISO 12176-2 - clasificación	P ₂ 4 U S ₁ V AK D X

Entrada de parámetros de soldadura

Código de barras con lector (escaneo opcional)	Sí
SmartFuse/(FUSAMATIC)	Sí
Entrada manual del código del accesorio	Sí
Entrada manual de parámetros de soldadura	Sí, U _{OUT} : 8 a 48 V, twELD: 0 a 9999 s
Entrada manual de parámetros de soldadura	No, U _{OUT} : 48V (prefijado), twELD: 0 a 9999 s

Entrada/Red eléctrica

Tensión	AC
Tensión nominal	230 [V]
Rango de tensión nominal (tolerancia)	185 a 300 [V]
Frecuencia nominal	50 [Hz]
Rango de frecuencia nominal (Tolerancia)	40 a 70 [Hz]
Factor de potencia cos ϕ	1 - PFC (EN 61000-3-3)
Corriente nominal	16 [A]
Consumo eléctrico	3600 [VA]
Longitud del cable	4.5 [m]
Tipo de enchufe	Euro plug

Especificaciones técnicas

3F0218V112

PolyControl Plus (USB) V2.0

Salida

Tensión	DC
Tensión de salida	8 a 48 [V]
Corriente de salida (max.)	110 [A]
Corriente de salida (t → ∞)	85 [A]
Corriente de salida (min.)	2 [A]
Ajuste de energía	Compensación de temperatura, Compensación de inductividad
Longitud del cable de soldadura	3 [m]
Montaje del cable de soldadura	Fijo
Terminales de soldadura	4.0 [mm] (opcional 4.7 [mm])

Funciones de monitorización

Tensión de entrada	Corriente, Frecuencia
Tensión de salida	Corriente, Resistencia, Contacto, Cortocircuito
Otro	Sistema, Temperatura de trabajo, Servicio
Mensajes de error	Texto, Señal acústica

Caja

Material	Aluminio de fundición
Pantalla	4 x 20 caracteres (alfanuméricos), iluminación de fondo
Peso del producto (sin cable de soldadura)	11 [kg]
Peso del producto (cable de soldadura incluido)	15.5 [kg]
Dimensiones Long x An x Alt	220 x 317 x 435 [mm]

Registro de datos

La soldadora PolyControl Plus (USB) V2.0 proporciona el registro de datos de soldadura para unos 1000 ciclos y datos de rastreo de conformidad con la norma ISO-12176-4:

Embalaje

Tipo	Flightcase
Dimensiones	500 x 420 x 385 [mm]
Peso del embalaje	8 [kg]
Peso para el transporte	24 [kg]

Datos registrados

Datos de fusión	Tensión, corriente, consumo, duración del proceso (nominal y real) Hora, modo, resistencia, mensajes de error con 10 valores de tensión y corriente
Datos accesorio	Código de barras (ISO/TR 13950), Tipo, Dimensión, Fabricante
Datos del dispositivo	Nº de serie, Nº de inventario, Fecha del último servicio, Horas de trabajo, Configuración del sistema
Código de barras del operador	(PF o ISO 12176-3) identificación personal y acceso a entrada manual y configuración del sistema

Funciones de rastreo

Nº encargo (código del trabajo)	Max. 40 caracteres (alfanuméricos) por código de barras
Código operador	ISO-12176-3
Número Sold.	DVS 2207 / 2208
Código soldadura	ISO-TR 13950
Rastreo código accesorio	ISO-12176-4
Rastreo código tubo 1	ISO-12176-4
Rastreo código tubo 2	ISO-12176-4
Rastreo código 3 / Infotext	ISO-12176-4 / 40 caracteres

Ciclo de servicio conformidad con ISO 12176-2 a 30%, 60% y 100%, Duración test t = 60 minutos

Duración test 60 min	Potencia de salida a Uout = 36 V	Potencia de salida a Uout = 40 V	Corriente de salida Iout
30%	3960 W	4400 W	110 A
60%	3600 W	4000 W	100 A
100%	3240 W	3600 W	90 A

Polymatic Plus (USB + Bluetooth)

29143.0307.103

Rango de aplicación

Las soldadoras de electrofusión del tipo Polymatic Plus (USB) están exclusivamente destinadas a la soldadura de tubos termoplásticos (o sea de PE-HD, PE80, PE100 o PP) con accesorios de menos de 48V en su voltaje de entrada.

Estos dispositivos cumplen las especificaciones de las normativas DVS 2208-1 e ISO-12176-2, de las cuales derivan las normas aplicables a los equipos de electrofusión.



Rango de dimensiones

El rango de dimensiones de los accesorios para los cuales puede utilizarse una soldadora depende en primer lugar del consumo de energía de los accesorios. Dado que el consumo no es uniforme para todos los fabricantes, no es posible generalizar, y en caso de duda, es preciso examinar cada accesorio por separado. Para las soldadoras del tipo Polymatic Plus (USB), y suponiendo que todas las operaciones de soldadura se realizan en secuencia, es decir que la soldadora tiene tiempo para enfriarse mientras se prepara el accesorio siguiente, se podría emitir la siguiente declaración general:

Sin limitaciones para el uso con accesorios de 20 a 630mm. Al trabajar con dimensiones a partir de los 630mm se requieren periodos más prolongados de enfriamiento, porque de otro modo podría aparecer el mensaje de error "Device too hot" (Dispositivo recalentado). En tal caso será preciso dejar que el equipo se enfríe antes de volver a utilizarlo. Antes de procesar accesorios dentro de este rango de dimensiones es necesario comprobar que la demanda de corriente del accesorio no sobrepase constantemente la corriente de salida del dispositivo, y tener cuidado de no sobrepasar la corriente máxima de salida. Todo lo dicho se refiere al trabajo con una temperatura ambiente de 20°C.

Especificaciones técnicas

3_0206_103

Polymatic Plus (USB)

General

Tensión de salida	8 a 48 DC [V]
Registro de datos	Sí
Potencia (60% del tiempo ON) conformidad con ISO 12176-2	2600 W (72.5 A)
Rango de temperaturas	-10 a +50 [°C]
Protección	IP54
Clase de aplicación	1
Conformidad con	CE
Clase ISO 12176-2 - clasificación	P ₂ 4 U S ₁ V AK D X

Entrada de parámetros de soldadura

Código de barras con lector (escaneo opcional)	Sí
SmartFuse/(FUSAMATIC)	Sí
Entrada manual del código del accesorio	Sí
Entrada manual de parámetros de soldadura	Sí, U _{OUT} : 8 a 48 V, tWELD: 0 a 9999 s
Entrada manual de parámetros de soldadura	No, U _{OUT} : 48V (prefijado), tWELD: 0 a 9999 s

Entrada/Red eléctrica

Tensión	AC
Tensión nominal	230 [V]
Rango de tensión nominal (tolerancia)	185 a 300 [V]
Frecuencia nominal	50 [Hz]
Rango de frecuencia nominal (Tolerancia)	40 a 70 [Hz]
Factor de potencia cos ϕ	0.6 a 0.9 (control de desfase)
Corriente nominal	16 [A]
Consumo eléctrico	3600 [VA]
Longitud del cable	4.5 [m]
Tipo de enchufe	Euro plug

Especificaciones técnicas

3_0206_103

Polymatic Plus (USB)

Salida

Tensión	AC
Tensión de salida	8 a 48 [V]
Corriente de salida (max.)	110 [A]
Corriente de salida (t → ∞)	40 [A]
Corriente de salida (min.)	2 [A]
Ajuste de energía	Compensación de temperatura
Longitud del cable de soldadura	5 [m], otras longitudes a pedido
Montaje del cable de soldadura	Fijo
Terminales de soldadura	4 [mm]
Adaptadores opcionales para terminales	4 to 4.7 [mm]

Funciones de monitorización

Tensión de entrada	Corriente, Frecuencia
Tensión de salida	Corriente, Resistencia, Contacto, Cortocircuito
Otro	Sistema, Temperatura de trabajo, Servicio
Mensajes de error	Texto, Señal acústica

Caja

Material	Placa de acero con recubrimiento plástico
Pantalla	4 x 20 caracteres (alfanuméricos), iluminación de fondo
Peso del producto (sin cable de soldadura)	16 [kg]
Peso del producto (cable de soldadura incluido)	18 [kg]
Dimensiones Long x An x Alt	450 x 325 x 380 [mm]

Registro de datos

La soldadora Polymatic Plus (USB) proporciona el registro de datos de soldadura para 1000 ciclos.

Embalaje

Tipo	Flightcase
Dimensiones	500 x 420 x 385 [mm]
Peso del embalaje	8 [kg]
Peso para el transporte	24 [kg]

Datos registrados

Datos generales	Hora, fecha, número de informe, temperatura ambiente
Datos de fusión	Tensión, corriente, consumo, duración del proceso (nominal y real), Hora, modo, resistencia, mensajes de error con 10 valores de tensión y corriente
Datos accesorio	Código de barras (ISO/TR 13950), Tipo, Dimensión, Fabricante
Datos del dispositivo	Nº de serie, Nº de inventario, Fecha del último servicio, Horas de trabajo, Configuración del sistema
Código operador	(PF o ISO 12176-3) identificación personal y acceso a entrada manual y configuración del sistema

Funciones de rastreo

Código	Encargo y Nº (máximo 40 caracteres) ingreso por código de barras o manual
Código operador	ISO-1276-3
Número Sold.	DVS 2207 / 2208
Código soldadura	ISO-TR 13950
Rastreo código accesorio	ISO-12176-4
Rastreo código tubo 1	ISO-12176-4
Rastreo código tubo 2	ISO-12176-4
Rastreo código 3 / Infotext	ISO-12176-4 / 40 caracteres

Ciclo de servicio conformidad con ISO 12176-2 a 30%, 60% y 100%, Duración test t = 60 minutos

Duración test 60 min	Potencia de salida a U _{OUT} = 36 V	Potencia de salida a U _{OUT} = 40 V	Corriente de salida I _{OUT}
30%	3500 W	3900 W	97.3 A
60%	2600 W	2900 W	72.5 A
100%	2100 W	2350 W	58.4 A

Tiny Data MF (USB + Bluetooth)

29143.0308T108

Rango de aplicación

Las soldadoras de electrofusión del tipo Tiny MF (USB) están exclusivamente destinadas a la soldadura de tubos termoplásticos (o sea de PE-HD, PE80, PE100 o PP) con accesorios de menos de 48V en su voltaje de entrada.

Estos dispositivos cumplen las especificaciones de las normativas DVS 2208-1 e ISO-12176-2, de las cuales derivan las normas aplicables a los equipos de electrofusión.



Rango de dimensiones

El rango de dimensiones de los accesorios para los cuales puede utilizarse una soldadora depende en primer lugar del consumo de energía de los accesorios. Dado que el consumo no es uniforme para todos los fabricantes, no es posible generalizar, y en caso de duda, es preciso examinar cada accesorio por separado. Para las soldadoras del tipo Tiny MF (USB), y suponiendo que todas las operaciones de soldadura se realizan en secuencia, es decir que la soldadora tiene tiempo para enfriarse mientras se prepara el accesorio siguiente, se podría emitir la siguiente declaración general:

Sin limitaciones para el uso con accesorios de 20 a 355mm. Al trabajar con dimensiones a partir de los 400mm se requieren periodos más prolongados de enfriamiento, porque de otro modo podría aparecer el mensaje de error "Device too hot" (Dispositivo recalentado). En tal caso será preciso dejar que el equipo se enfríe antes de volver a utilizarlo. Antes de procesar accesorios dentro de este rango de dimensiones es necesario comprobar que la demanda de corriente del accesorio no sobrepase constantemente la corriente de salida del dispositivo, y tener cuidado de no sobrepasar la corriente máxima de salida. Todo lo dicho se refiere al trabajo con una temperatura ambiente de 20°C.

Especificaciones técnicas

3_0208T108

Tiny Data MF (USB)

General

Tensión de salida	8 a 48 DC
Registro de datos	Sí
Potencia (60% del tiempo ON) conformidad con ISO 12176-2	2050 W (55.9 A)
Rango de temperaturas	-10 a +50 [°C]
Protección	IP54
Clase de aplicación	1
Conformidad con	CE
Clase ISO 12176-2 - clasificación	P ₂ 3 U S ₁ V AK D X

Entrada de parámetros de soldadura

Código de barras con lector (escaneo opcional)	Sí
SmartFuse/(FUSAMATIC)	Sí
Entrada manual del código del accesorio	Sí
Entrada manual de parámetros de soldadura	Sí, U _{OUT} : 8 a 48 V, twELD: 0 a 9999 s
Entrada manual de parámetros de soldadura	No, U _{OUT} : 48V (prefijado), twELD: 0 a 9999 s

Entrada/Red eléctrica

Tensión	AC
Tensión nominal	230 [V]
Rango de tensión nominal (tolerancia)	185 a 300 [V]
Frecuencia nominal	50 [Hz]
Rango de frecuencia nominal (Tolerancia)	40 a 70 [Hz]
Factor de potencia cos ϕ	0.6 a 0.9 (control de desfase)
Corriente nominal	16 [A]
Consumo eléctrico	3200 [VA]
Longitud del cable	5 [m]
Tipo de enchufe	Euro plug

Especificaciones técnicas

3_0208T108

Tiny Data MF (USB)

Salida

Tensión	AC
Tensión de salida	8 a 48 [V]
Corriente de salida (max.)	110 [A]
Corriente de salida (t → ∞)	30 [A]
Corriente de salida (min.)	2 [A]
Ajuste de energía	Compensación de temperatura
Longitud del cable de soldadura	4 [m], otras longitudes a pedido
Montaje del cable de soldadura	Fijo
Terminales de soldadura	4.0 [mm] (opcional 4.7 [mm])

Funciones de monitorización

Tensión de entrada	Corriente, Frecuencia
Tensión de salida	Corriente, Resistencia, Contacto, Cortocircuito
Otro	Sistema, Temperatura de trabajo, Servicio
Mensajes de error	Texto, Señal acústica

Caja

Material	Placa de acero
Pantalla	4 x 20 caracteres (alfanuméricos), iluminación de fondo
Peso del producto (sin cable de soldadura)	14 [kg]
Peso del producto (cable de soldadura incluido)	16.5 [kg]
Dimensiones Long x An x Alt	325 x 275 x 290 [mm]

Registro de datos

La soldadora Tiny Data MF (USB) proporciona el registro de datos de soldadura para unos 1000 ciclos.

Embalaje

Tipo	Flightcase
Dimensiones	500 x 420 x 385 [mm]
Peso del embalaje	8 [kg]
Peso para el transporte	24 [kg]

Datos registrados

Datos generales	Hora, fecha, número de informe, temperatura ambiente
Datos de fusión	Tensión, corriente, consumo, duración del proceso (nominal y real), Hora, modo, resistencia, mensajes de error con 10 valores de tensión y corriente
Datos accesorio	Código de barras (ISO/TR 13950), Tipo, Dimensión, Fabricante
Datos del dispositivo	Nº de serie, Nº de inventario, Fecha del último servicio, Horas de trabajo, Configuración del sistema
Código operador	(PF o ISO 12176-3) identificación personal y acceso a la configuración del sistema

Funciones de rastreo

Código	Encargo y Nº (máximo 40 caracteres) ingreso por código de barras o manual
Código operador	ISO-1276-3
Número Sold.	DVS 2207 / 2208
Código soldadura	ISO-TR 13950
Rastreo código accesorio	ISO-12176-4
Rastreo código tubo 1	ISO-12176-4
Rastreo código tubo 2	ISO-12176-4
Rastreo código 3 / Infotext	ISO-12176-4 / 40 caracteres

Ciclo de servicio conformidad con ISO 12176-2 a 30%, 60% y 100%, Duración test t = 60 minutos

Duración test 60 min	Potencia de salida a U _{OUT} = 36 V	Potencia de salida a U _{OUT} = 40 V	Corriente de salida I _{OUT}
30%	2700 W	3000 W	74.1 A
60%	2050 W	2250 W	55.9 A
100%	1600 W	1800 W	44.7 A

Monomatic Data (USB + Bluetooth)

29143.0307.000

Soldadora automática SmartFuse

Rango de aplicación

Las soldadoras de electrofusión del tipo Monomatic Data (USB) están exclusivamente destinadas a la soldadura de tubos termoplásticos (o sea de PE-HD, PE80, PE100 o PP) con accesorios de menos de 48V en su voltaje de entrada.

Estos dispositivos cumplen las especificaciones de las normativas DVS 2208-1 e ISO-12176-2, de las cuales derivan las normas aplicables a los equipos de electrofusión.



Rango de dimensiones

El rango de dimensiones de los accesorios para los cuales puede utilizarse una soldadora depende en primer lugar del consumo de energía de los accesorios. Dado que el consumo no es uniforme para todos los fabricantes, no es posible generalizar, y en caso de duda, es preciso examinar cada accesorio por separado. Para las soldadoras del tipo Monomatic Data (USB), y suponiendo que todas las operaciones de soldadura se realizan en secuencia, es decir que la soldadora tiene tiempo para enfriarse mientras se prepara el accesorio siguiente, se podría emitir la siguiente declaración general:

Sin limitaciones para el uso con accesorios de 20 a 355mm. Al trabajar con dimensiones a partir de los 400mm se requieren periodos más prolongados de enfriamiento, porque de otro modo podría aparecer el mensaje de error "Device too hot" (Dispositivo recalentado). En tal caso será preciso dejar que el equipo se enfríe antes de volver a utilizarlo. Antes de procesar accesorios dentro de este rango de dimensiones es necesario comprobar que la demanda de corriente del accesorio no sobrepase constantemente la corriente de salida del dispositivo, y tener cuidado de no sobrepasar la corriente máxima de salida. Todo lo dicho se refiere al trabajo con una temperatura ambiente de 20°C.

Especificaciones técnicas

3_0206_000

Monomatic Data (USB)

General

Tensión de salida	40 AC [V]
Registro de datos	Sí
Potencia (60% del tiempo ON) conformidad con ISO 12176-2	2050 W (55.9 A)
Rango de temperaturas	-10 a +50 [°C]
Protección	IP54
Clase de aplicación	1
Conformidad con	CE
Clase ISO 12176-2 - clasificación	P ₂ 3 U S ₁ F A D M

Entrada de parámetros de soldadura

Código de barras con lector (escaneo opcional)	No
SmartFuse/(FUSAMATIC)	Sí
Entrada manual del código del accesorio	No
Entrada manual de parámetros de soldadura	No, U _{OUT} : 8 a 48 V, t _{WELD} : 0 a 9999 s
Entrada manual de parámetros de soldadura	No, U _{OUT} : 48V (prefijado), t _{WELD} : 0 a 9999 s

Entrada/Red eléctrica

Tensión	AC
Tensión nominal	230 [V]
Rango de tensión nominal (tolerancia)	185 a 300 [V]
Frecuencia nominal	50 [Hz]
Rango de frecuencia nominal (Tolerancia)	40 a 70 [Hz]
Factor de potencia cos ϕ	0.6 a 0.9 (control de desfase)
Corriente nominal	16 [A]
Consumo eléctrico	3600 [VA]
Longitud del cable	4.5 [m]
Tipo de enchufe	Euro plug

Especificaciones técnicas

3_0206_000

Monomatic Data (USB)

Salida

Tensión	AC
Tensión de salida	40 [V]
Corriente de salida (max.)	110 [A]
Corriente de salida (t → ∞)	30 [A]
Corriente de salida (min.)	2 [A]
Ajuste de energía	Ninguno
Longitud del cable de soldadura	5 [m], otras longitudes a pedido
Montaje del cable de soldadura	Fijo
Terminales de soldadura	4.0 [mm] (opcional 4.7 [mm])

Funciones de monitorización

Tensión de entrada	Corriente, Frecuencia
Tensión de salida	Corriente, Resistencia, Contacto, Cortocircuito
Otro	Otro sistema, Temperatura de trabajo, Servicio
Mensajes de error	Texto, Señal acústica

Caja

Material	Placa de acero con recubrimiento plástico
Pantalla	4 x 20 caracteres (alfanuméricos), iluminación de fondo
Peso del producto (sin cable de soldadura)	16 [kg]
Peso del producto (cable de soldadura incluido)	18 [kg]
Dimensiones Long x An x Alt	450 x 325 x 380 [mm]

Registro de datos

La soldadora Monomatic Data (USB) proporciona el registro de datos de soldadura para 250 ciclos.

Embalaje

Tipo	Flightcase
Dimensiones	500 x 420 x 385 [mm]
Peso del embalaje	8 [kg]
Peso para el transporte	24 [kg]

Datos registrados

Datos generales	Hora, fecha, número de informe, temperatura ambiente
Datos de fusión	Tensión, corriente, consumo, duración del proceso (nominal y real), Hora, modo, resistencia, mensajes de error con 10 valores de tensión y corriente
Datos del dispositivo	Nº de serie, Nº de inventario, Fecha del último servicio Horas de trabajo, Configuración del sistema

Ciclo de servicio conformidad con ISO 12176-2 a 30%, 60% y 100%, duración test t = 60 minutos

Duración test 60 min	Potencia de salida a Uout = 36 V	Potencia de salida a Uout = 40 V	Corriente de salida Iout
30%	2700 W	3000 W	74.1 A
60%	2050 W	2250 W	55.9 A
100%	1600 W	1800 W	44.7 A

Extension Key for Tapping Valve

Llave de Extensión para Toma de Servicio Con Válvula

49546010 | 0.8 - 1.1mm

49546020 | 1.0 - 1.4mm

49546030 | 1.2 - 1.8mm



Key for Tapping Saddle

Llave para Toma de Servicio

29202000 | 18cm



Hand Scrapers

Raspatubos Manual

29145.3002.001 | 1.1/2"

29145.3002.003 | 2.1/2"



Rotational Scraper Tools

Raspatubos Giratorios

29144.4200.001 | 20-63mm

29144.4200.031 | 20-125mm

29144.4200.032 | 63-225mm

29144.4200.033 | 90-315mm



29170160 | 50-160mm

29170315 | 75-315mm

29170710 | 355-710mm



29144.4200.009 | 250-800mm



Plasson Scraper Tool for Pipe Ends

Raspatubos Giratorio Plasson

- 29144.4200.015 | 62-200mm
- 29144.4200.027 | 90-315mm
- 29144.4200.016 | 180-400mm
- 2912450800 | 450-800mm



Pipe Cutter

Cortadores de Tubería

- 29145.3000.005 | 42mm



- 29145.3000.007 | 63mm, One-Hand Operation



- 29145.3000.001 | 63mm



Rotational Pipe Cutter (S-Type)

Cortador de Tubería Giratorio (Tipo S)

- 29145.3001.004 | 20-75mm
- 29145.3001.001 | 50-140mm
- 29145.3001.002 | 90-160mm



Rotational Pipe Cutters

Cortador de Tubería Giratorio

- 29144.4400.006 | 32-125mm
- 29144.4400.004 | 63-200mm
- 29144.4400.005 | 90-315mm



Pipe Clamping Tools

Herramientas de Sujeción de Tubos

29144.4300.006 | 20-63mm



29144.4300.001 | 32-110mm

29144.4300.002 | 110-225mm



29144.4300.021 | 250-630mm



29363180 | 63-180mm

29363110 | 63-110mm



Squeeze - Off Tools

Prensatubos

29144.4100.010 | 63mm SDR11, SDR17

29144.4100.003 | 75-200mm



Pipe Clamping Tools

Herramientas de Sujeción de Tubos

- 29145.3006.063 | 63mm
- 29145.3006.075 | 75mm
- 29145.3006.090 | 90mm
- 29145.3006.110 | 110mm
- 29145.3006.125 | 125mm
- 29145.3006.160 | 160mm
- 29145.3006.180 | 180mm
- 29145.3006.200 | 200mm
- 29145.3006.225 | 225mm
- 29600250 | 250mm



Detergents

Detergentes

- 29145.2000.001 | Tangit Detergent, 1 Liter



- 29145.2000.002 | 100 Cleaning Pads with Tangit



Markers

Marcadores

- 29145.3100.019 | Plasson Marking Pen, Silver, 10 pcs
- 29600003 | Plasson Marking Pen, Silver, 10 pcs



Rounding Tool

Redondeador hidráulico

29144.4702.000 | Rounding Tool 450-800 Hydraulic
Redondeador hidráulico 450-800



Tools for Wastewater Saddles (See Pages 146, 147)

Herramientas para enlaces para aguas residuales (ver páginas 146 y 147)

29144.4700.001 | Drilling And Clamping Tools (set) for Wastewater Branch Saddle 160mm
Juego de herramientas de perforación y sujeción para collarines de derivación para aguas residuales 160mm



29144.4703.001 | Cutting and Clamping Tools for 45° Wastewater Saddle 110mm
Herramientas de corte y sujeción para collarines de 45° para aguas residuales 110mm



Rotational Scraper Tools

Rascador giratorio para tuberías de PEAD

29144.4200.009 | 250-800mm
29144.4200.012 | 800-1200mm



Electrical Saddle Scraper

Rascador eléctrico para tuberías de PEAD

29144.4200.024 | 230V (Electrical Scraper)



Core Drill Kit for Plasson-Saddle Outlet

29144.4702.002 | 2"female, 3"ips/ 4"ips/ 4"dips with sds-max-adapter+suitcase+ pilot drill, sds plus



Drilling Machine

29144.4702.999 | Drilling machine (Metabo BE75-X3/230V) with modified 225Nm gear including hexagon bit and adapter for core cutter for use up to 250mm



Pressure Test Pump

29144.4701.005 | Pressure test pump with adapter for plasson large bore saddles



Hot Tapping Tool

29144.4705.001 | Hot tapping tool ISO Flange DN150 with 230V motor



Saddle Pressing Tool

29142.4701.066 | Pressing tool 225mm/SDR17 for Waste Water Saddle



Saddle Clamping Tool

29142.4701.226 | Clamping plate 225mm/SDR17 splitable, for Waste Water Saddle, PLASSON



Saddle Clamping Tool

29144.4701.315 | Saddle clamp 250-800mm splitable; Outlet 315mm; PLASSON; incl. pressing tool in suitcase



Saddle Pressing and Clamping Tools

Herramientas necesarias para la instalación de Collarines de derivación y transición de gran diámetro

29144.4701.003 | Split-able saddle clamp – complete kit including re-rounder, straps, ratchets, test tube cutter, clamping plates for outlets:
 2" threaded transition/90/flange DN80, 110, 125/ flange DN100, 160/flange DN150
 Juego completo de barras sujetadoras con bisagras incluye redondeador, 2 cinchas, 2 cremalleras de amarre, cortador de tubo de prueba de presión, plancha de barras sujetadores para collarines de salidas:
 2" transición roscada, 90mm, 110mm, 125mm, 160mm y salidas bridadas respectivamente



29144.4701.004 | Large bore splitable saddle clamp 10 ips a 32 ips/ complete kit include outlets 3"ips, 4"ips y 4"dips

29144.4701.250* | Split-able clamping plate for outlet 250/flange DN 250, including- re-rounding shell
 Juego completo de barras sujetadoras con bisagras para salidas de 250mm y bridado. Incluye redondeador metálico para la salida 250mm



29144.4701.400* | Split-able clamping plate for outlet 400/flange DN 400, including adaptor for center strap
 Juego completo de barras sujetadoras con bisagras para salidas de 400mm y bridado. Incluye cincha redondeadora y centralizadora para la salida 400mm y bridado



29144.4701.009 | Tensioning tools set for large branch saddles, outlets 180 to 400, including 3 straps, 3 ratchets, torque wrench
 Juego completo de cinchas de amarre, cremalleras y tensión para collarines de derivación con salidas desde 180mm a 400mm, incluye: 3 cinchas, 3 cremalleras de amarre y llave de torque



* Must be used in combination with tensioning tools set 29144.4701.009

Core cutters- for each outlet size

Brocas campana para cada diámetro

29144.4702.003 | Core cutters set including: SDS max core, SDS plus core, 13mm core, center pilot drill, cutters for outlets:
2" threaded transition, 90/flange DN80, 110, 125/ flange DN100, 160/flange DN150
Juego de brocas campana de corte. Incluye: SDS max core, SDS plus core, 13mm core, center pilot drill, Brocas para corte y perforación de salidas: broca 2" transición roscada, brocas campana para 90mm, 110mm, 125mm, 160mm y bridadas respectivamente



29144.4702.199 | Core cutter for outlet 250/ flange DN 250
Broca campana para salida 250/ bridado DN 250

29142.4704.196 | Core cutter for PLASSON-Saddle outlet 225mm/SDR17;
borehole: 196mm c/w SDS-MAX adapter

29142.4702.251 | Core cutter for PLASSON-Saddle outlet 315mm/SDR11;
borehole: 251mm c/w SDS-MAX adapter, center drill and transport box



29144.4702.319 | Core cutter for outlet 400/ flange DN 400
Broca campana para salida 400/ bridado DN 400



Minimum required Generator Output power

Potencia mínima requerida de un generador de energía eléctrica, Potencia de salida

Voltage- 240 V, frequency- 50Hz, 1 phase
Synchronized, recommended - Mechanically regulated.

Fitting size	Output power Mechanically controlled generator	Output power Electronically controlled generator
20-75mm	2.0 KVA	2.0 KVA
90-160mm	3.2 KVA	3.2 KVA
180-500mm	4.5 KVA	5.0 KVA
500mm and up	6.5 KVA	7.5 KVA

When operating at high altitudes, rated generator power drops 10% for each 1000 meters. Use larger generator accordingly.

Sea level	1000m	2000m	3000m
3.2 KVA	3.5 KVA	4.0 KVA	4.2 KVA
4.5 KVA	5.0 KVA	5.5 KVA	6.5 KVA
6.5 KVA	7.5 KVA	8.0 KVA	8.5 KVA

Voltaje- 240 V, frecuencia- 50Hz, 1 fase
Generador sincronizado, recomendable de regulación mecánica.

Diámetro de accesorios	Potencia de salida de regulación mecánica	Potencia de salida de regulación electrónica
20-75mm	2.0 KVA	2.0 KVA
90-160mm	3.2 KVA	3.2 KVA
180-500mm	4.5 KVA	5.0 KVA
500mm and up	6.5 KVA	7.5 KVA

Cuando trabaje en zonas altas o elevadas considere una caída de potencia del generador del orden del 10% cada 1,000 metros de altura. Calcular la potencia necesaria acorde a la altura en la que se llevara a cabo la obra.

Potencia: Reducción de potencia aproximada = 10% cada 1,000 metros sobre el nivel del mar. El operador debe considerar la potencia necesaria del generador de acuerdo a la altitud sobre el nivel del mar en la que va a trabajar.

Características de un generador a combustible:

En Plasson para el uso con máquinas de electrofusión consideramos optimo min. 5.5kW para uso a nivel del mar.

1,000 mts. sobre el nivel del mar : min 6.1kW

2,000 mts. sobre el nivel del mar : min 6.9kW

2,800 mts. sobre el nivel del mar : min. 7.6kW

3,000 mts. sobre el nivel del mar : min. 7.9kW

Power (on altitude) = 5.5kW / (1 - (altitude / 10000m)).

Extension power cable size

Cable alargador de alimentación

Cable length	Minimum cross-section
Up to 20 meters	1.5mm ²
20-50 meters	2.5mm ²
50-100 meters	4.0mm ²

Largo del cable	Grosor mínimo
Hasta 20 metros	1.5mm ²
20-50 metros	2.5mm ²
50-100 metros	4.0mm ²



The logo consists of a red square containing a white icon of a pipe with a fitting, followed by the word "PLASSON" in white, uppercase, sans-serif font.

PLASSON

SERIES 1 FITTINGS



Plasson Series 1

Plasson Series 1 - The new range of innovative fittings created by Plasson, market leader in design and manufacture of reliable fittings for polyethylene pipe systems.

Plasson Series 1 - Fittings provide dedicated solutions for connecting PE pipe to various other pipe materials, such as Copper, Polybutylene, PVC and PEX.

Plasson Series 1 - Push fittings are designed to withstand 16 bar pressure rating. Inserting the pipe up to the fitting stop creates both the seal and the grip on the pipe.

Plasson Series 1 - Compact and attractive design makes this fitting ideal for the plumbing market, where space is limited and appearance is crucial. Simplicity of assembly makes both the professional and occasional user's job easier while retaining the Plasson reliability.

The combination of Plasson's current fitting range and the new Series 1 fulfill the requirements of all markets for PE pipe connections and connections to other pipe materials.

Plasson Series 1 features and benefits include:

- Aesthetically designed product - gives a professional finish to the job
- Assembly tools not required - simple push fit assembly
- Compact size - can be assembled in confined spaces
- Instant seal and integrity of joint - captive seal and no nuts to tighten
- Full end load performance - no need to restrain joints
- Transition from PE to internal plumbing systems - Copper, PB, PVC and PEX accommodated in one fitting
- 50 year design life - provides total reliability
- Tamper resistant design - ensures system integrity
- Reduced stock shelf space

Technical Specifications

Materials

Compression Fittings

Body: Polypropylene, high grade copolymer

Nut: High Grade Polypropylene

Split Ring and Grip Ring: Acetal (POM)

Liner: Acetal (POM)

Seal: Nitrile rubber (NBR)

Reinforcing Ring: Stainless steel on all female offtakes from 1¼" up to 2"

Threaded Fittings

Body: Polypropylene, high grade copolymer

Reinforcing Ring: Stainless steel

Brass Threads: CW617

Operating Temperatures

The fittings are not to be used with hot water, although they withstand the same temperature as the polyethylene pipe itself.

The fittings will withstand sub-zero temperatures.

Chemical Resistance

Plasson fittings are supplied, as standard, with polyacetal split and grip rings and NBR seals which are suitable for water.

Operating Pressures and Quality Certificates

Plasson fittings sizes 20-63 are tested and approved for water according to ISO 17885 (replaced 14236) to PN16.

Threads

All threads conform to ISO - 7/1, BS 21, DIN 2999, NEN 3258, AS 1722 Part 1.

All external threads are tapered.

All internal threads are parallel.

Legend

UB	Units per bag
UC	Units per carton
W	Weight in grams

The units per bag which appear in the catalog are scheduled to gradually take effect during 2017 (5 per bag for fittings up to 32mm; loose in carton for larger fittings).

Until the changes come into effect, all fittings are delivered 1 per bag.

Note

Before installation, ensure that the end of the pipe to be inserted into the fitting is free of scratches and other imperfections and that both the pipe and the fitting itself are free of sand, mud, stones, etc. If fittings are reused, ensure that split ring and grip ring teeth are sharp and bite into the pipe, to avoid pullouts. If uncertain, replace the split ring and grip ring.

Pull out resistance of PVC Adaptors and Universal Adaptors has been approved by pressure testing UPVC/PP pipe assemblies at 25 bar operating pressure for at least 1 hour.

Note: We strongly recommend the use of PTFE tape in threaded connections.

For diameters 40mm and above, chamfering and lubrication of the pipe end will ease insertion (use silicone lubricant).

Plasson Series 1

1001

Page 188 | Coupler



17610

Page 188 | Universal Slip Repair Coupler



07990

Page 188 | Plasson Wrench
Llave Plasson



17610/1761Q

Page 189 | Slip Repair Coupler



1011

Page 189 | Reducing Coupler



1012

Page 189 | End Plug



1002

Page 190 | Male Adaptor



1003

Page 190 | Female Adaptor



1003G

Page 191 | Female Adaptor G Thread



1001C

Page 191 | Copper Pipe Adaptor



1002C

Page 191 | Copper Pipe Male Adaptor



1003C

Page 192 | Female Copper Adaptor



10017

Page 192 | Universal Adaptor



1001Q

Page 192 | PE to PVC Pipe Adaptor



1001QQ

Page 193 | Coupling for PVC Pipe



1001M

Page 193 | Coupler Metric to Imperial



1072

Page 194 | Male Adaptor with Threaded Brass Offtake



1073

Page 195 | Female Adaptor with Threaded Brass Offtake



1073G

Page 195 | Female Adaptor with Threaded G* Brass Offtake



1004

Page 196 | 90° Tee



1034

Page 196 | 90° Reducing Tee



1014

Page 197 | 90° Tee with Threaded Female Offtake



1005

Page 197 | 90° Elbow



1006

Page 198 | 45° Elbow



1075

Page 198 | Wall Plate Elbow



1051

Page 199 | 90° Reducing Elbow



1005M

Page 199 | 90° Elbow Metric to Imperial



1085

Page 200 | 90° Elbow with Threaded Male Offtake



1015

Page 200 | 90° Elbow with Threaded Female Offtake



1077

Page 201 | 90° Elbow with Threaded Brass Male Offtake



1076

Page 201 | 90° Elbow with Threaded Brass Female Offtake



03410

Page 202 | Compression Stoptap



0341C

Page 202 | Stoptap - Copper Pipe Adaptor



0358916

Page 202 | Free Nut Union for Water Meter



0358917

Page 203 | Free Nut Adaptor with Check Valve



10990

Page 203 | Plasson Series 1 Wrench



18960

Page 203

Chamfer Tool for PE Pipes
Herramienta para biselar



10004

Page 204

Nut



10002

Page 204

NBR O-Ring



10002D

Page 204

EPDM O-Ring



100029

Page 205

NBR Shaped Seal



10002D

Page 205

EPDM Shaped Seal



10003

Page 205

Split Ring



10008

Page 206

Grip Ring



1091Q

Page 206

PVC Pipe Adaptor Kit



10999

Page 206

Copper Pipe Adaptor Kit

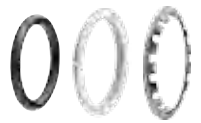

Page 207

Installation Instructions



Page 207

Disassembly



Page 208

Assembly Instructions
PVC Pipe Kit

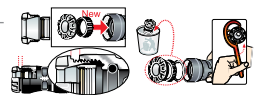

Page 209

Connection Instructions
PVC Pipe

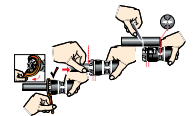



UNIVERSAL SLIP REPAIR COUPLING



**SLIDE
N'SEAL**
Pull-Out Resistant

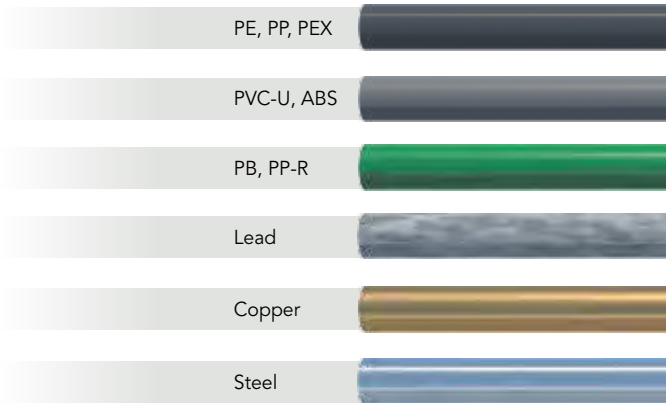

PN16	PN16	PN16	PN16	PN16
24-28 _{mm}	31-35 _{mm}	40-43 _{mm}	48-51 _{mm}	60-64 _{mm}
0.94"-1.1"	1.22"-1.37"	1.57"-1.69"	1.89"-2.00"	2.36"-2.52"

TYPICAL PIPES:

25 _{mm}	32 _{mm}	40 _{mm}	50 _{mm}	63 _{mm}
3/4"	1"	1.1/4"	1.1/2"	2"

- Suits a variety of plastic and metal pipe materials
- Each fitting designed to fit a wide range of diameters
- Zero force pipe insertion – can slide freely back and forth
- Thick o-ring seal – compensates for poor pipe quality
- Long sealing area – can bridge over damaged section or gap between pipes



*For further information regarding dimensions, suitable pipes and assembly instructions please scan the code.

Coupler

1001

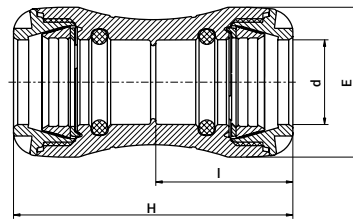

Product Code	Size d	E	H	I	UB	UC	W
100100020	20	41	92	45	1	260	64
100100025	25	47	98	48	1	200	80
100100032	32	58	108	53	1	120	126
100100040	40	70	142	70	1	90	256
100100050	50	85	158	78	1	55	369
100100063	63	103	183	90	1	30	620

Universal Slip Repair Coupler

NEW!

17610

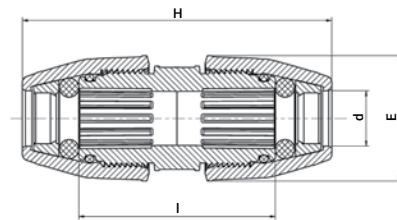

Product Code	Size d	E	H	I	UB	UC	W
176100024028	24-28	66	200	133	1	56	345
176100031035	31-35	76	210	143	1	40	467
176100040043	40-43	89	250	151	1	30	717
176100048051	48-51	101	270	158	1	20	968
176100060064	60-64	120	310	176	1	10	1517

Plasson Wrench

07990

Llave Plasson



Product Code	Size	UB	UC	W
07990001	16 - 40	—	250	65
07990005	40 - 75	—	75	296

Slip Repair Coupler

17610/1761Q*

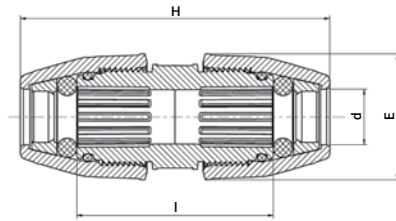

Product Code	Size d	E	H	I	UB	UC	W
1761Q0025	25	60	150	94	5	100	182
1761Q0032	32	68	160	96	5	80	238

* Split ring with metal teeth for wide range of plastic pipes

Reducing Coupler

1011

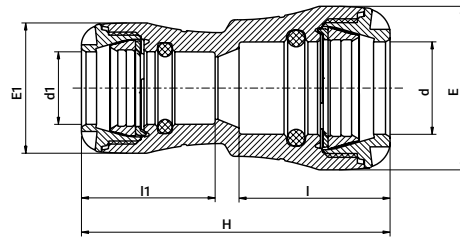

Product Code	Size d x d1	E	H	I	E1	I1	UB	UC	W
101100025020	25 x 20	47	100	48	41	45	1	200	75
101100032020	32 x 20	58	106	54	41	45	1	160	95
101100032025	32 x 25	58	110	54	47	48	1	160	109
101100040032	40 x 32	70	139	71	58	55	1	100	196
101100050025	50 x 25	85	151	79	47	46	1	80	262
101100050032	50 x 32	85	151	79	58	55	1	75	285
101100050040	50 x 40	85	165	77	58	53	1	65	326
101100063032	63 x 32	103	170	91	58	55	1	45	446
101100063040	63 x 40	103	184	91	70	72	1	40	485
101100063050	63 x 50	103	187	91	85	81	1	35	542

End Plug

1012

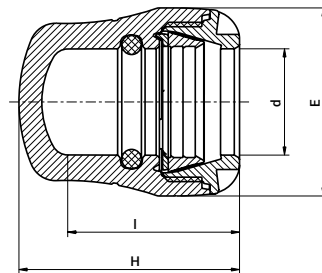

Product Code	Size d	E	H	I	UB	UC	W
101200020	20	41	56	45	1	360	39
101200025	25	47	60	48	1	300	50
101200032	32	58	68	53	1	220	82
101200040	40	70	90	71	1	150	146
101200050	50	85	102	79	1	100	229
101200063	63	103	117	91	1	55	379

Male Adaptor

1002

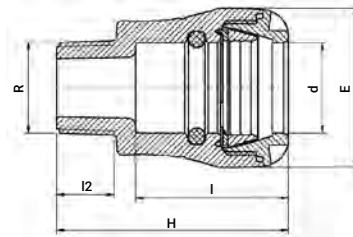

Product Code	Size d x R	E	H	I	I2	UB	UC	W
100200020005	20 x 1/2"	41	70	45	16	1	340	41
100200020007	20 x 3/4"	41	71	45	17	1	300	41
100200025005	25 x 1/2"	47	75	48	16	1	300	52
100200025007	25 x 3/4"	47	76	48	17	1	280	52
100200025010	25 x 1"	47	78	48	19	1	260	55
100200032007	32 x 3/4"	58	82	55	17	1	200	83
100200032010	32 x 1"	58	84	55	19	1	200	86
100200032013	32 x 1 1/4"	58	86	55	21	1	200	90
100200032015	32 x 1 1/2"	58	86	55	21	1	200	94
100200032020	32 x 2"	58	97	55	25	1	140	138
100200040010	40 x 1"	70	104	73	19	1	140	145
100200040013	40 x 1 1/4"	70	106	73	21	1	135	149
100200040015	40 x 1 1/2"	70	106	73	21	1	130	152
100200040020	40 x 2"	70	110	73	25	1	130	161
100200050010	50 x 1"	85	125	78	19	1	90	238
100200050013	50 x 1 1/4"	85	122	78	21	1	90	231
100200050015	50 x 1 1/2"	85	114	81	21	1	90	226
100200050020	50 x 2"	85	118	81	25	1	85	232
100200063015	63 x 1 1/2"	103	125	92	19	1	50	377
100200063020	63 x 2"	103	129	92	25	1	50	367

Female Adaptor

1003

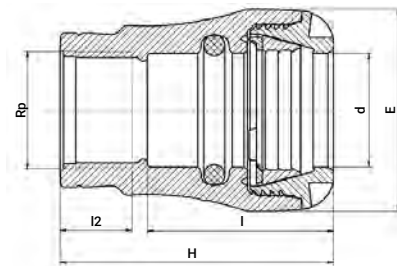

Product Code	Size d x Rp	E	H	I	I2	UB	UC	W
100300020005	20 x 1/2"	41	67	45	17	1	340	43
100300020007	20 x 3/4"	41	71	45	18	1	320	45
100300025005	25 x 1/2"	47	70	48	17	1	300	52
100300025007	25 x 3/4"	47	71	48	18	1	280	52
100300025010	25 x 1"	47	80	48	21	1	280	60
100300032007	32 x 3/4"	58	77	54	18	1	200	78
100300032010	32 x 1"	58	79	54	21	1	200	81
100300032013	32 x 1 1/4"	58	90	54	24	1	160	112
100300040010	40 x 1"	70	97	70	21	1	140	153
100300040013	40 x 1 1/4"	70	100	70	24	1	135	171
100300040015	40 x 1 1/2"	70	103	70	24	1	130	171
100300050013	50 x 1 1/4"	85	110	78	24	1	90	241
100300050015	50 x 1 1/2"	85	110	78	24	1	90	247
100300050020	50 x 2"	85	118	78	29	1	80	252
100300063015	63 x 1 1/2"	103	125	90	24	1	50	378
100300063020	63 x 2"	103	129	90	29	1	45	379

Female Adaptor G Thread

1003G

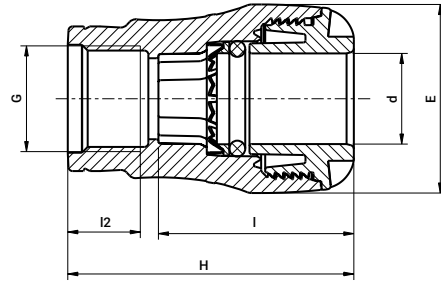

Product Code	Size d x G	H	E	I	I2	UB	UC	W
1003G0025007	25 x ¾"	71	47	48	12	1	280	52
1003G0025010	25 x 1"	80	47	48	14	1	260	60
1003G0032007	32 x ¾"	76	58	54	12	1	200	78
1003G0032010	32 x 1"	79	58	54	14	1	200	81
1003G0040015	40 x 1½"	103	70	70	19	1	130	176

Copper Pipe Adaptor

1001C

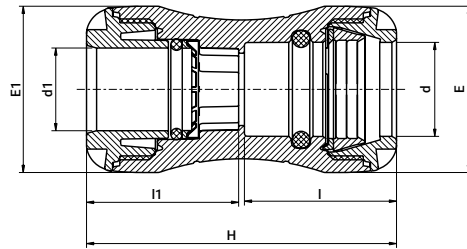

Product Code	Size d x d1	E	H	I	E1	I1	UB	UC	W
1001C0020015	20 x 15	41	92	45	41	45	1	260	68
1001C0025015	25 x 15	47	100	48	41	46	1	200	78
1001C0025022	25 x 22	47	98	48	47	48	1	180	81
1001C0032028	32 x 28	58	108	53	58	53	1	120	131
1001C0040028	40 x 28	70	139	71	58	55	1	120	203

Copper Pipe Male Adaptor

1002C

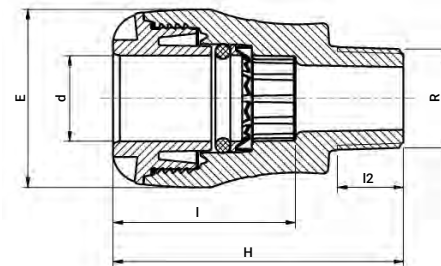

Product Code	Size d x R	E	H	I	I2	UB	UC	W
1002C7015007	15 x ¾"	41	71	45	17	1	350	44
1002C7015007	22 x ¾"	47	76	48	17	1	300	51
1002C7015007	28 x 1"	58	84	55	19	1	150	90

Female Copper Adaptor

1003C

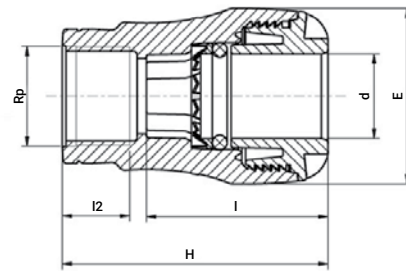

Product Code	Size d x Rp	H	E	I	I2	UB	UC	W
1003C7015007	15 x 3/4"	71	41	45	18	5	300	48
1003C7022007	22 x 3/4"	71	47	48	18	5	280	55

Universal Adaptor

10017

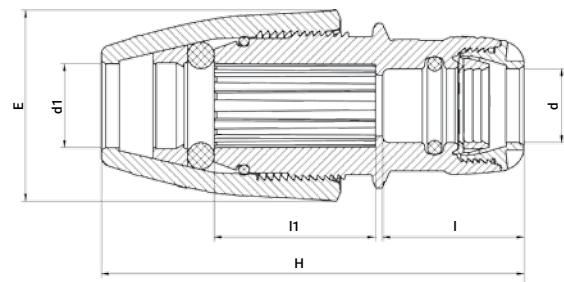

Product Code	Size d x d1	H	E	I	I1	UB	UC	W
100170025018	25 x 14-18	117-137	54	48	47	5	180	130
100170025022	25 x 19-22	119-130	57	48	47	5	150	141
100170025028	25 x 24-28	130-142	66	48	55	5	120	180

PE to PVC Pipe Adaptor

1001Q

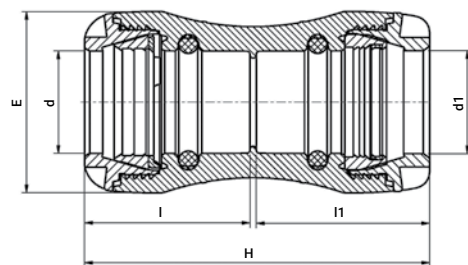

Product Code	Size d x d1*	H	E	I	I1	UB	UC	W
1001Q0025	25 x 25	100	47	48	50	1	160	85
1001Q0032	32 x 32	110	58	53	55	1	100	133
1001Q0040	40 x 40	145	70	70	73	1	100	249
1001Q0063	63 x 63	188	103	90	95	1	30	652

* d1 - PVC connection

Coupling for PVC Pipe

1001QQ

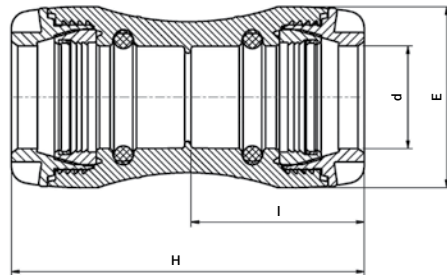

Product Code	Size d	H	E	I	UB	UC	W
1001QQ025	25	101	47	50	1	160	95
1001QQ032	32	112	70	55	1	100	144
1001QQ040	40	148	70	73	1	80	262
1001QQ063	63	193	103	95	1	30	683

Coupler Metric to Imperial (IPS)

1001M

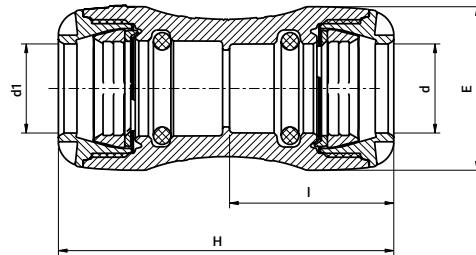

Product Code	Size d x d1	E	H	I	UB	UC	W
1001M6020005	20 x 1/2"	41	92	45	1	240	62
1001M6025005	25 x 1/2"	47	100	48	1	240	76
1001M6025007	25 x 3/4"	47	98	48	1	300	80
1001M6032010	32 x 1"	58	108	53	1	120	130

Male Adaptor with Threaded Brass Offtake

1072

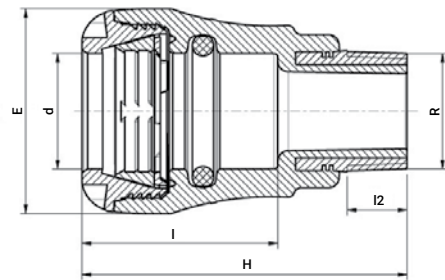

Product Code	Size d x R	E	H	I	I2	UB	UC	W
107200020005	20 x 1/2"	41	76	45	13	1	340	72
107200020007	20 x 3/4"	41	77	45	15	1	300	82
107200025005	25 x 1/2"	47	79	48	13	1	280	82
107200025007	25 x 3/4"	47	80	48	15	1	280	92
107200025010	25 x 1"	47	85	48	17	1	240	126
107200032007	32 x 3/4"	58	88	55	15	1	200	120
107200032010	32 x 1"	58	92	55	17	1	160	153
107200032013	32 x 1 1/4"	58	100	55	19	1	140	200
107200032015	32 x 1 1/2"	58	101	55	19	1	140	239
107200040010	40 x 1"	70	110	73	17	1	130	216
107200040013	40 x 1 1/4"	70	113	73	19	1	110	260
107200040015	40 x 1 1/2"	70	113	73	19	1	100	290
107200050010	50 x 1"	85	127	81	17	1	90	300
107200050013	50 x 1 1/4"	85	127	81	19	1	80	340
107200050015	50 x 1 1/2"	85	120	81	19	1	80	366
107200050020	50 x 2"	85	127	81	23	1	65	449
107200063015	63 x 1 1/2"	103	132	92	19	1	50	500
107200063020	63 x 2"	103	139	92	23	1	50	580

Female Adaptor with Threaded Brass Offtake

1073

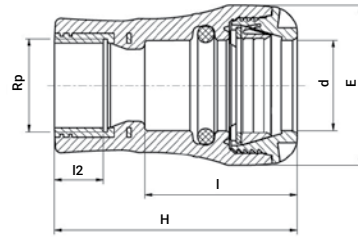

Product Code	Size d x Rp	E	H	I	I2	UB	UC	W
107300020005	20 x 1/2"	41	73	20	15	1	300	80
107300020007	20 x 3/4"	41	80	20	16	1	280	100
107300025005	25 x 1/2"	47	76	25	15	1	280	91
107300025007	25 x 3/4"	47	78	25	16	1	280	104
107300025010	25 x 1"	47	89	25	19	1	200	136
107300032007	32 x 3/4"	58	86	32	16	1	180	131
107300032010	32 x 1"	58	88	32	19	1	160	156
107300032013	32 x 1 1/4"	58	98	32	21	1	120	214
107300040007	40 x 3/4"	70	109	40	16	1	130	196
107300040010	40 x 1"	70	106	40	19	1	130	226
107300040013	40 x 1 1/4"	70	109	40	21	1	110	273
107300040015	40 x 1 1/2"	70	113	40	21	1	100	299
107300050010	50 x 1"	85	113	50	19	1	80	313
107300050013	50 x 1 1/4"	85	124	50	21	1	80	350
107300050015	50 x 1 1/2"	85	118	50	21	1	80	367
107300050020	50 x 2"	85	127	50	26	1	65	457
107300063015	63 x 1 1/2"	103	128	63	21	1	50	515
107300063020	63 x 2"	103	133	63	26	1	50	586

Female Adaptor with Threaded G* Brass Offtake

1073G

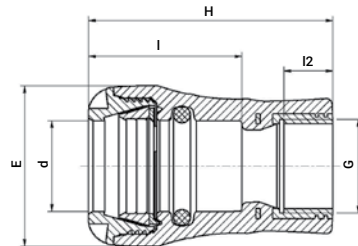

Product Code	Size d x G	H	E	I	I2	UB	UC	W
1073G0025007	25 x 3/4"	78	47	48	12	1	240	98
1073G0025010	25 x 1"	89	47	48	14	1	200	136
1073G0032007	32 x 3/4"	86	58	56	12	1	200	135
1073G0032010	32 x 1"	88	58	56	14	1	160	155
1073G0040013	40 x 1 1/4"	109	70	73	19	1	110	262

* For connecting parallel male thread

90° Tee

1004

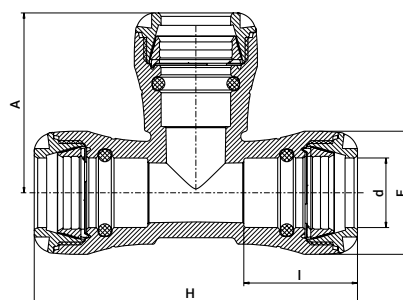

Product Code	Size d	E	H	A	I	UB	UC	W
100400020	20	41	123	71	45	1	140	103
100400025	25	47	134	78	48	1	100	137
100400032	32	58	152	84	54	1	60	221
100400040	40	70	192	108	70	1	45	429
100400050	50	85	214	124	78	1	30	667
100400063	63	103	262	147	90	1	14	1157

90° Reducing Tee

1034

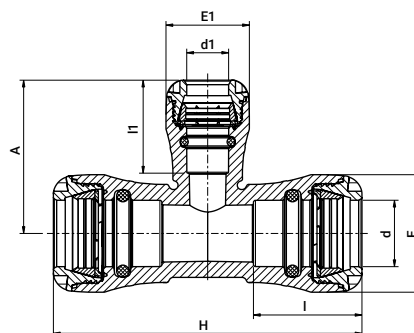

Product Code	Size d x d1 x d	H	A	E	E1	I	I1	UB	UC	W
103400025020	25 x 20 x 25	134	73	47	41	48	46	1	120	127
103400032020	32 x 20 x 32	152	75	58	41	54	46	1	80	185
103400032025	32 x 25 x 32	152	81	58	47	54	49	1	80	195
103400040025	40 x 25 x 40	192	86	70	47	70	49	1	55	325
103400040032	40 x 32 x 40	192	93	70	58	70	54	1	55	356
103400050025	50 x 25 x 50	214	90	85	47	78	49	1	35	500
103400050032	50 x 32 x 50	214	98	85	58	78	54	1	35	530
103400063025	63 x 25 x 63	262	96	103	47	90	49	1	24	848
103400063032	63 x 32 x 63	262	100	103	58	90	54	1	20	871

90° Tee with Threaded Female Offtake

1014

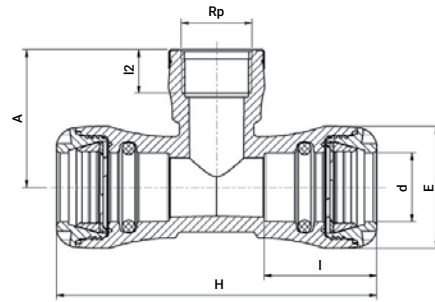

Product Code	Size d x Rp	E	H	A	I	I2	UB	UC	W
101400020005	20 x 1/2"	41	123	43	45	17	1	200	84
101400020007	20 x 3/4"	41	123	46	45	18	1	180	88
101400020010	20 x 1"	41	123	52	45	21	1	180	99
101400025005	25 x 1/2"	47	134	46	48	17	1	140	105
101400025007	25 x 3/4"	47	134	46	48	18	1	140	107
101400025010	25 x 1"	47	134	54	48	21	1	140	114
101400032007	32 x 3/4"	58	152	52	54	18	1	80	172
101400032010	32 x 1"	58	152	55	54	21	1	80	183
101400032013	32 x 1 1/4"	58	152	63	54	24	1	60	215

90° Elbow

1005

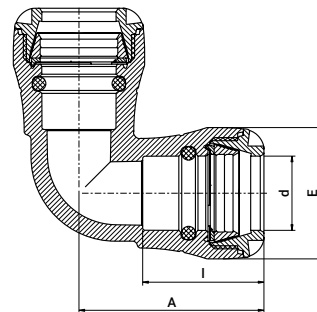

Product Code	Size d	E	A	I	UB	UC	W
100500020	20	41	67	45	1	200	75
100500025	25	47	73	48	1	160	96
100500032	32	58	81	54	1	100	157
100500040	40	70	106	70	1	65	291
100500050	50	85	119	78	1	40	462
100500063	63	103	141	90	1	25	799

45° Elbow

1006

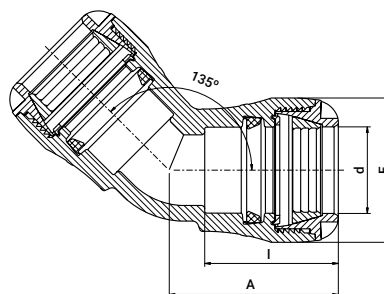

Product Code	Size d	E	I	A	UB	UC	W
100600032	32	58	54	67	1	120	147
100600040	40	70	71	88	1	80	263
100600050	50	85	79	100	1	40	428
100600063	63	103	90	118	1	25	719

Wall Plate Elbow

1075

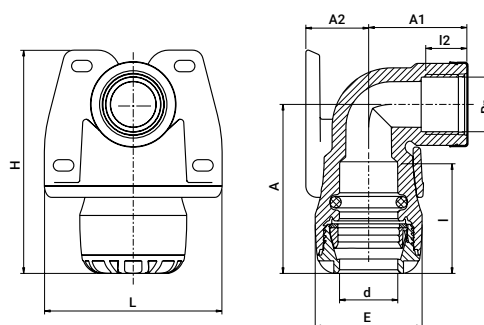

Product Code	Size d x Rp	E	I	I2	A	A1	A2	L	H	UB	UC	W
107500020005	20 x 1/2"	41	45	17	67	39	28	73	95	1	160	92
107500020007	20 x 3/4"	41	45	18	67	43	28	73	95	1	160	96
107500025005	25 x 1/2"	47	48	17	74	40	28	78	98	1	140	110
107500025007	25 x 3/4"	47	48	18	74	43	28	78	98	1	140	116

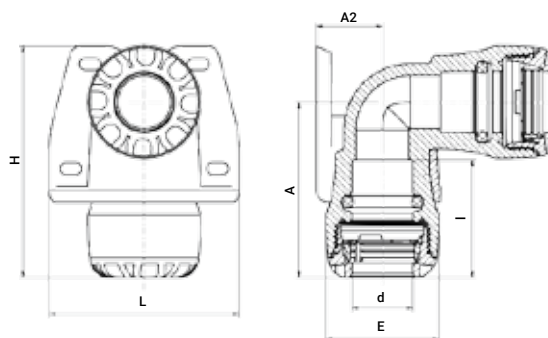

Product Code	Size d x d	E	I	A	A2	L	H	UB	UC	W
107500025	25 x 25	47	48	74	28	78	98	5	125	138

90° Reducing Elbow

1051

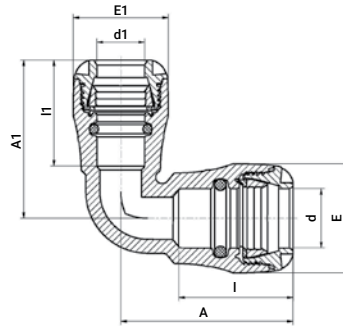

Product Code	Size d x d1	A	E	I	A1	E1	I1	UB	UC	W
105100025020	25 x 20	74	47	48	68	41	46	1	160	90

90° Elbow Metric to Imperial (IPS)

1005M

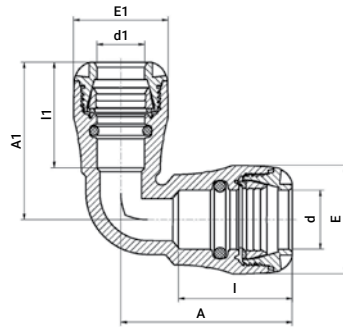

Product Code	Size d x d1	A	E	I	A1	E1	I1	UB	UC	W
1005M6025005	25 x 1/2"	74	47	48	68	41	46	5	180	89
1005M6025007	25 x 3/4"	73	47	48	73	47	48	5	160	101

90° Elbow with Threaded Male Offtake

1085

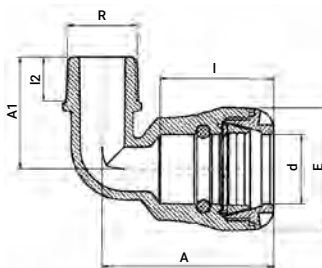

Product Code	Size d x R	E	A	I	A1	I2	UB	UC	W
108500020005	20 x 1/2"	41	66	45	41	16	1	300	47
108500020007	20 x 3/4"	41	66	45	42	17	1	300	52
108500025005	25 x 1/2"	47	74	48	44	16	1	290	57
108500025007	25 x 3/4"	47	74	48	45	17	1	250	64
108500025010	25 x 1"	47	74	48	47	19	1	220	65
108500032007	32 x 3/4"	58	81	53	51	17	1	190	90
108500032010	32 x 1"	58	81	53	53	19	1	180	92
108500032013	32 x 1 1/4"	58	81	53	54	21	1	150	114
108500040010	40 x 1"	70	107	71	57	19	1	110	173
108500040013	40 x 1 1/4"	70	107	71	58	21	1	100	189
108500040015	40 x 1 1/2"	70	107	71	60	21	1	100	194
108500050013	50 x 1 1/4"	85	122	79	68	22	1	65	275
108500050015	50 x 1 1/2"	85	122	79	68	21	1	65	290
108500063013	63 x 1 1/4"	103	143	90	76	22	1	40	445
108500063015	63 x 1 1/2"	103	143	90	78	21	1	40	458
108500063020	63 x 2"	103	143	90	81	25	1	40	492

90° Elbow with Threaded Female Offtake

1015

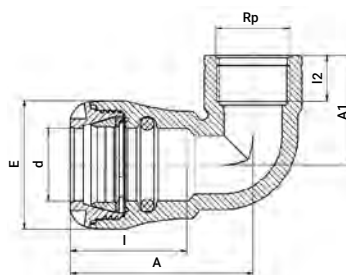

Product Code	Size d x Rp	E	I	A	A1	I2	UB	UC	W
101500020005	20 x 1/2"	41	45	67	39	17	1	240	51
101500020007	20 x 3/4"	41	45	67	43	18	1	240	55
101500020010	20 x 1"	41	45	67	49	21	1	240	64
101500025005	25 x 1/2"	47	48	74	40	17	1	220	63
101500025007	25 x 3/4"	47	48	74	43	18	1	200	70
101500025010	25 x 1"	47	48	74	50	21	1	180	82
101500032007	32 x 3/4"	58	54	83	45	18	1	180	95
101500032010	32 x 1"	58	54	83	49	21	1	160	111
101500032013	32 x 1 1/4"	58	54	83	60	24	1	120	145
101500040010	40 x 1"	70	72	107	51	21	1	110	179
101500040013	40 x 1 1/4"	70	72	107	61	24	1	100	226
101500040015	40 x 1 1/2"	70	72	107	65	24	1	90	244
101500050015	50 x 1 1/2"	85	79	119	63	24	1	60	330
101500050020	50 x 2"	85	79	119	75	29	1	55	349
101500063020	63 x 2"	103	79	141	70	29	1	35	534

90° Elbow with Threaded Brass Male Offtake

1077

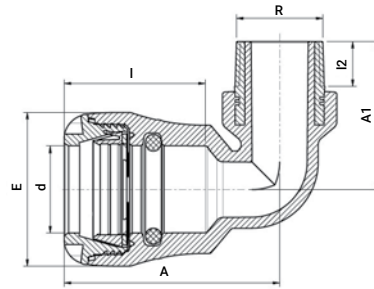

Product Code	Size d x R	E	I	A	A1	I2	UB	UC	W
107700032007	32 x ¾"	58	53	81	80	15	5	120	239
107700032010	32 x 1"	58	53	81	83	17	5	120	172
107700032013	32 x 1¼"	58	53	81	83	19	5	120	284
107700032015	32 x 1½"	58	53	81	83	19	5	120	305
107700040010	40 x 1"	70	59	104	71	17	1	90	239
107700040013	40 x 1¼"	70	59	104	71	19	1	90	295
107700040015	40 x 1½"	70	59	104	71	19	1	85	341
107700050010	50 x 1"	85	79	116	62	19	1	70	337
107700050013	50 x 1¼"	85	79	116	68	21	1	70	384
107700050015	50 x 1½"	85	79	116	73	21	1	50	431
107700050020	50 x 2"	85	79	116	85	23	1	50	549
107700063013	63 x 1¼"	103	90	134	74	21	1	30	559
107700063015	63 x 1½"	103	90	134	74	21	1	40	588
107700063020	63 x 2"	103	90	134	85	26	1	40	726

90° Elbow with Threaded Brass Female Offtake

1076

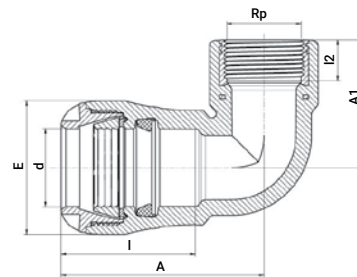

Product Code	Size d x Rp	E	I	A	A1	I2	UB	UC	W
107600032010	32 x 1"	58	53	73	60	19	1	140	187
107600040007	40 x ¾"	70	72	107	51	16	1	250	219
107600040010	40 x 1"	70	72	107	60	19	1	90	252
107600040013	40 x 1¼"	70	72	107	67	21	1	90	313
107600040015	40 x 1½"	70	72	107	70	21	1	85	355
107600050010	50 x 1"	85	79	122	60	19	1	70	349
107600050013	50 x 1¼"	85	79	122	67	21	1	60	403
107600050015	50 x 1½"	85	79	122	73	21	1	60	455
107600050020	50 x 2"	85	79	122	84	26	1	50	558
107600063013	63 x 1¼"	103	90	143	68	21	1	40	575
107600063015	63 x 1½"	103	90	143	72	21	1	40	621
107600063020	63 x 2"	103	90	143	82	26	1	40	747

Compression Stoptap

03410

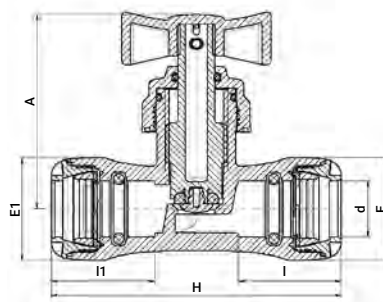

Product Code	Size d x d	H	A	E	I	E1	I1	UB	UC	W
034100020	20 x 20	123	89	41	45	—	—	1	100	145
034100025	25 x 25	134	89	47	48	—	—	1	100	167
034100025020	25 x 20	129	89	47	48	42	45	1	100	161
034100032	32 x 32	152	89	58	54	—	—	1	80	225

Stoptap - Copper Pipe Adaptor

0341C

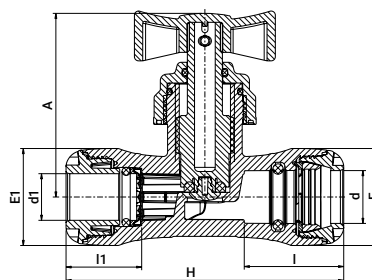

Product Code	Size d x d1	H	A	E	E1	I	I1	UB	UC	W
0341C0020015	20 x 15	123	89	41	41	45	45	1	100	149
0341C0025015	25 x 15	129	89	47	42	48	46	1	100	165
0341C0025022	25 x 22	134	89	47	47	48	48	1	100	171
0341C0032028	32 x 28	159	89	58	58	54	54	1	80	223

Free Nut Union for Water Meter

0358916

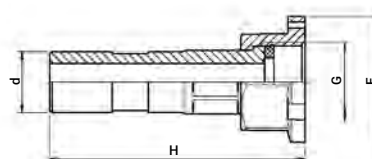

Product Code	Size d x G	E	H	UB	UC	W
0358916020	20 x 3/4"	42	86	1	150	37
0358916025	25 x 1"	50	90	1	150	53

Free Nut Adaptor with Check Valve

0358917

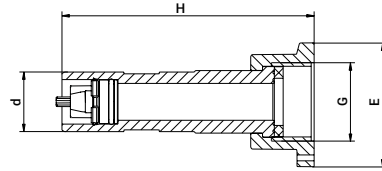

Product Code	Size d x G	E	H	UB	UC	W
0358917020	20 x ¾"	44	86	1	300	37
0358917025	25 x 1"	50	90	1	300	53

Plasson Series 1 Wrench

10990



Product Code	Size	UB	UC	W
10990004P	20-32	1	300	72
10990002P	40-63	1	100	285

Chamfer Tool for PE Pipes

18960

Herramienta para biselar



Product Code	Size	UB	UC	W
189600063020P	20 - 63	-	64	202

Nut

10004

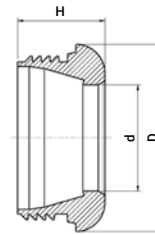

Product Code	Size d	D	H	UB	UC	W
100040020P	20	40	22	50	700	7
100040025P	25	45	22	50	500	8
100040032P	32	57	24	50	300	15
100040040P	40	68	33	—	400	29
100040050P	50	83	37	—	125	44
100040063P	63	100	43	—	100	60

NBR O-Ring

10002



Product Code	Pipe Size	E	e	UB	UC	W
100020020P	20	19	4	50	32000	1
100020025P	25	24	5	50	16000	2
100020032P	32	31	6	50	10000	4

EPDM O-Ring

10002D



Product Code	Pipe Size	E	e	UB	UC	W
10002D020P	20	19	4	50	32000	1
10002D025P	25	24	5	50	16000	2
10002D032P	32	31	6	50	10000	4

NBR Shaped Seal

100029



Product Code	Pipe Size	E	e	UB	UC	W
100029040P	40	38	10	50	4000	8
100029050P	50	48.6	10.5	50	2500	11
100029063P	63	60.6	11.2	50	2000	15

EPDM Shaped Seal

10002D



Product Code	Pipe Size	E	e	UB	UC	W
10002D940P	40	38	10	50	4000	8
10002D950P	50	48.6	10.5	50	2500	11
10002D963P	63	60.6	11.2	50	2000	15

Split Ring

10003

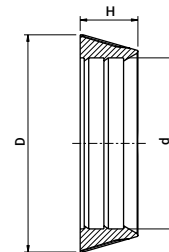

Product Code	Size d	D	H	UB	UC	W
100030020P	20	27	9	50	6000	2
100030025P	25	33	9	50	4500	3
100030032P	32	42	11	50	2000	4
100030040P	40	52	14	—	1600	14
100030050P	50	64	17	—	500	14
100030063P	63	81	21	—	500	27

Grip Ring

10008

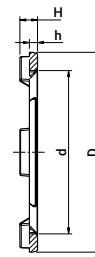

Product Code	Size d	D	H	h	UB	UC	W
100080020P	20	27	3.8	1.8	50	7000	1
100080025P	25	33	3.7	1.7	50	5500	1
100080032P	32	42	3.7	1.7	50	3000	1
100080040P	40	52	4.0	2.2	50	2500	2
100080050P	50	64	4.3	2.5	50	1000	3
100080063P	63	80	4.8	3.0	50	1000	6

PVC Pipe Adaptor Kit

1091Q

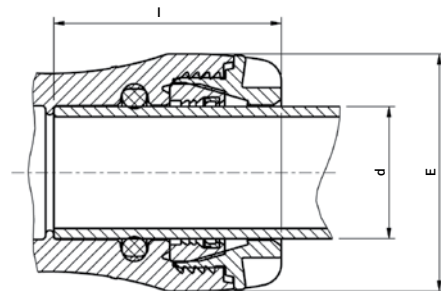

Product Code	Size d	E	I	UB	UC	W
1091Q0025	25	47	50	1	500	26
1091Q0032	32	58	55	1	400	31
1091Q0040	40	70	72	1	300	56
1091Q0063	63	103	95	1	100	134

Copper Pipe Adaptor Kit

10999

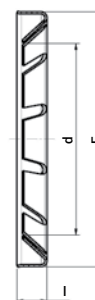
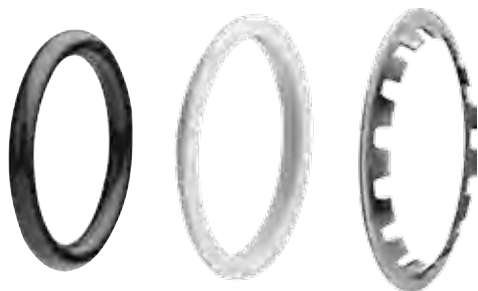

Product Code	Size d	E	I	UB	UC	W
10999915	15	41	45	—	—	2.4
10999922	22	47	48	—	—	2.6
10999928	28	58	53	—	—	3.0

Installation Instructions

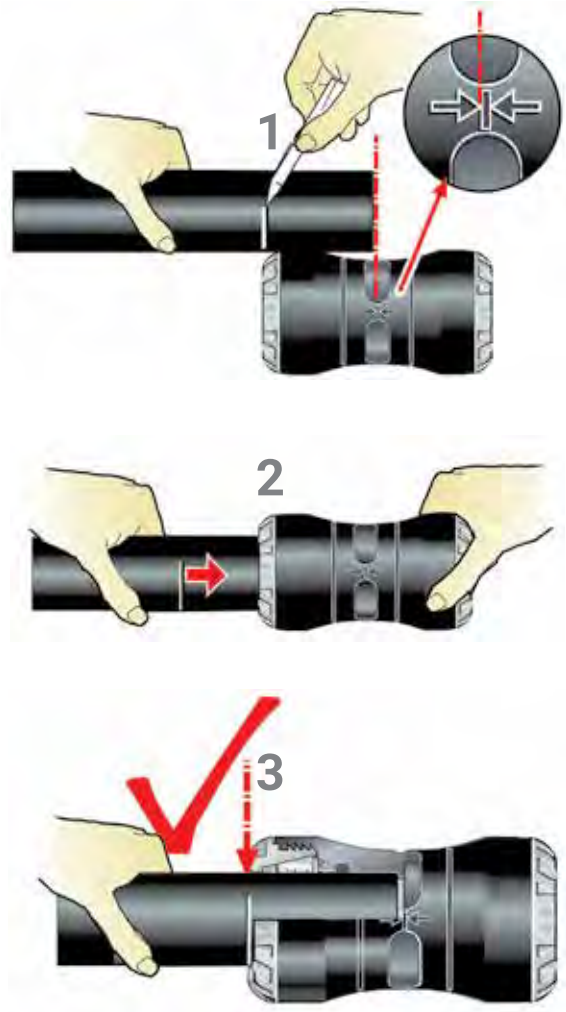

Disassembly

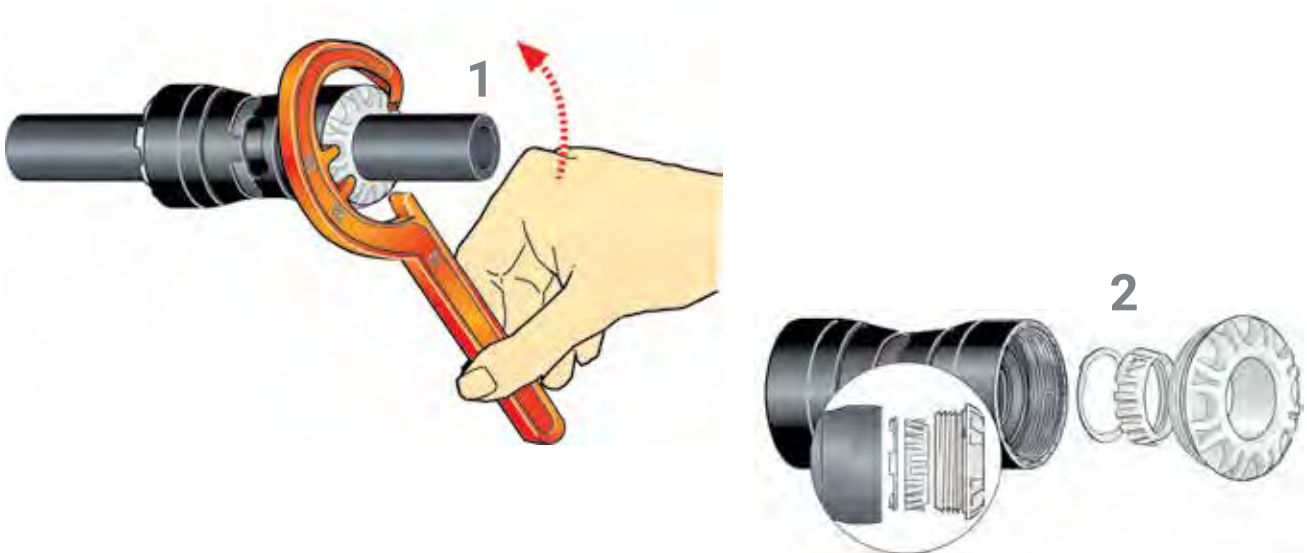

Assembly Instructions PVC Pipe Kit

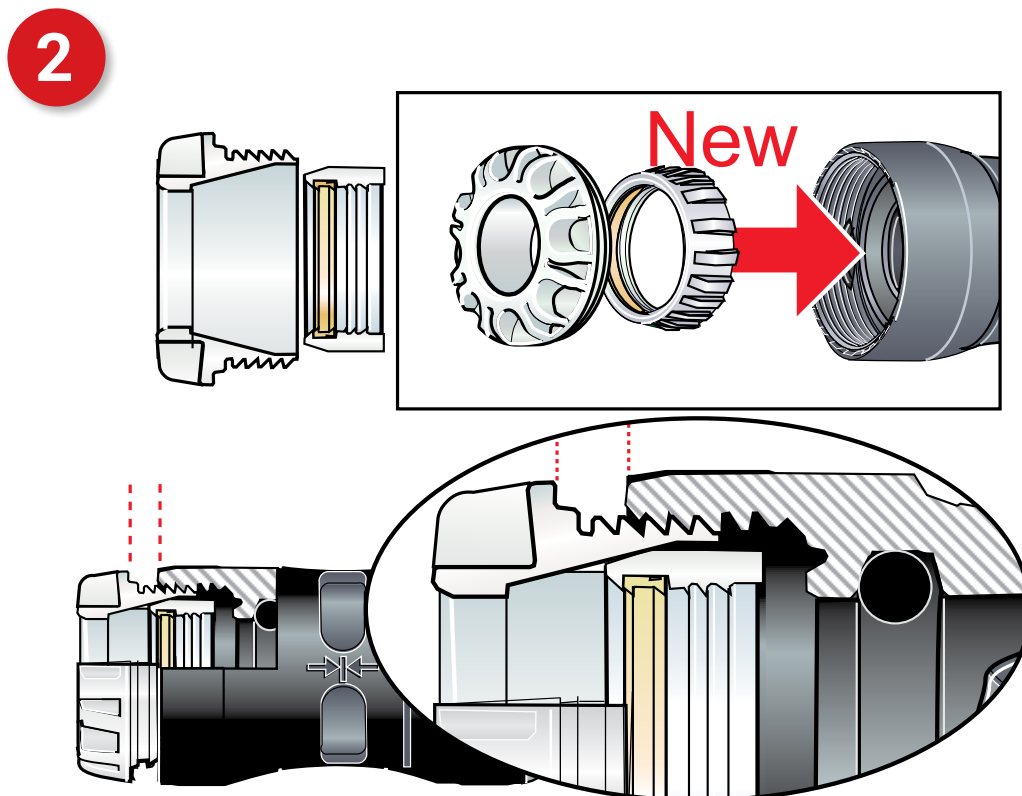
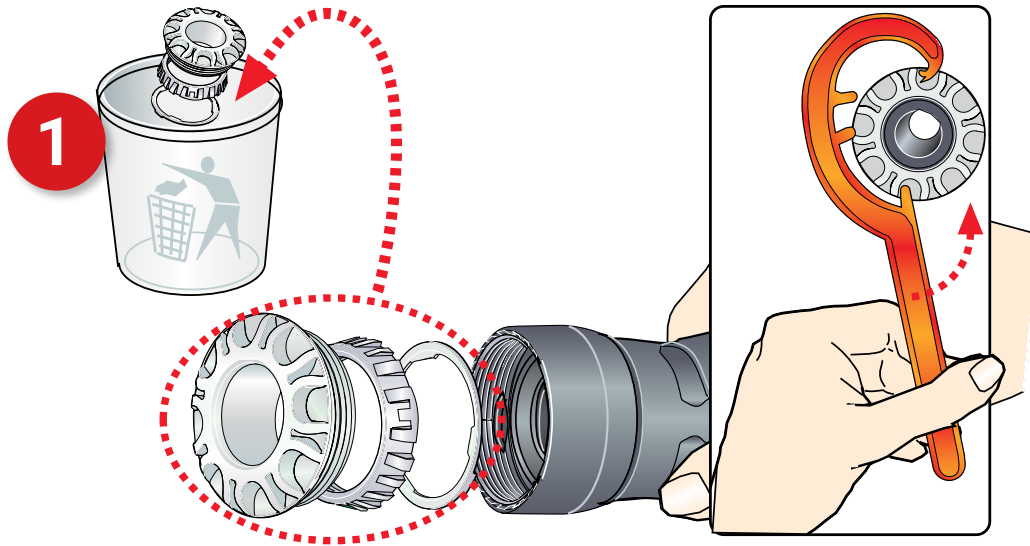

Connection Instructions PVC Pipe

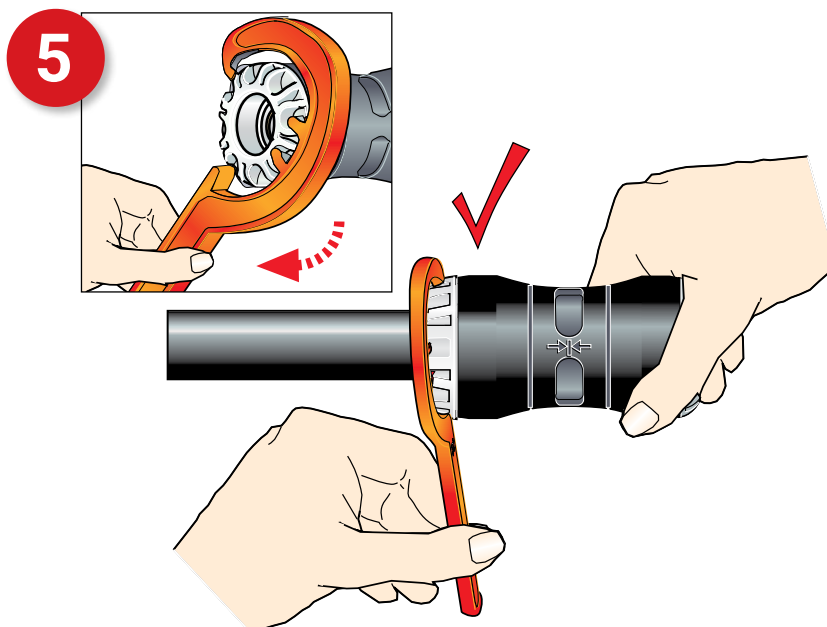
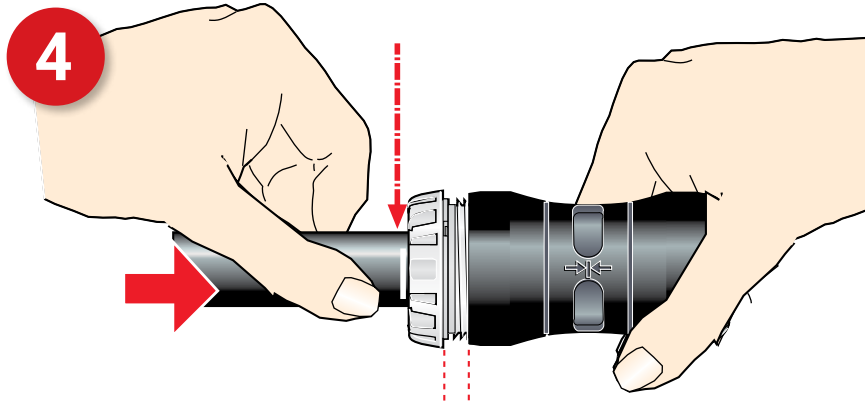
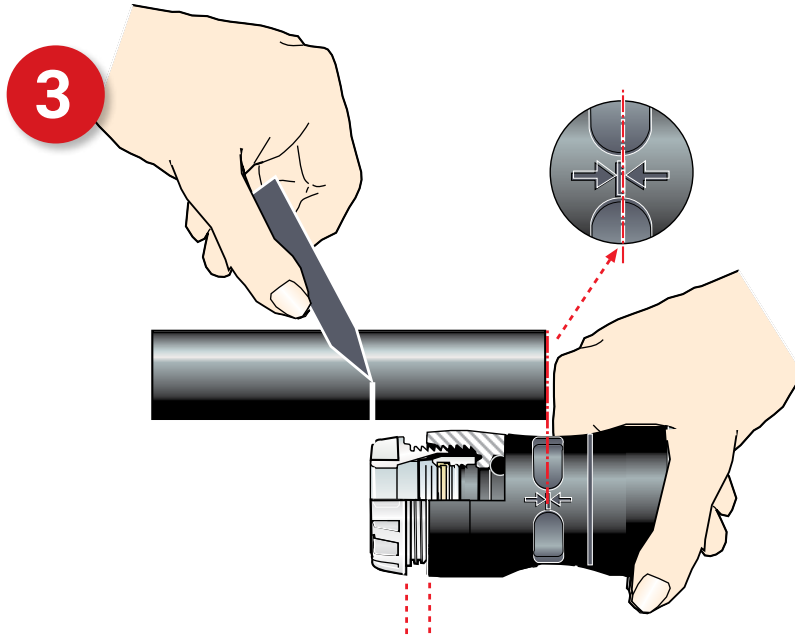





SILVER LINE FITTINGS



Silver Line

140100

Page 214 | Coupling
Enlace Recto



140200

Page 215 | Male Adaptor
Enlace Mixto Rosca Macho



140300

Page 216 | Female Adaptor
Enlace Mixto Rosca Hembra



141200

Page 216 | End Plug
Tapón Final



140400

Page 217 | 90° Tee
Te de 90°



141400

Page 217 | 90° Tee with Threaded
Female Offtake
Te de 90° Compresión
Rosca Hembra



148400

Page 218 | 90° Tee with Threaded
Male Offtake
Te de 90° Compresión
Rosca Macho



143400

Page 218 | 90° Reducing Tee with
Irrifit Outlet
Te de 90° Reductor



140500

Page 219 | 90° Elbow
Codo de 90°



141500

Page 219 | 90° Elbow with Threaded
Female Offtake
Codo de 90° Compresión
Rosca Hembra



148500

Page 220 | 90° Elbow with Threaded
Male Offtake
Codo de 90° Compresión
Rosca Macho



146500

Page 220 | Corner Elbow
Codo de Esquina



149300

Page 221 | Reducing Set
Juego Reductor

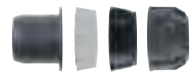

1401M0

Page 221 | Coupler Union Adaptor
Enlace Recto Con Racor



1498M0

Page 222 | Union Adaptor
Adaptador A Rosca Macho



078901

Page 222 | Threaded Male Adaptor
Adaptador Compresión
Rosca Macho



148940

Page 223

Nut Threaded Adaptor
Tuerca para Adaptador de
Compresión



140040

Page 223

Nut
Racor



140030

Page 224

Split Ring - Polyacetal
Casquillo de Apriete (acetal)



070020

Page 224

O-Ring
Junta Tórica/Seiil



140050

Page 225

Insert
Inserto de PP



Coupling

140100

Enlace Recto

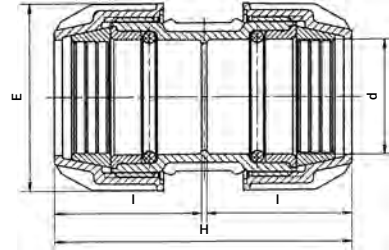

Product Code	Size d x d	E	H	I	UB	UC	W
140100016	16 x 16	39	105	50	10	400	48
140100020	20 x 20	42	90	44	10	500	35
140100025	25 x 25	50	98	48	10	300	56
140100032	32 x 32	61	114	56	10	160	100
140100040	40 x 40	73	127	62	5	100	150
140100050	50 x 50	92	146	74	5	60	245
140100063	63 x 63	106	167	82	2	40	400
840106075	75 x 75	132	281	139	—	16	1120
840106090	90 x 90	152	323	160	—	8	1690
840106110	110 x 110	181	393	195	—	5	1190

Male Adaptor

140200

Enlace Mixto Rosca Macho

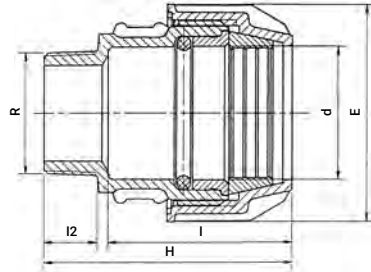

Product Code	Size d x R	E	H	I	I2	UB	UC	W
140200016003	16 x 3/8"	32	73	59	13	10	500	32
140200016005	16 x 1/2"	39	79	59	16	10	500	32
140200016007	16 x 3/4"	39	80	59	17	10	500	33
140200020005	20 x 1/2"	42	71	50	17	10	600	23
140200020007	20 x 3/4"	42	71	50	18	10	600	24
140200025005	25 x 1/2"	50	75	54	17	10	480	34
140200025007	25 x 3/4"	50	75	54	17	10	480	35
140200025010	25 x 1"	50	77	50	18	10	480	37
140200032007	32 x 3/4"	61	82	66	20	10	280	58
140200032010	32 x 1"	61	84	60	18	10	280	58
140200032013	32 x 1 1/4"	61	86	58	20	10	280	65
140200040010	40 x 1"	73	97	73	22	5	150	90
140200040013	40 x 1 1/4"	73	99	73	20	5	150	94
140200040015	40 x 1 1/2"	73	98	73	22	5	150	95
140200050015	50 x 1 1/2"	92	107	80	22	5	100	147
140200050020	50 x 2"	92	110	90	26	5	100	152
140200063020	63 x 2"	106	120	99	26	2	60	273
840206075020	75 x 2"	132	188	154	26	—	28	690
840206075025	75 x 2 1/2"	132	191	154	29	—	28	700
840206075030	75 x 3"	132	195	154	33	—	25	740
840206090020	90 x 2"	152	240	162	26	—	14	1030
840206090025	90 x 2 1/2"	152	233	160	29	—	14	1125
840206090030	90 x 3"	152	230	163	33	—	14	1116
840206090040	90 x 4"	152	223	181	38	—	12	1120
840206110020	110 x 2"	181	263	215	26	—	8	1895
840206110030	110 x 3"	181	258	215	33	—	8	1780
840206110040	110 x 4"	181	267	215	42	—	8	1916

Female Adaptor

140300

Enlace Mixto Rosca Hembra

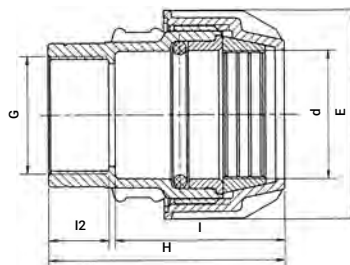

Product Code	Size d x G	E	H	I	I2	UB	UC	W
140300016005	16 x 1/2"	39	77	55	19	10	500	37
140300016007	16 x 3/4"	39	79	56	19	10	500	35
140300020005	20 x 1/2"	42	71	51	18	10	600	26
140300020007	20 x 3/4"	42	72	51	19	10	600	29
140300025007	25 x 3/4"	50	75	54	19	10	400	38
140300025010	25 x 1"	50	80	54	21	10	400	42
140300032007	32 x 3/4"	61	82	61	19	10	280	62
140300032010	32 x 1"	61	84	61	21	10	280	62
140300040010	40 x 1"	73	97	73	21	5	150	97
140300040013	40 x 1 1/4"	73	101	73	25	5	150	112
140300040015	40 x 1 1/2"	73	101	73	25	5	150	122
140300050015	50 x 1 1/2"	92	107	82	25	5	90	173
140300050020	50 x 2"	92	112	82	30	5	90	192
140300063020	63 x 2"	106	119	86	30	2	60	262
840306075020	75 x 2"	132	193	135	30	—	28	685
840306075025	75 x 2 1/2"	132	176	135	33	—	28	650
840306090020	90 x 2"	152	203	168	35	—	14	1102
840306090030	90 x 3"	152	223	184	39	—	14	1190
840306090040	90 x 4"	180	275	215	46	—	12	1410
840306110030	110 x 3"	152	244	184	43	—	8	1940
840306110040	110 x 4"	180	264	215	39	—	8	1947

End Plug

141200

Tapón Final

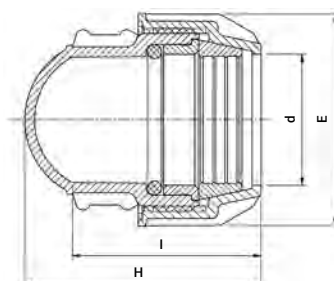

Product Code	Size d	E	H	I	UB	UC	W
141200025	25	50	59	48	10	520	30
141200032	32	61	67	54	10	330	53
141200040	40	73	80	67	10	180	32
141200050	50	92	93	71	5	100	54
141200063	63	105	112	80	2	60	86
841206075	75	132	171	161	—	28	740
841206090	90	152	207	198	—	16	1040
841206110	110	181	233	215	—	10	1920

90° Tee

140400

Te de 90°

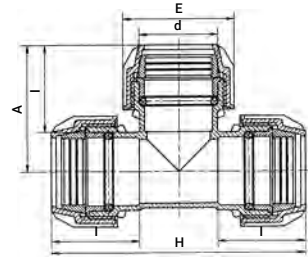

Product Code	Size d x d x d	E	H	I	A	UB	UC	W
140400016	16 x 16 x 16	39	126	50	63	10	200	79
140400020	20 x 20 x 20	42	113	43	57	10	250	77
140400025	25 x 25 x 25	50	124	47	60	10	170	85
140400032	32 x 32 x 32	61	150	56	75	5	100	148
140400040	40 x 40 x 40	73	173	62	86	5	60	244
140400050	50 x 50 x 50	92	207	74	104	2	32	394
140400063	63 x 63 x 63	106	239	82	119	2	20	643
840406075	75 x 75 x 75	132	359	136	180	—	8	1780
840406090	90 x 90 x 90	152	436	163	218	—	5	2860
840406110	110 x 110 x 110	181	588	196	294	—	2	5200

90° Tee with Threaded Female Offtake

141400

Te de 90° Compresión Rosca Hembra

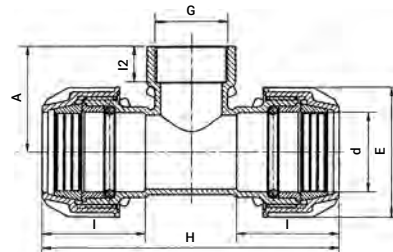

Product Code	Size d x G x d	E	H	I	I2	A	UB	UC	W
141400016005	16 x 1/2" x 16	39	124	51	19	30	10	240	66
141400016007	16 x 3/4" x 16	39	122	50	19	30	10	240	59
141400020005	20 x 1/2" x 20	42	113	44	18	43	10	320	48
141400020007	20 x 3/4" x 20	42	113	44	19	45	10	320	50
141400025005	25 x 1/2" x 25	50	123	48	18	45	10	200	71
141400025007	25 x 3/4" x 25	50	123	48	19	48	10	200	71
141400025010	25 x 1" x 25	50	123	48	21	50	10	200	75
141400032005	32 x 1/2" x 32	61	150	56	18	49	5	120	120
141400032007	32 x 3/4" x 32	61	150	56	19	52	5	120	118
141400032010	32 x 1" x 32	61	150	56	21	55	5	120	123
141400040010	40 x 1" x 40	73	173	62	21	63	5	70	188
141400040013	40 x 1 1/4" x 40	73	173	62	25	67	5	70	207
141400040015	40 x 1 1/2" x 40	73	173	62	25	68	5	60	204
141400050015	50 x 1 1/2" x 50	92	200	72	25	73	2	40	323
141400050020	50 x 2" x 50	92	200	72	30	79	2	40	348
141400063020	63 x 2" x 63	106	239	82	30	86	2	20	522
841406075020	75 x 2" x 75	132	366	135	30	110	—	8	1496
841406075025	75 x 2 1/2" x 75	132	338	132	35	85	—	8	1430
841406075030	75 x 3" x 75	132	366	135	36	110	—	8	1594
841406090030	90 x 3" x 90	152	413	162	41	116	—	7	2120
841406110040	110 x 4" x 110	181	511	198	52	140	—	4	4073

90° Tee with Threaded Male Offtake

148400

Te de 90° Compresión Rosca Macho

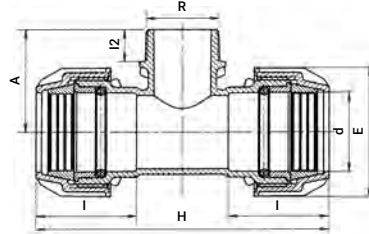

Product Code	Size d x R x d	E	H	I	I2	A	UB	UC	W
148400016007	16 x 1/2" x 16	39	113	44	18	45	10	300	35
148400020005	20 x 1/2" x 20	42	113	44	17	44	10	300	44
148400025005	25 x 1/2" x 25	50	124	48	17	45	10	220	63
148400025007	25 x 3/4" x 25	50	124	48	18	47	10	220	67
148400032007	32 x 3/4" x 32	61	150	56	18	49	5	120	112
148400032010	32 x 1" x 32	61	150	56	20	53	5	120	114
148400040010	40 x 1" x 40	73	173	62	20	65	5	70	182
148400040013	40 x 1 1/4" x 40	73	173	62	22	68	5	70	189
148400040015	40 x 1 1/2" x 40	73	173	62	22	69	5	70	192
148400050015	50 x 1 1/2" x 50	92	207	72	22	73	2	40	308
148400050020	50 x 2" x 50	92	207	72	26	77	2	40	316
148400063020	63 x 2" x 63	106	239	82	26	84	2	24	486

90° Reducing Tee with Irrifit Outlet

143400

Te de 90° Reductor

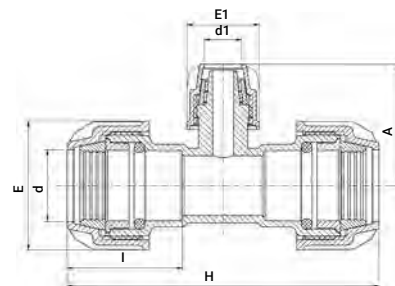

Product Code	Size d x d1 x d	E	H	I	E1	A	UB	UC	W
143400020016	20 x 16 x 20	42	113	44	34	48	10	300	56
143400025016	25 x 16 x 25	50	124	48	34	50	10	200	70
143400032016	32 x 16 x 32	61	150	56	34	54	5	100	117

90° Elbow

140500

Codo de 90°

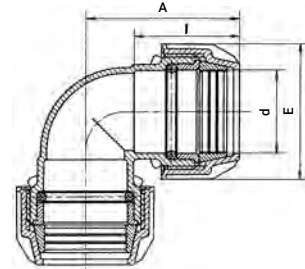

Product Code	Size d x d	E	A	I	UB	UC	W
140500016	16 x 16	39	64	51	10	350	50
140500020	20 x 20	42	57	43	10	440	38
140500025	25 x 25	50	62	47	10	250	59
140500032	32 x 32	61	75	56	10	150	102
140500040	40 x 40	73	86	62	5	90	164
140500050	50 x 50	92	104	74	5	50	276
140500063	63 x 63	106	119	82	2	32	442
840506075	75 x 75	132	179	135	—	12	1220
840506090	90 x 90	152	218	163	—	8	1940
840506110	110 x 110	181	294	196	—	3	3875

90° Elbow with Threaded Female Offtake

141500

Codo de 90° Compresión Rosca Hembra

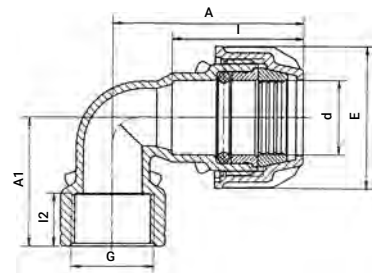

Product Code	Size d x G	E	I	I2	A	A1	UB	UC	W
141500016005	16 x 1/2"	39	50	19	66	39	10	500	39
141500020005	20 x 1/2"	42	44	17	56	42	10	600	29
141500020007	20 x 3/4"	42	44	18	56	42	10	500	30
141500025005	25 x 1/2"	50	48	18	68	45	10	380	44
141500025007	25 x 3/4"	50	48	18	68	45	10	380	43
141500025010	25 x 1"	50	48	21	68	50	10	340	48
141500032007	32 x 3/4"	61	56	18	75	47	10	220	64
141500032010	32 x 1"	61	56	21	75	60	10	200	70
141500032013	32 x 1 1/4"	61	56	25	75	66	10	160	91
141500040013	40 x 1 1/4"	73	62	25	86	70	5	120	130
141500040015	40 x 1 1/2"	73	62	25	86	70	5	110	141
141500050015	50 x 1 1/2"	92	74	25	102	79	5	70	203
141500050020	50 x 2"	92	74	30	102	79	5	70	226
141500063020	63 x 2"	106	82	30	115	86	2	44	327
841506075020	75 x 2"	131	136	30	191	100	—	20	770
841506075025	75 x 2 1/2"	132	136	36	195	105	—	17	860
841506075030	75 x 3"	132	136	36	195	105	—	17	980

90° Elbow with Threaded Male Offtake

148500

Codo de 90° Compresión Rosca Macho

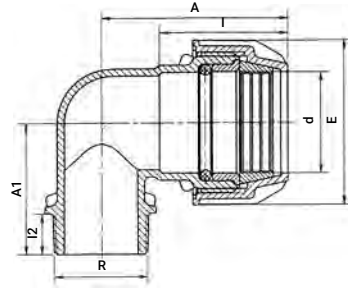

Product Code	Size d x R	E	I	I2	A	A1	UB	UC	W
148500016005	16 x 1/2"	39	58	17	70	44	10	600	28
148500016007	16 x 3/4"	39	58	18	70	45	10	600	28
148500020005	20 x 1/2"	42	43	17	57	44	10	600	26
148500020007	20 x 3/4"	42	43	18	57	45	10	600	29
148500025005	25 x 1/2"	50	47	17	62	45	10	400	36
148500025007	25 x 3/4"	50	47	18	62	47	10	400	39
148500025010	25 x 1"	50	47	19	62	49	10	400	39
148500032005	32 x 1/2"	61	56	17	75	49	10	240	65
148500032007	32 x 3/4"	61	56	18	75	49	10	240	62
148500032010	32 x 1"	61	56	20	75	53	10	240	66
148500040010	40 x 1"	73	62	20	86	65	5	120	103
148500040013	40 x 1 1/4"	73	62	22	86	68	5	120	114
148500040015	40 x 1 1/2"	73	62	22	86	69	5	120	121
148500050015	50 x 1 1/2"	92	74	22	104	73	5	70	176
148500050020	50 x 2"	92	74	26	104	77	5	70	192
148500063020	63 x 2"	106	82	26	119	84	2	48	248
848506075025	75 x 2 1/2"	132	136	30	206	105	—	18	876
848506075030	75 x 3"	132	136	33	206	110	—	18	911
848506090030	90 x 3"	152	164	34	232	110	—	12	1282
848506110040	110 x 4"	181	196	43	276	140	—	6	2259

Corner Elbow

146500

Codo de Esquina

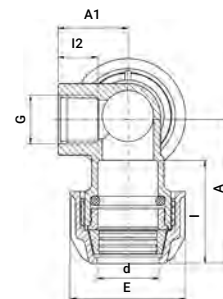

Product Code	Size d x G	E	I	I2	A	A1	UB	UC	W
146500020005	20 x 1/2"	42	39	17	58	30	10	350	50
146500025005	25 x 1/2"	50	44	17	62	30	10	250	70
146500025007	25 x 3/4"	50	44	17	62	30	10	250	60

Reducing Set

149300

Juego Reductor



Product Code	Size d x d1	E	I	UB	UC	W
149300025020	25 x 20	50	42	10	450	28
149300032020	32 x 20	61	48	10	400	33
149300032025	32 x 25	61	46	10	360	29
149300040032	40 x 32	73	55	10	250	48
149300050025	50 x 25	92	59	10	200	83
149300050032	50 x 32	92	64	10	200	79
149300050040	50 x 40	92	62	10	200	75
149300063025	63 x 25	106	63	10	100	150
149300063032	63 x 32	106	68	5	100	144
149300063040	63 x 40	106	74	5	100	136
149300063050	63 x 50	106	72	5	100	128

Coupler Union Adaptor

1401M0

Enlace Recto Con Racor



Product Code	Size d x d1	UB	UC	W
1401M0032007	32 x 3/4"	5	100	9
1401M0032010	32 x 1"	5	100	12
1401M0040010	40 x 1"	—	60	13
1401M0040015	40 x 1.1/2"	—	60	14
1401M0050015	50 x 1.1/2"	—	40	24
1401M0050020	50 x 2"	—	40	23
1401M0063015	63 x 1.1/2"	—	25	38
1401M0063020	63 x 2"	—	25	49

Union Adaptor

1498M0

Adaptador A Rosca Macho

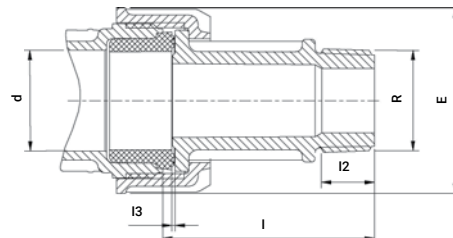

Product Code	Size d x R	E	I	I2	I3	UB	UC	W
1498M0032007	32 x 3/4"	39	68	18	1	1	180	77
1498M0032010	32 x 1"	39	69	20	1	1	180	55
1498M0040010	40 x 1"	42	70	20	1	1	130	142
1498M0040015	40 x 1.1/2"	42	71	22	1	1	130	89
1498M0050015	50 x 1.1/2"	50	73	24	1	1	80	126
1498M0050020	50 x 2"	50	79	27	1	1	80	133
1498M0063015	63 x 1.1/2"	61	75	22	1	1	60	—
1498M0063020	63 x 2"	61	77	26	1	1	60	306

Threaded Male Adaptor

078901

Adaptador Compresión Rosca Macho

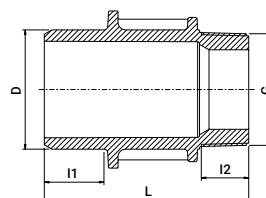

Product Code	Size d x G	L	I1	I2	UB	UC	W
078901025005P	25 x 1/2"	—	—	—	10	500	16.9
078901025007P	25 x 3/4"	—	—	—	10	500	19.4
078901032005P	32 x 1/2"	—	—	—	10	400	34.1
078901032007P	32 x 3/4"	—	—	—	10	400	35
078901032010P	32 x 1"	—	—	—	10	400	36.8
078901040010P	40 x 1"	—	—	—	10	220	53.7
078901040013P	40 x 1.1/4"	—	—	—	—	220	56.8
078901040015P	40 x 1.1/2"	—	—	—	10	220	61
078901050010P	50 x 1"	—	—	—	5	140	80.6
078901050013P	50 x 1.1/4"	—	—	—	—	140	83.9
078901050015P	50 x 1.1/2"	—	—	—	5	140	83.5
078901050020P	50 x 2"	—	—	—	5	140	91.1
078901063010P	63 x 1"	—	—	—	—	80	137.6
078901063013P	63 x 1.1/4"	—	—	—	—	—	139.5
078901063015P	63 x 1.1/2"	—	—	—	5	80	139.7
078901063020P	63 x 2"	—	—	—	5	80	145.5
078901063025P	63 x 2.1/2"	—	—	—	5	80	158.2

Nut for Threaded Adaptor

148940

Tuerca para Adaptador de Compresión



Product Code	Size d	UB	UC	W
148940032P	32	10	400	15
148940040P	40	10	200	23
148940050P	50	10	140	37
148940063P	63	–	–	61

Nut

140040

Racor



Product Code	Size d	UB	UC	W
140040016P	16	–	–	11
140040020P	20	10	1600	8.1
140040025P	25	10	1000	12
140040032P	32	10	500	20.6
140040040P	40	–	330	34
140040050P	50	–	180	68
140040063P	63	–	100	110

Split Ring - Polyacetal

140030

Casquillo de Apriete (acetal)



Product Code	Size d	UB	UC	W
070030016P	16	100	12000	1
140030020016P	20 x 16	100	6000	2
140030020P	20	100	12000	2
140030025P	25	100	7000	3
140030032P	32	—	4200	4
140030040P	40	—	2000	8
140030050P	50	—	1200	12
140030063P	63	—	600	24

O-Ring

070020

Junta Tórica/Seil



Product Code	Size d	E1	e	UB	UC	W
070020016	16	15	3	100	30000	1
070020020	20	19	3	100	32000	1
070020025	25	24	4	100	12000	1
070020032	32	31	5	100	10000	2
070020040	40	39	6	50	4000	5
070020050	50	49	7	50	2500	8
070020063	63	62	7	50	2000	10

Insert

140050

Inserto de PP



Product Code	Size d	UB	UC	W
070050016P	16	100	8700	1
140050020P	20	100	10000	1.3
140050025P	25	—	5500	2.4
140050032P	32	50	3000	4.4
140050040P	40	—	2000	5.6
140050050P	50	—	1000	8.9
140050063P	63	—	500	15.4

Technical Specifications

Installation Instructions For Fittings

16mm - 63mm

- Cut the pipe square, chamfer the end of the pipe
- Undo the nut to the last thread. Leave the nut on the fitting while inserting the pipe.
- Twist the pipe into the fitting* through the split ring and rubber seal to the pipe stop Tighten the nut firmly. Use a Plasson wrench (or similar tool) for final tightening of sizes 40 and above.
- The nut should be closed tightly, however there is no need for the nut to actually meet the body shoulder.

* Lubrication and chamfering of the pipe end will ease insertion of the pipe (use silicone lubricant).

Note

Before installation ensure that the end of the pipe to be inserted into the fitting is free of scratches and other imperfections and that both the pipe and the fitting itself are clean of sand, mud, stones etc.

Do not over tighten nut when closing. Never use wrenches or spanners with handle lengths longer than 46 cm - excessive torque during tightening can spread nut cone and result in pull outs.

If fittings are reused, ensure split ring is sharp and bites into pipe to avoid pull outs. Alternatively replace split ring.

We strongly recommend the use of PTFE tape in threaded connections.

Legend

UB	Units par bag
UC	Units per carton
W	Weight in grams

Technical Specifications

Plasson Silver Line - These fittings have been specially designed for joining polyethylene pipes used with a working pressure up to 10 bar. They are designed according to ISO standards and are available in sizes 16 - 63mm.

Features

- Perfectly watertight
- Extremely simple to use
- Easy and fast to reuse
- Designed with a captive O-ring
- Frost proof
- Suitable for outdoor use in direct sunlight
- Highly impact resistant

Materials

Body: Polypropylene, high-grade copolymer

Nut: Polypropylene, high-grade copolymer

Split Ring: Polyacetal (POM)

Seal: Nitrile rubber (EPDM)

Operating Temperatures

The fittings are not to be used with hot water, although they withstand the same temperature as the polyethylene pipe itself. The fittings and valves will withstand sub-zero temperatures.

Threads

All threads conform to ISO-7/1, BS 21 - 1973, DIN 2999, NEN 3258, AS 1722 Part 1 - 1975.

Especificaciones Técnicas

Installation Instructions Para accesorios de 16mm - 63mm

- Corte el tubo al tamaño requerido y realice el biselado al final del tubo
 - Retire el racor hasta su última rosca dejándolo en el accesorio durante el próximo paso.
 - Introduzca el tubo con un movimiento circular dentro del accesorio pasando el casquillo de apriete y el sello hasta llegar al tope interno del accesorio
 - Gire firmemente el racor en dirección del cuerpo del accesorio, utilizando la llave Plasson (o similar) en los tamaños 40mm y mayores.
 - Cierre el racor firmemente, aunque no es necesario cerrarlo hasta el tope.
- * A fin de facilitar la introducción es conveniente lubricar y biselar el tubo (con un lubricante que conforma las normas de aprobación de calidad del agua).

Nota

Antes de la instalación asegure que:
El extremo del tubo introducido no tenga imperfecciones o rayaduras. Tanto el tubo como el accesorio no tenga sobre los mismos arena, barro o piedras, etc. No cierre el racor con extremada fuerza, nunca use llaves con manijas más largas de 46 cm.

Un excesivo momento de torsión durante el cierre puede dañar el cono del racor y como resultado del mismo no permitir su propio funcionamiento. Si los accesorios son usados nuevamente después de su desarmado, constate que los dientes del casquillo de apriete permanecen afilados y se hincan en el tubo impidiendo el escape del tubo. Si no es así, cambie el casquillo de apriete.

Recomendamos utilizar cinta de PTFE para sellar todas las conexiones roscadas.

Legend

UB	Unidades por bolsa
UC	Unidades por cartón
W	Peso en gramos

Especificaciones Técnicas

Los accesorios de la Línea Silver de Plasson han sido diseñados para la unión de tuberías de polietileno de alta densidad usados con una presión de trabajo de hasta 10 bar. Están diseñados de acuerdo a las normas ISO y están disponibles en diámetros de 16 - 63mm.

Características

- Estanqueidad completa
- Fácil instalación
- Rápida reutilización
- Diseñada con una junta tórica cautiva
- Resistencia a bajas temperaturas
- Frost Proof
- Resistentes para instalación a la intemperie
- Alta resistencia a golpes o impactos

Materiales

Cuerpo: Polipropileno, block copolímero de alta calidad

Racor: Polipropileno, block copolímero de alta calidad

Casquillo de apriete: Polyacetal (POM)

Junta tórica: Nitrilo (EPDM)

Temperaturas de Trabajo

Los accesorios no son recomendados para usar con agua caliente, aunque soportan las mismas temperaturas que las propias tuberías de polietileno.

Sin embargo pueden resistir temperaturas inferiores a los cero grados centígrados.

Roscas

Todas las roscas responden a las normas ISO-7/1, BS 21, DIN 2999, NEN 3258, AS 1722 Part 1 - 1975.

GLOBAL PRESENCE - LOCAL COMMITMENT

 **PLASSON**[®]

www.plasson.com